

ARRI

ARRIFLEX 416

Instruction Manual

As of: Dezember 2006

ALL ARTWORK, PICTURES AND TEXTS ARE COVERED BY OUR COPYRIGHT.

THEY MUST NOT BE COPIED (E.G. ON CD-ROM, DISKS OR INTERNET-SITES) OR USED IN THEIR ENTIRE FORM OR IN EXCERPTS WITHOUT OUR PREVIOUS WRITTEN AGREEMENT.

IF YOU ARE DOWNLOADING PDF-FILES FROM OUR INTERNET HOMEPAGE FOR YOUR PERSONAL USE, MAKE SURE TO CHECK FOR UPDATED VERSIONS.

WE CANNOT TAKE ANY LIABILITY WHATSOEVER FOR DOWNLOADED FILES, AS TECHNICAL DATA ARE SUBJECT TO CHANGE WITHOUT NOTICE.

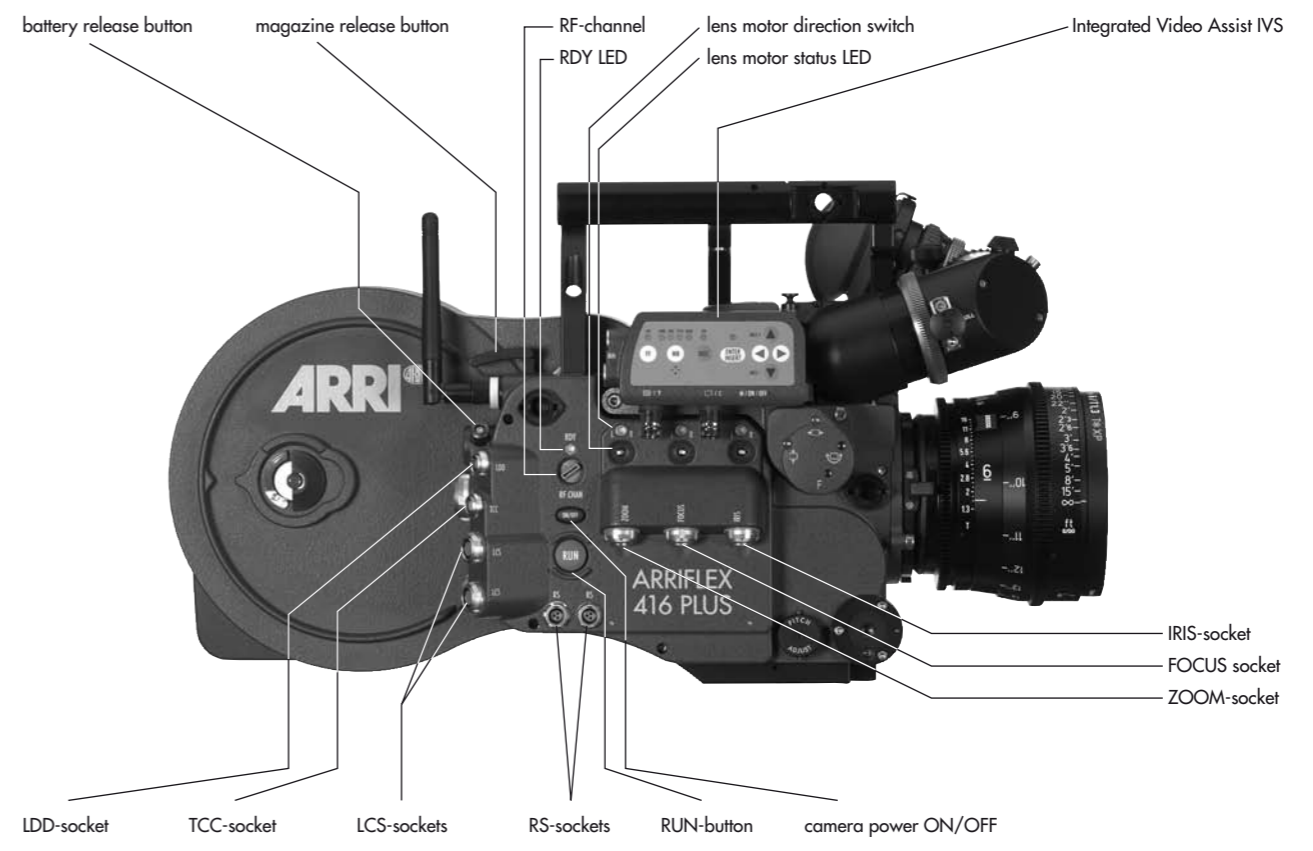
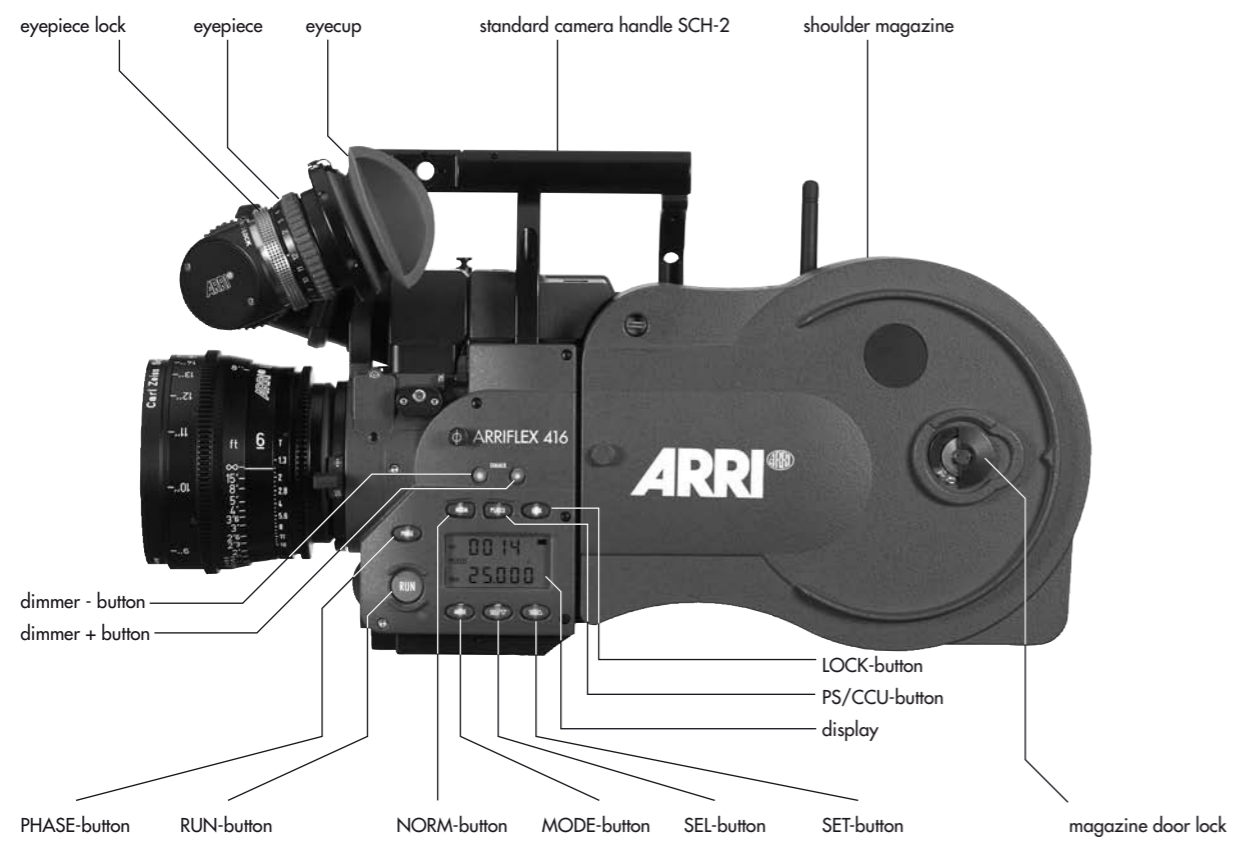
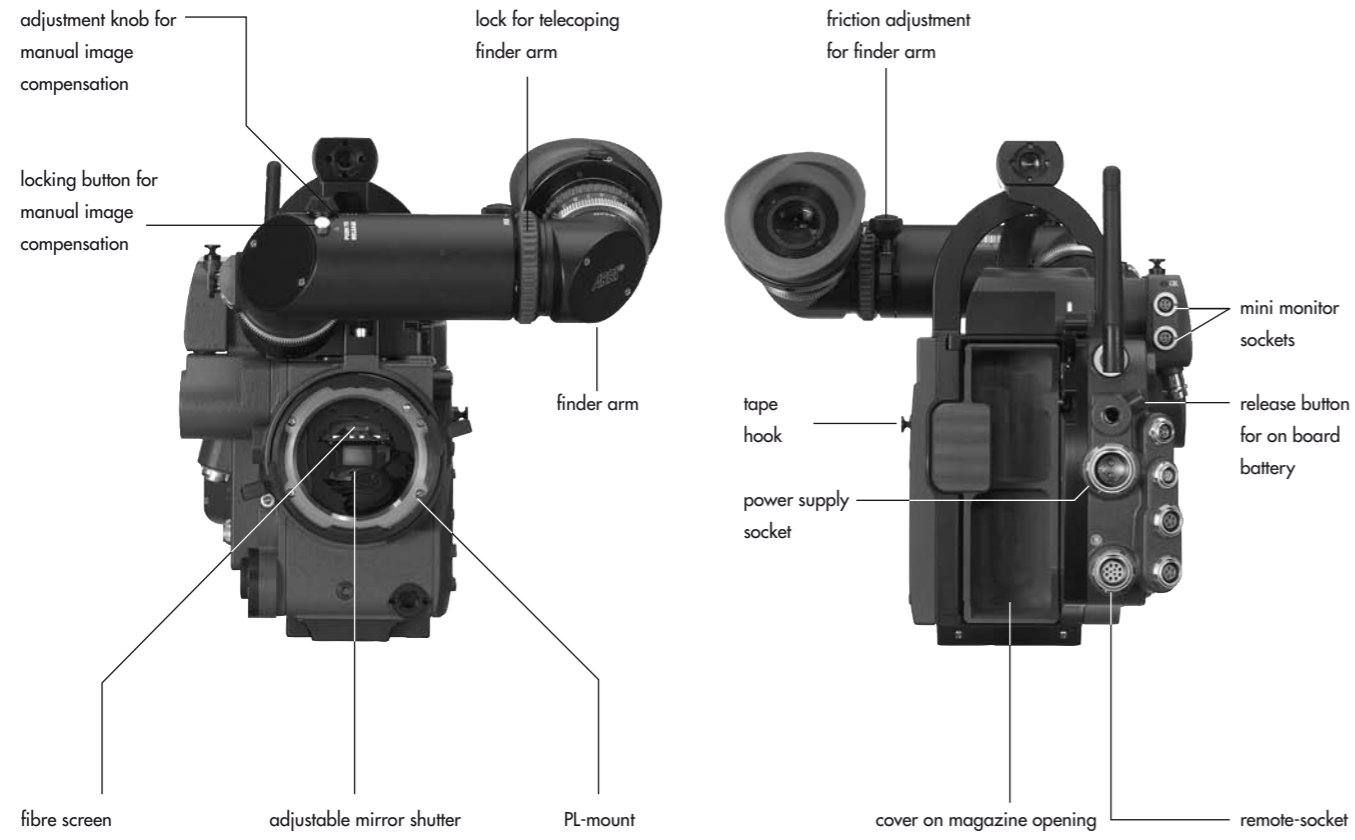

1. Contents

1. Contents	3	4.6 Grip System	22
2. Safety Instructions and Legal Disclaimer	7	416 Standard Camera Handle SCH-2	22
2.1 Safety Instructions	7	416 Riser	23
Warning signs	7	Low Mode Support Set LMS-2	24
General safety instructions	7	416 Lightweight Support LWS-5	26
Specific safety instructions	9	4.7 Operation from the Shoulder	27
2.2 Disclaimer	10		
3. General Description of the ARRIFLEX 416 ...	13		
4. Installation of the Camera	15	5. Power Supply	28
4.1 Packing and Transport	15	5.1 Battery NC 24/7 R	29
4.2 Tripod & Remote Heads	15	5.2 Charger NCL 24 R	29
4.3 Split Bridge Plates BP-10 & BP-11	16	5.3 Mains Units NG 12/24 R and NG 12/26 R	30
Attaching the Bridge Plate to the Camera	16	5.4 On-board Battery OBB-2	30
Removing the Split Bridge Plate		Mounting the OBB-2	31
from the Base Plate	18	Removing the OBB-2	31
Removing the Camera from the Tripod		Charging the OBB-2	32
for Hand-held Operation	18	5.5 Accessory Power Supply	33
4.4 Accessory Carrier	19	24 V Accessories	33
The 416 Shoulder Pad - SP-2	19	Overload	33
The 416 Left Rod Bracket – LRB-2	20		
4.5 Lens Support	21	6. Magazines	35
		6.1 Loading the 416 Magazine	35
		6.2 Checking the Loop Size	39
		6.3 Removing Exposed Film	40
		6.4 Transport and Storage	41

7. Camera Body	43
7.1 Mechanically Adjustable Mirror Shutter	43
Setting the Mirror Shutter Angle	43
Shutter Angle Measurement	44
Filming with HMI Light	45
7.2 Exchanging the Fibre Screen	46
7.4 Attaching the Magazine	47
7.5 Removing the Magazine	48
8. Optics	49
8.1 Lenses	49
Attaching Lenses	49
8.2 Viewfinder System	50
The Eyepiece	50
Adjusting the Viewfinder	51
9. Camera Operation	55
9.1 Main Camera Switch	55
9.2 Running and Stopping the Camera	55
Running the Camera	56
Stopping the Camera	56
Inching	57
9.3 Displaying and Setting Operational Parameters ...	57
Overview of Display Modes	58
Overview of Display Symbols	59
Film Counter	60
Frame Rates	62
Shifting phase	64
Displaying Power Supply Voltage (Mode 3)	64
Displaying On-board Battery information (Mode 3)	65
Setting the Low Battery warning level (Mode 3)	66
Displaying the Timecode Time and Frame Rate (Mode 4)	67
Turning Timecode Recording On and Off (Mode 4)	67
Displaying and Setting the Timecode User Bits (Mode 5)	68
Setting the brightness of the button illumination (Mode 6)	68
Switching the Beeper On and Off (Mode 6)	69
Setting the Volume of the Warning Signal (Mode 6)	69
Selecting a Preset ARRIGLOW Color (Mode 7)	70
Setting a User-Adjustable ARRIGLOW Color (Mode 7)	71

10. Video Assist System	73	10.4.8 System, LDS and Status Menu	136
10.1 General Description of the IVS	73	10.4.9 User Text Menu	144
New Features.....	73	10.4.10 Timecode Menu	150
Main Features	74	10.4.11 USER BITS Menu	156
10.2 Setup	76	10.4.12 Pull-Down Menu	160
10.2.1 Installation	76	10.4.13 VITC Line Menu	165
10.2.2 Cabling	78	10.4.14 White Line Menu	168
10.3 Standard Video Controls	85	11. Timecode	173
10.3.1 Switch On, Off and Check/Hide Menu ..	85	TC-Input	173
10.3.2 Mechanical Iris	86	Increased accuracy of the TC Generator	174
10.3.3 Alignment of the image position (X, Y and Rotation) and focus	87	TC Output	175
10.3.4 White Balance (WB)	88	Timecode and ESU-1	175
10.3.5 Gain Control	94	Using Timecode	176
10.3.6 Flicker free on/off	97	Turning on and off the TC Recording	176
10.3.7 Changing Format marking number	99	Indicating Timecode or User Bits	177
10.3.8 Storing a video image	101	Overview of the Display Indications used in Timecode Operation	178
10.3.9 Wrong Cable Warning LED	103		
10.4 Inserter Facilities	105		
10.4.1 Setting the On-Screen Displays	106		
10.4.2 Main Menu	107		
10.4.3 Load/Store Menu	108		
10.4.4 White Balance (WB), Manual Gain Control (MGC) and Bars Menu	112		
10.4.5 Video and Text Adjustment Menu	120		
10.4.6 Format Marking Menu	128		
10.4.7 Compare/Store Menu	133		

12. ARRIFLEX 416 Plus	185	13. Accessories	203
12.1 General Description	185	Accessory Mounting Points	203
12.2 Radio system	186	Work Light WL-3	204
12.3 Wireless Remote System	188	Heated Eyecup HE-4 & HE-5	204
Lens Motors	188	Remote "RUN" Switch RS-4	205
WMU-3, WBU-3, WFU-3 and CLM-2 Motors ..	190	External Synchronization Unit ESU-1	206
2 x WMU-3, WBU-3, WFU-3		Remote Control Unit RCU-1	207
and CLM-2 Motors	191	Wireless Remote Control WRC-1	208
ZMU-3, WMU-3, WBU-3, WFU-3			
and CLM-2 Motors	192	14. Maintenance	211
ZMU-3, WZB-3, WBU-3, WMU-3 and WFU-3		Camera	212
with CLM-2 Motors	193	Magazine	214
WHA-2, WFU-3, WZB-3, ZMU-3			
and CLM-2 Motors	194	15. Appendix	217
ZMU-3, WZB-3, WBU-3, WMU-3, LDD-FP,		Fuses	217
WEB-3, WFU-3 and CLM-2 Motors	195		
12.4 Camera Remote Control	196	16. Technical Data	223
WRC-1 via wireless remote control	197		
WRC-1 with WHA-2 via cable	198	17. Order Numbers	225
WRC-1 with WHA-1	199		
RCU-1	200	18. ARRI Service	227
12.5 Lens Data Display	201		
Compatibility	201	19. Index	229
Lens Data Archive	201		

2. Safety Instructions and Legal Disclaimer

2.1 Safety Instructions



Always follow these instructions to ensure against injury to yourself and damage to the system or other objects.



This safety information is in addition to the product specific operating instructions in general and must be strictly observed for safety reasons.

Warning signs



Possible risk of injury or damage to equipment.



This symbol indicates the risk of electric shock or fire danger that could result in injury or equipment damage.

General safety instructions



Read and understand all safety and operating instructions before you operate or install the system.



Retain all safety and operating instructions for future reference.



Heed all warnings on the system and in the safety and operating instructions before you operate or install the system. Follow all installation and operating instructions.



Do not use accessories or attachments that are not recommended by ARRI, as they may cause hazards and invalidate the warranty.



Do not attempt to repair any part of the system. Repairs must only be carried out by authorized ARRI Service Centres.



Do not remove any safety measures of the system.



Do not operate the system in high humidity areas or expose it to water or moisture.



Do not place the system on an unstable trolley, stand, tripod, bracket, or table. The system may fall, causing serious personal injury and damage to the system or other objects.



Operate the system using only the type of power source indicated in the manual. Unplug the power cable by gripping the power plug, not the cable.



Never insert objects of any kind into any part of the system through openings, as the objects may touch dangerous voltage points or short out parts. This could cause fire or electrical shock.



Unplug the system from the power outlet before opening any part of the system or before making any changes to the system, especially the attaching or removing of cables.



Do not use solvents to clean.



Clean optical surfaces only with a lens brush or a clean lens cloth! In case of solid dirt moisten a lens cloth with pure alcohol. Discard contaminated lens cloth after use. Do not use it to clean lens.



Do not loosen any screws which are painted over!

Specific safety instructions



Never run the camera without a lens or a protective cap in the lens mount receptacle!



Never operate the magazine release mechanism while the camera is running!



As the iris ring end-stops of the ARRIMACRO lenses move when the lens is focussed, the ARRIMACRO lenses must not be used with the ARRI Wireless Remote System (WRS) or the Lens Control System (LCS).



There is danger of injury with rotating drive gears on the lens barrel, or when switching the operating direction of the 416 PLUS, UMC-1 and UMC-3 motor drives!

Any violation of these safety instructions or the non-observance of personal care could cause serious injuries (including death) and damage to the system or other objects.

Note: Notes are used to indicate further information or information from other instruction manuals.

⇒ **photo** indicates objects, which are shown in the illustration.

Product Identification

When ordering parts or accessories, or if any questions should arise, please advise the model type and serial number of the product in question.

2.2 Disclaimer

Before using the products described in this manual be sure to read and understand all respective instructions. The ARRIFLEX 416 and 416 PLUS is only available for commercial customers. The customer grants by utilization, that the ARRIFLEX 416/PLUS or other components of the system are only deployed for commercial use. Otherwise the customer has the obligation to contact ARRI preceding the utilization.

While ARRI endeavours to enhance the quality, reliability and safety of their products, customers agree and acknowledge that the possibility of defects thereof cannot be eliminated entirely. To minimize risks of damage to property or injury (including death) to persons arising from defects in the products, customers must incorporate sufficient safety measures in their work with the system and have to heed the statuted canonic use.

No part of this document may be copied or reproduced in any form or by any means without prior written consent of ARRI. ARRI assumes no responsibility for any errors that may appear in this document. The information is subject to change without notice.

For product specification changes since this manual was published, refer to the latest publications of ARRI data sheets or data books, etc., for the most up-to-date specifications. Not all products and/or types are available in every country. Please check with an ARRI sales representative for availability and additional information.

Neither ARRI nor its subsidiaries assume any liability for infringement of patents, copyrights or other intellectual property rights of third parties by or arising from the use of ARRI products or any other liability arising from the use of such products. No license, express, implied or otherwise, is granted under any patents, copyrights or other intellectual property rights of ARRI or others.

ARRI or its subsidiaries expressly exclude any liability, warranty, demand or other obligation for any claim, representation, or cause, or action, or whatsoever, express or implied, whether in contract or tort, including negligence, or incorporated in terms and conditions, whether by statute, law or otherwise. In no event shall ARRI or its subsidiaries be liable for or have a remedy for recovery of any special, direct, indirect, incidental, or consequential damages, including but not limited to lost profits, lost savings, lost revenues or economic loss of any kind or for

any claim by third party, downtime, good-will, damage to or replacement of equipment or property, any costs or recovering of any material or goods associated with the assembly or use of our products, or any other damages or injury of persons and so on or under any other legal theory.

In the case one or all of the forgoing clauses are not allowed by applicable law, the fullest extent permissible clauses by applicable law are validated.

ARRI is a registered trademark of Arnold & Richter Cine Technik GmbH & Co Betriebs KG.

Note:

This product and the accessories recommended by the manufacturer fulfil the specifications of the EU-Guideline 89/336/EWG.

General Description

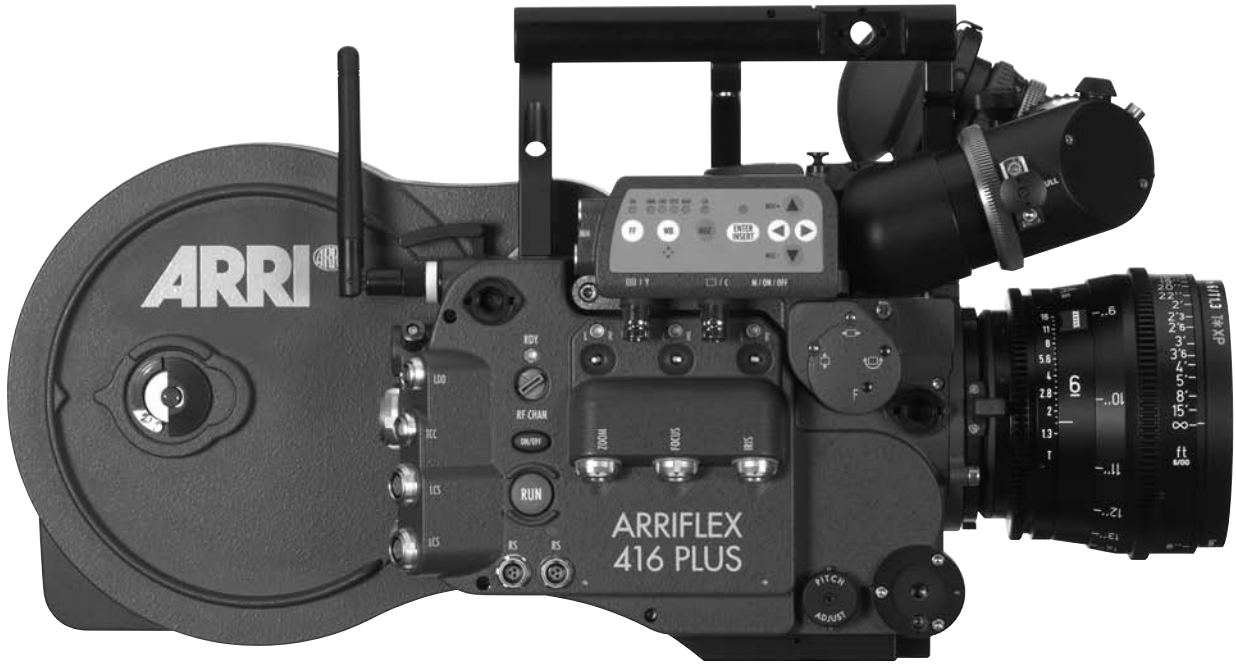

3. General Description of the ARRIFLEX 416

The ARRIFLEX 416 is a lightweight, modern Super 16 film camera with a 35-style viewfinder and a very low sound level. A completely new lightweight ergonomic design, integrated electronic accessories and compatibility with the same lenses and accessories used by its 35 mm siblings make the 416 a powerful, flexible and portable Super 16 camera.

There are two models: the ARRIFLEX 416 Plus and the 416. The 416 Plus has built-in lens motor drivers and radio modem for wireless lens and camera control. This eliminates add-on boxes and untidy cables.

- A sound level of less than 20dBA makes the 416 the quietest 16 mm camera available.
- The ARRIFLEX 416 is equipped with a low-maintenance, silent precision movement with single pull down claw and registration pin. Pull down is pitch-adjustable for quietest running.
- The viewfinder can be rotated in two axes and can be used on either side of the camera with full image orientation compensation. Its optics are bright and have a high contrast and high resolution. The viewfinder arm can be extended laterally for left eye operation.
- The high quality IVS video assist is integrated into the camera body.
- Speed ranges from 1 – 75 fps, forward only.
- The mirror shutter is manually adjustable to 180°, 172.8°, 150°, 144°, 135°, 90° and 45°.
- The 416's low profile design is substantially smaller and lighter than its predecessors.

A comprehensive range of optical, mechanical and electronic accessories further expands the operational possibilities of the camera.



4. Installation of the Camera

4.1 Packing and Transport



In order to prevent damage to the mirror shutter, a protective cap must be in the lens mount receptacle at all times.



*When the ARRIFLEX 416 is transported or stored without a magazine, the magazine opening cover ⇒ **photo** should be in place.*



*Loaded or empty magazines should only be transported or stored with the loop protector ⇒ **photo** attached to avoid damage to the film stock and the magazine throat assembly.*

4.2 Tripod & Remote Heads

The following tripod heads are suitable for use with the ARRIFLEX 416:

- ARRIHEAD
- ARRIHEAD 2
- ARRIHEAD 2 with integrated encoders
- ARRI fluid heads
- Sachtler Studio 7, 150 H
- Mitchell head
- OConnor 1030/2060/2575
- Moy head
- Ronford Mini 7/F7/2003/2015/Atlas 30/Atlas
- A&C Pee Pod 500, 1000 & 1600/Power Pod 2000 & Classic
- Hot Head
- Cam-Remote head
- Worall head



In applications where the camera mount is subject to high forces (e.g. helicopter mounts) the camera must be additionally secured with retaining cords. All fastening screws must be tightened firmly with an appropriate screwdriver (not with the commonly used coin!).

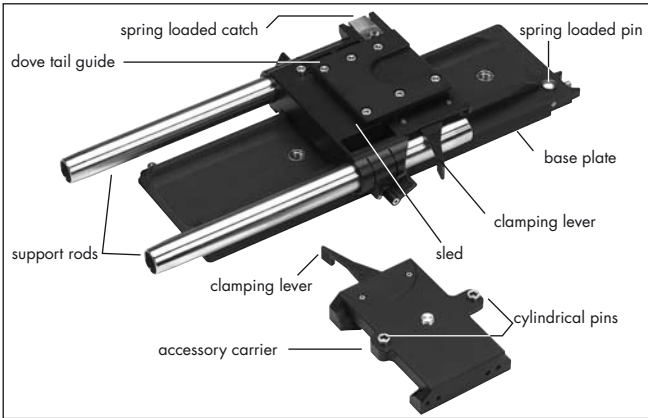
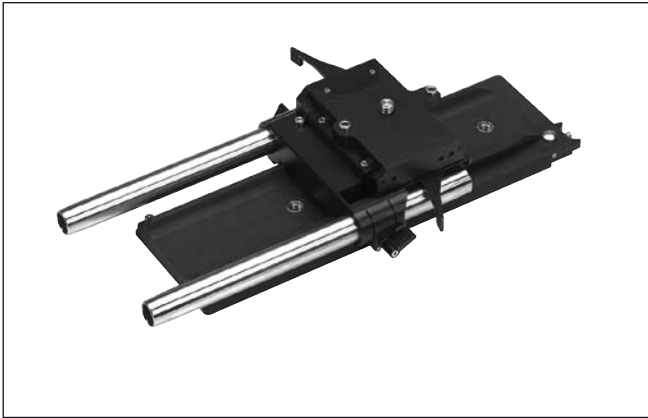

4.3 Split Bridge Plates BP-10 & BP-11

The Split Bridge Plates facilitate balancing of the camera on the tripod and elevate the 416 to proper height for the mounting of accessories. They separate into two pieces to allow you to quickly change between tripod and hand-held operation. The BP-10 ⇒ **photo** is designed for 19 mm support rods, the BP-11 for 15 mm support rods. The bridge plates consist of the Accessory Carrier, the Sled, the Base Plate and a pair of 240 mm long Support Rods

19 mm Support rods with lengths of 165 mm, 185 mm, 340 mm and 440 mm or 15 mm diameter support rods with lengths of 340 mm and 440 mm are available separately as options.

Attaching the Bridge Plate to the Camera

- Separate the Accessory Carrier from the Sled ⇒ **photo**.
- Engage the two cylindrical pins on the Accessory Carrier with the corresponding holes in the camera base then fasten it ⇒ **photo** with the slotted screw to the 3/8-16 threaded hole in the camera base. The clamping lever of the Accessory Carrier will be on the camera right side.
- Screw the Wedge Plate for Base Plate onto the Base Plate of the tripod and lock onto the tripod head.

- Slide the Sled into the dovetail-guide of the Base Plate until the spring-loaded stop pin ⇒ **photo** snaps back audibly. The Sled's position can then be fixed with the clamping lever.
- Fit the camera onto the short dovetail-guide on the Sled. Slide it forward until the spring-loaded catch ⇒ **photo** locks it in place.
- Tighten the clamping lever of the Accessory Carrier ⇒ **photo**.
- Slide the support rods into the guides and clamp.
- Equip the camera with the required accessories to determine the centre of gravity. Loosen the sled clamping lever, and by sliding the camera on the base plate find the optimum balance position. Then retighten the clamping lever.



The accessory carrier has the same dovetail as the bridge plate so it can be mounted to the base plate.

If the Lightweight Support is used and accessories are mounted to the Lightweight Support rods these accessories will collide with the base plate. In this configuration the accessory carrier can not be mounted to the base plate.





Removing the Split Bridge Plate from the Base Plate

- Before removing the camera, make sure that all cables are disconnected and that the eyepiece levelling rod is detached.
- For fast removal of the bridge plate from the base plate, loosen the sled clamping lever ⇒ **photo**, push in the stop pin ⇒ **photo** and then pull the camera with the Sled ⇒ **photo** from the base plate.

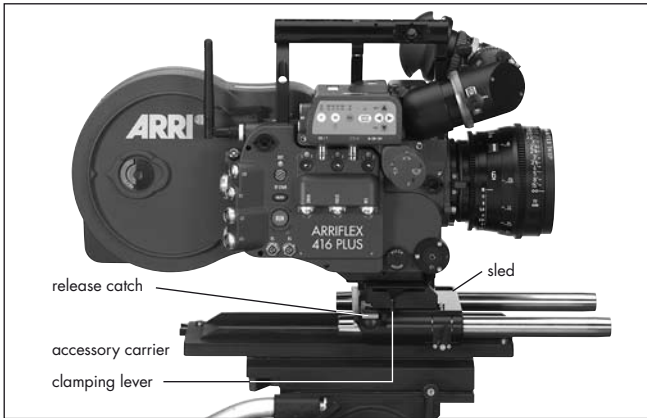

Removing the Camera from the Tripod for Hand-held Operation

- Before removing the camera, make sure that all cables are disconnected and that the eyepiece levelling rod is detached.
- For fast removal of the camera from the tripod for hand-held operation, loosen the accessory carrier clamping lever ⇒ **photo**, push in the release catch ⇒ **photo** and then pull the camera with the Accessory Carrier ⇒ **photo** away from the Sled.

4.4 Accessory Carrier

The Accessory Carrier is a part of the BP-10 & BP-11 Split Bridge Plates. It must be fitted to the camera to work with a split bridge plate but, as its name suggests, it is also needed for mounting the following accessories:

The 416 Shoulder Pad - SP-2

The SP-2 shoulder pad ⇒ **photo** is a comfortable sculpted pad for hand-held operation. It hinges at its front edge to allow it to be pushed down to facilitate the mounting and removal of magazines.

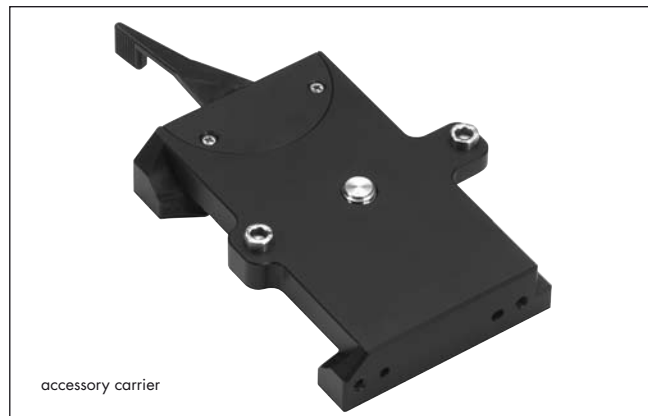

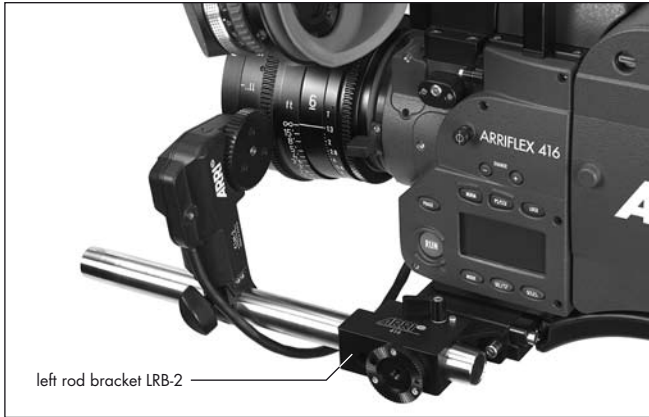

The 416 Left Rod Bracket – LRB-2

⇒ **photo** attaches to the left side of the Accessory Carrier to allow the mounting of single 19 mm support rod. It is also fitted with an Accessory Rosette.

4.5 Lens Support

Heavy or long lenses require support to avoid overstressing the camera's lens mount. Supporting a lens is achieved by using either the Lens Support LS-9 (snapped onto 19 mm support rods) ⇒ **photo** or the Lens Support LS-10 (pushed onto 15 mm support rods) in conjunction with a lens support ring ⇒ **photo** attached to the lens in use. They meet and screw together at a standard height.

- Mount the LS-9 lens support onto the support rods from above and let it click into place by applying slight pressure or push the LS-10 onto the support rods from the front.
- Fit the appropriate support ring ⇒ **photo** loosely onto the lens. Do not tighten.
- Then slide the lens into the lens mount receptacle and lock. It is essential that you take the weight of the lens until the Lens Support is under the support column of the lens support ring.
- Connect the support ring to the lens support and tighten the knurled screw ⇒ **photo** as well as the clamping lever ⇒ **photo**.
- Complete the process by tightening the clamp screw ⇒ **photo** on the support ring.

Note: Mounting the support ring on the relevant lens is usually carried out only once. The support ring can then remain in position on the lens.

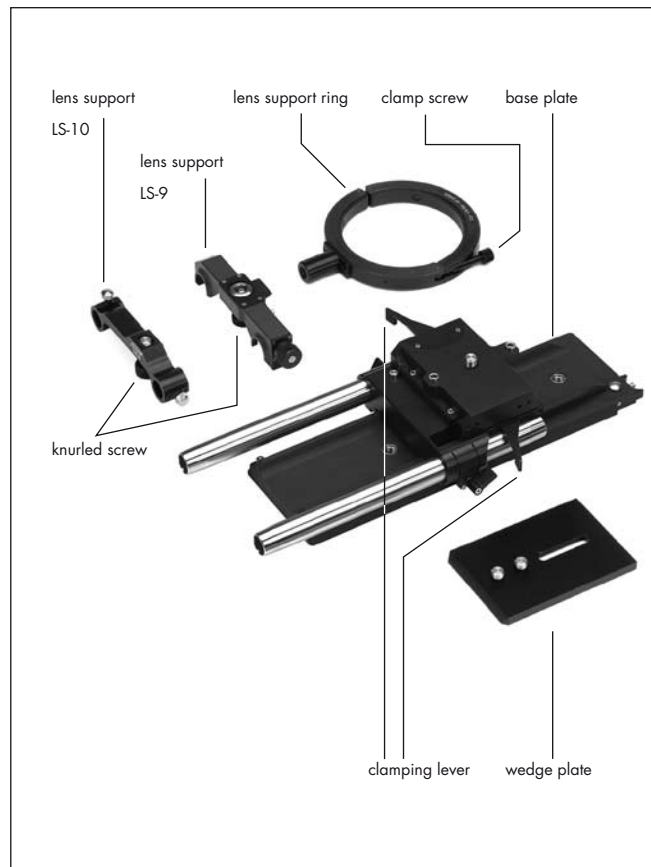

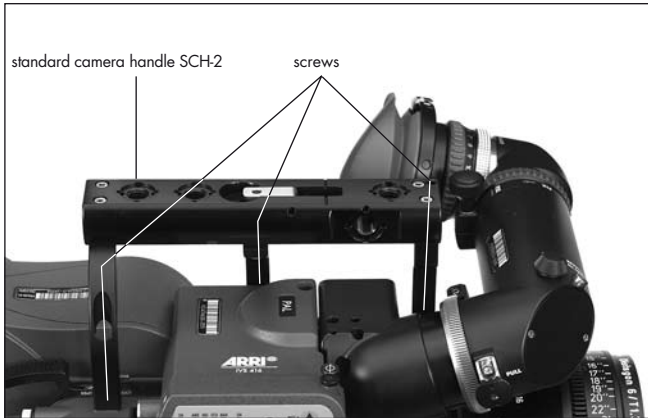

4.6 Grip System

The multipurpose grip system on the ARRIFLEX 416 guarantees high stability through its fixed connection to the camera body and provides numerous possibilities for attaching accessories. 3/8-16 inner threads allow attachment in various positions.

416 Standard Camera Handle SCH-2

The 416 Standard Camera Handle is a dual post handle. A third post can be added for extra stability when mounting the camera in an under-slung fashion. It is mounted on the camera using 2 (or 3) hexagonal screws ⇒ **photo**.

The 416 Standard Camera Handle includes a flip-out tape hook that can be folded away to leave a flat top surface to allow the camera to be under-slung and comfortably carried.

Various accessories can be attached using the 3/8-16 holes.

The 416 Standard Camera Handle can be extended with the Handle Extension Block HEB-1 ⇒ **photo**. The Handle Extension Block can be mounted to any of the 3/8-16 holes by first placing the 2 pins ⇒ **photo** into the corresponding pin holes on the handle and then fastening the extension block screw ⇒ **photo** inside the extension block by using a long 5mm Allen key. Note that the viewfinder cannot be swung over to the camera right side when the Handle Extension Block is attached to the front of the 416 Standard Camera Handle.

Note: The 416 Standard Camera Handle is positioned in the centre of gravity for a typical configuration.

416 Riser

A flat base with diverse attachment points for use when attaching the 416 to a Steadicam plate or other flat surface. Useful when working with Lightweight Support LWS-5, in order to have LWS-5 clear the mounting surface. Useful since 416 bottom threads are not compatible with some Steadicam plates. Also useful in situations requiring additional mounting security.

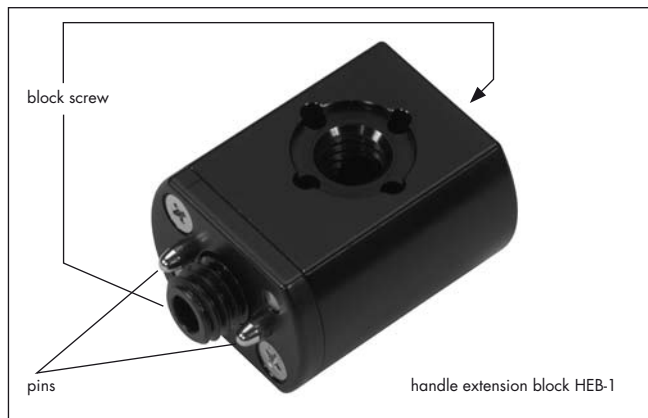

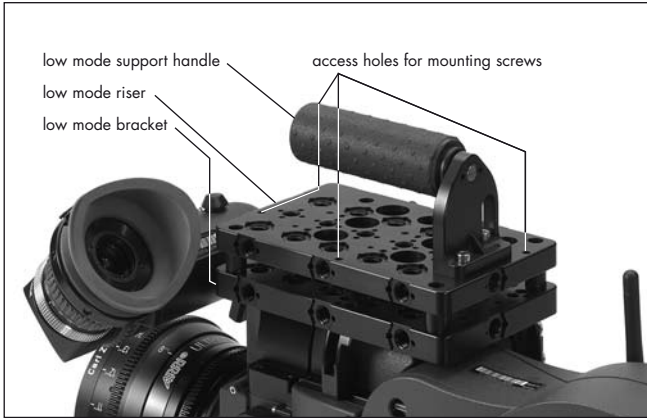

Low Mode Support Set LMS-2

The Low Mode Support Set LMS-2 ⇒ **photo** is a sturdy triple post camera handle with integrated Steadicam low mode plate that attaches to the 416 camera body. It consists of the Low Mode Bracket ⇒ **photo**, the Low Mode Support Handle ⇒ **photo** and Low Mode Riser ⇒ **photo**. The Low Mode Bracket is mounted with 3 hexagonal screws ⇒ **photo** to the 416 camera body.

The Low-Mode Handle can be attached on both the basic Low-Mode Bracket and the Low-Mode Riser. There are three mounting positions on the plates, one at the rear of the plate

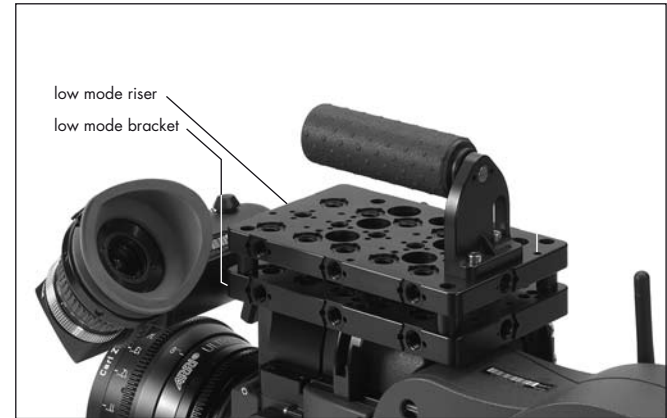
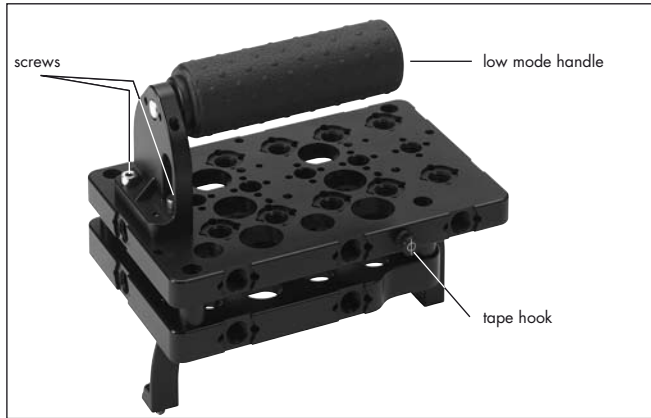

⇒ **photo**, one position approximately 50 mm (2") forwards and a third approximately 100 mm (4") forwards. The handle can be mounted in any of the positions facing forwards or backwards; in this way, the grip balance can be adapted to best fit the lens in use.

The Low-Mode Bracket ⇒ **photo** alone offers the lowest profile and smallest plate-to-lens distance, optimal for Steadicam applications. It can be attached with the viewfinder on the camera; however, since the Low-Mode Bracket remains under the level of the viewfinder itself, removal of the viewfinder will be necessary in applications requiring the attachment of a longer plate onto the Low-Mode Bracket.

With the Low-Mode Riser fitted, the plate to lens distance is increased so that a longer plate attached to the Riser will not collide with the viewfinder. This is especially useful in the situation where rapid switching between operation in low-mode and operation with viewfinder is necessary.

A tape hook is located camera right on the Low-Mode Riser, and both the Low-Mode Bracket and Low-Mode Riser offer diverse attachment points for additional accessories.

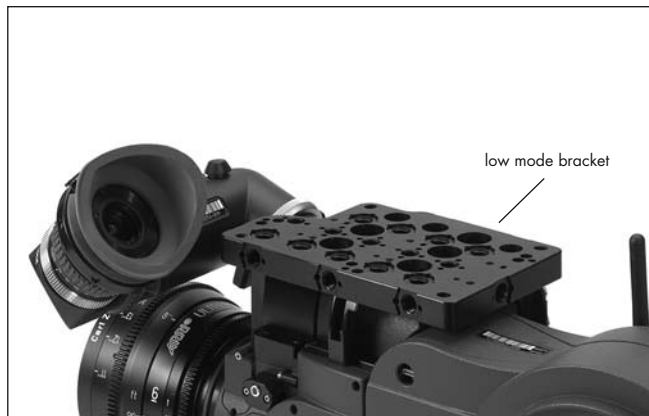

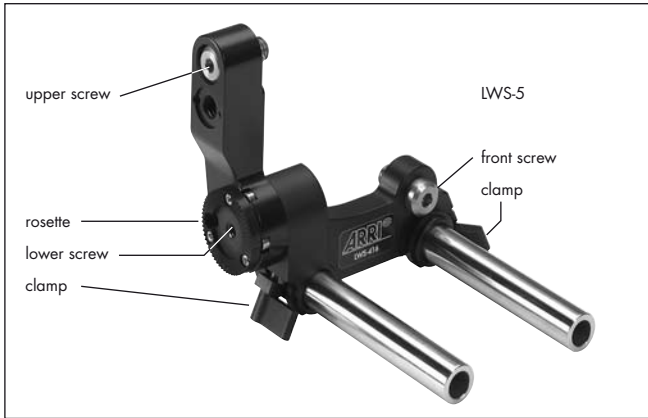

416 Lightweight Support LWS-5

The 416 Lightweight Support LWS-5 is a sturdy, three point bracket for mounting 15 mm lightweight support rods. The LWS-5 is fitted with an Accessory Rosette to replace the camera's rosette which is covered when the LWS-5 is fitted ⇒ **photo**.

- Fit the LWS-5 to the camera by first engaging the two guide pins of the upper 3/8-16 screw on the camera right side ⇒ **photo**. This will position the LWS-5 so that the 3/8-16 screw on the front of the bracket lines up with the threaded hole in the camera. Engage this screw by a few threads but leave it loose ⇒ **photo**.
- Tighten the two screws on the camera right side – the lower one is accessed through a hole in the Accessory Rosette teeth ⇒ **photo**.
- Tighten the front screw.
- Slide the support rods into the guides and clamp.

Note: Due to the camera's small dimensions and because the distance from the lens to the support rods is fixed, the rod clamps of the LWS-5 project below the camera base. To mount the camera with the LWS-5 fitted on a support system such as the Steadicam, it is necessary to fit the 416 Riser. This presents a flat base, clear of the support rods, with selection of threaded holes.

4.7 Operation from the Shoulder

- Fit the Accessory Carrier to the camera base.
- Attach the Shoulder Pad to the rear of the Accessory Carrier ⇒ **photo**.
- Position the handgrip on the rosette and fasten with the fastening screw ⇒ **photo**.
- Plug the cable for starting and stopping the camera into the RS socket.

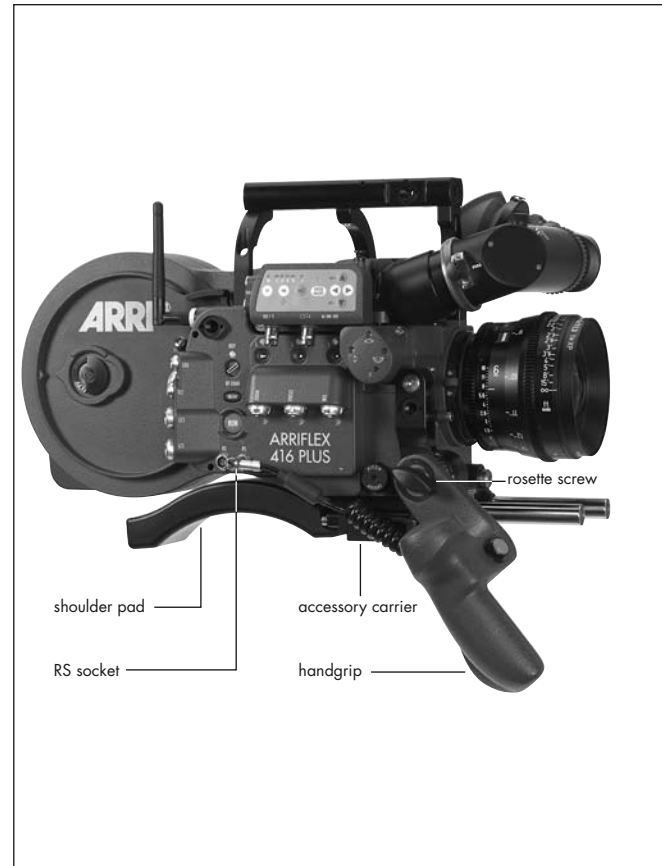

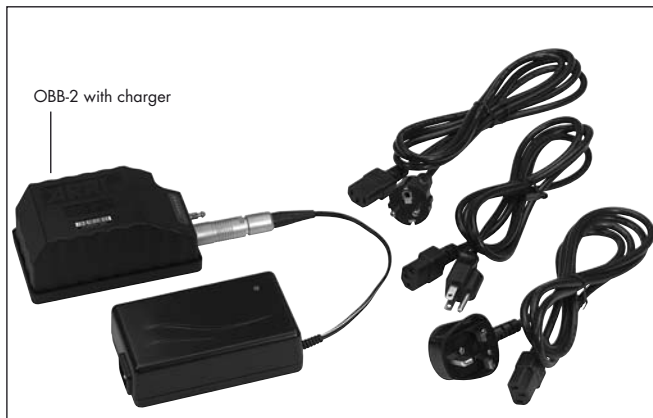

5. Power Supply

The acceptable voltage range to power the camera is from 20.6 to 35 V DC. The power supply cable is attached to the power supply socket on the camera. Available are:

- the battery NC 24/7 R with charger NCL 24 R
 - the mains unit NG 12/24 R.
 - the mains unit NG 12/26 R ⇒ **photo**.
 - the on-board battery OBB-2 with charger ⇒ **photo**.
- First switch on the mains unit (if used).
 - Connect the camera to the mains unit or to the battery.
 - Switch on the main switch of the camera.



*Do not open the batteries!
Charge batteries only with the proper ARRI
chargers!*



Do not bypass the fuse or temperature switch!



Do not heat NC-batteries!



Do not short-circuit NC-batteries!

5.1 Battery NC 24/7 R

The battery NC 24/7 R has a capacity of 7 ampere-hours.

- Ensure that the main switch on the camera is off.
- Plug the battery cable KC-20-S or the spiral battery cable KC-29-S into the power supply socket on the camera and into the battery socket.

Note: If the battery voltage is too low, the “bat” symbol will show in the camera display.

5.2 Charger NCL 24 R

Charge the NC 24/7 R battery with this charger.

- First check whether the correct mains voltage is set on the charger.
- Connect the charger to the mains supply.
- Plug the charger cable into the battery socket.
- Press the start button.

Indication of the LEDs

LED	Indication
yellow	discharging (1A)
red	charging
green	charger connected to the mains

5.3 Mains Units NG 12/24 R and NG 12/26 R

Use of a mains unit is recommended for filming in the studio and when using electronic accessories with high power consumption.

- First check that the correct mains voltage is set on the mains unit.
- Ensure that the camera power is turned off.
- Set the voltage switch on the mains unit to 24/26 V.
- Plug the battery cable KC-20-S or the coiled battery cable KC-29-S into the power supply socket on the camera and into the 24/26 V socket on the mains unit.

Note: The NG 12/24 R was the original design that provided 12 & 24 volts out – this was superseded by the NG 12/26 R which outputs 12 & 26 volts. The NG 12/24 R can easily be upgraded to NG 12/26 R specification at an ARRI Service Centre.

5.4 On-board Battery OBB-2

The OBB-2 On-Board Battery attaches directly to the camera body by means of a quick change mechanism that can be easily operated with one hand. The OBB-2 incorporates a built-in power meter to indicate the state of charge, while an extra contact in the power connector communicates this and other information to the camera. When an OBB-2 is connected, display Mode 3 offers the choice of showing battery voltage (as normal) or battery capacity (in percent) or an estimation of how many more magazines the remaining charge can run. The OBB-2 is an intelligent 29.6 volt Lithium-Ion battery with a capacity of 80 Watt/hours. A fully charged OBB-2 will typically run seven magazines and last about four hours in Standby. Although the 416 power connector has an additional contact it remains compatible with standard ARRI 24 volt power cables.



The OBB-2 is for use with ARRIFLEX 416 cameras only.



Do not use with an extension cable as this will prevent communication between the OBB-2 and 416. The 416 monitors the OBB-2 and prevents it going into deep discharge.



The OBB-2 contains Lithium-Ion cells. The equivalent Lithium content is less than 8 grams. Tested according to UN manual of test and criteria chapter 38.3.



To reduce the risk of fire burns do not disassemble, crush, puncture or short external contacts.



Do not dispose of in fire or water.



Do not expose to temperatures above 60°C.



Use specified charger only.



Charge: 0°C to 40°C.
Discharge: -20° to +50°C.



Remove from camera when discharged, during transport and in storage.



Check the current regulations regarding transportation of Lithium-Ion batteries with your carrier.

Mounting the OBB-2

- Fit the power plug of the OBB-2 into the camera power connector and slide the battery forward ⇒ **photo**.

Removing the OBB-2

- Hold the OBB-2 and press the on-board battery release button ⇒ **photo**.
- Pull the battery backwards until the power connectors disengage.

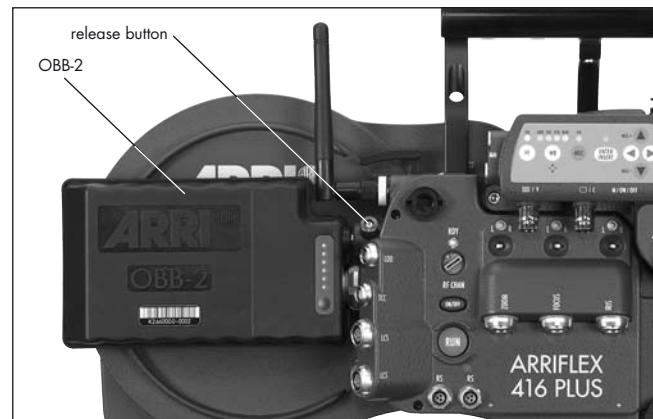



Charging the OBB-2

- Connect the battery to the charger ⇒ **photo**.
- Connect the mains supply.
- The LED on the charger glows orange when the battery is empty
- The LED on the charger glows yellow when the battery is partly full
- The LED on the charger glows green when the battery is fully charged



Do not charge below 0°C.

5.5 Accessory Power Supply

24 V Accessories



*The RS sockets supply the same voltage as the camera power supply.
Ensure that the accessories to be used are suited to the available voltage!*

24 V accessories are normally attached to the RS sockets
⇒ **photo**. 24 V can also be drawn from the “REMOTE” connector. At 24 V, the maximum continuous current for both types of socket together is 2 A, with a peak load of 4 A.

Overload

If the current drawn at the accessory sockets exceeds the allowable maximum, a self-resetting safety circuit interrupts the power supply. If this happens, turn the camera off, unplug all accessories from the camera, wait for one minute and turn the camera back on.

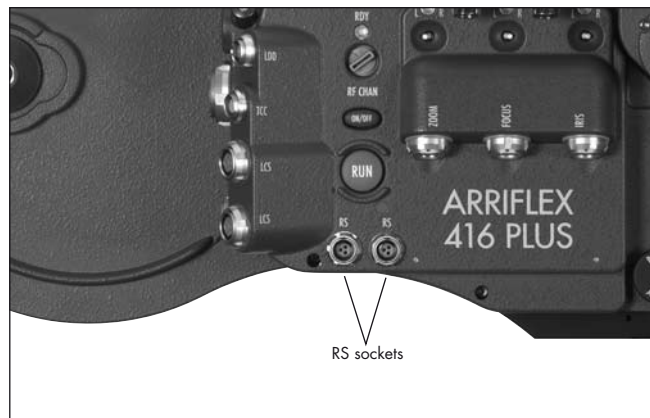



6. Magazines

Only the SHM-3 416 Shoulder Magazine 120/400 can be used with the ARRIFLEX 416. Magazines from the 16 SR 1, 2 & 3 cameras are not compatible.

6.1 Loading the 416 Magazine

Loading the magazine should be practised in daylight with a piece of waste film until the procedure can be carried out confidently in a darkroom or film changing tent.

Cutting the film through the middle of the perforation holes simplifies the loading process considerably. The film head of a fresh roll of film is normally cut in this way.

Step 1: The Feed Side

Load the film into the feed side in absolute darkness (darkroom or film changing tent).

- Remove the loop protector and lay the magazine on a flat surface with its feed side door facing upwards.
- To open the door, flip up the locking grip, depress the safety catch and turn it counter-clockwise ⇒ **photo**.
- Lift up the magazine cover and remove it by pulling the cover to the right.



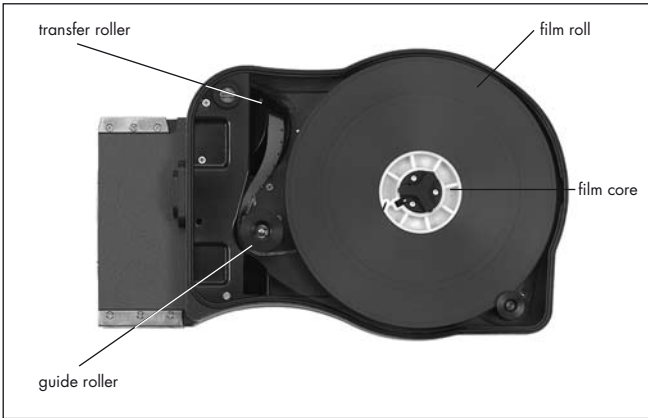
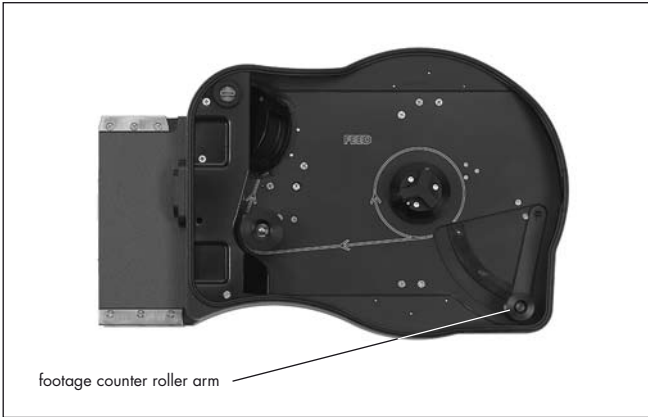

- Swing the footage counter roller arm ⇨ **photo** away from the feed side core holder until it locks in place.
- Remove the film from the film can and black bag.
- Remove the tape from the film head. Ensure that the tape is completely removed and secured out of the way.
- Place the film roll on the core holder so that it unwinds in the direction shown ⇨ **photo**. Press it down fully.



When placing the film on the core holder, do not push on the film itself as it could become conical. Push on the film core instead.

- Hold the film roll still and turn the core holder until the core holder key clicks into the key slot of the film core. Make sure the core holder cannot turn any further.
- Release the footage counter roller arm gently so the roller rests on the outer surface of the film roll. The sides of the roller should overlap the film roll edges ⇨ **photo**.
- Push approximately 15 cm (6") of film into the slit at the top of the angled transfer roller. Then thread the film around the guide roller.
- Hold the film still where it enters the transfer roller and gently back-tension the film roll to remove any slack.
- Replace and lock the feed side magazine door, being careful not to trap any film in the process.
- Check if the door is properly closed before removing the magazine from the changing tent or dark room.

Step 2: The Take-up Side

The following procedures may be carried out in the light.

- Flip the magazine over so that the take-up door is uppermost and the top of the magazine is facing you. The ARRI on the door will be upside down.
- Open the take-up side magazine door and latch back the lay-on roller arm. Fit an empty film core to the take-up core holder making sure that the core holder key is engaged in the key slot of the film core.
- The film head should be protruding from the transfer roller ⇒ **photo**. Check that it is cut squarely through a perforation.
- Thread the film head around the forward guide roller as indicated inside the magazine. Without touching the film core, push the film head into the upper sprocket roller until its teeth engage in the film perforations ⇒ **photo**.
- Once the sprocket teeth have engaged in the film perforations, turn the film core until the film head emerges from the magazine throat.
- Set the loop length by pulling the film head away from you and align it with the loop mark on the bottom of the magazine ⇒ **photo**. Adjust the loop length by turning the take-up film core.
- Now take your hand off the film core – there is enough inertia in the sprockets to maintain the loop length.

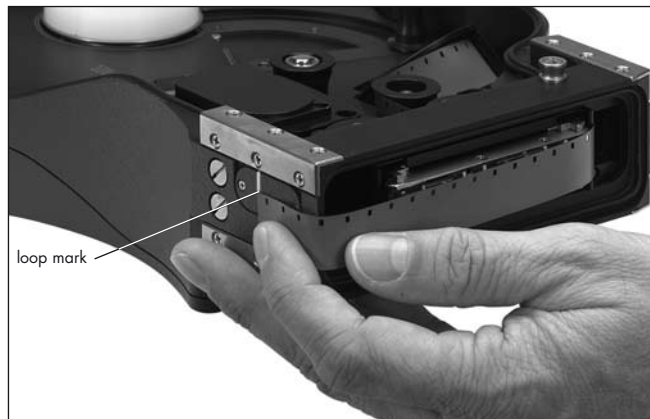
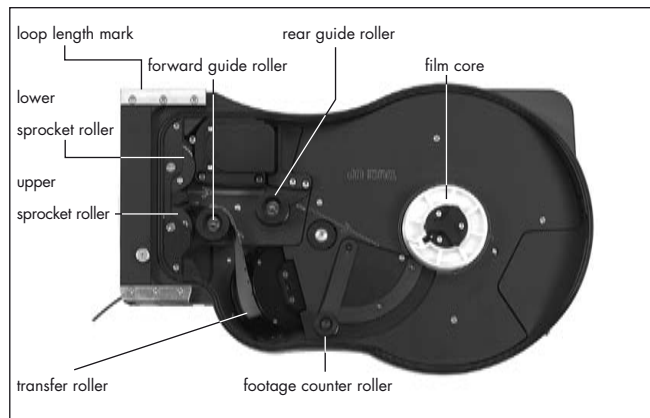

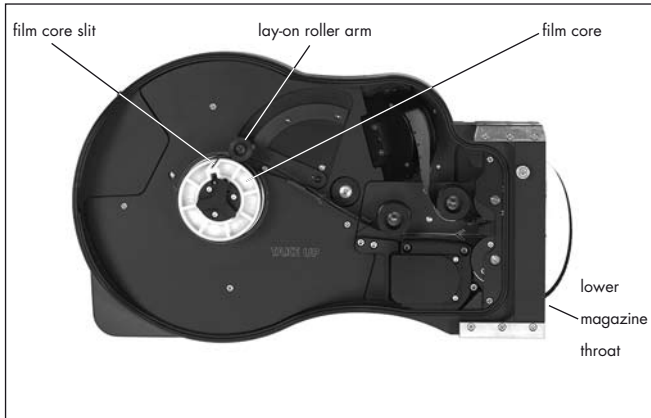

- Hold the film between thumb and middle finger of your left hand, while using your index finger to push the film head into the lower magazine throat slot. The angle at which the film enters is not as critical as it is on the old SR magazines.
- Keep pushing the film in with your index finger until you see the sprockets rotate ⇒ **photo**. Now take hold of the film core again and rotate it counter-clockwise. This will pull the film from the throat into the take-up chamber.
- Thread the film around the rear guide roller following the path indicated in the magazine.
- Insert the film head into the film core and manually wind the core holder two or three turns until the film winds tightly onto the core.
- Unlatch the lay-on roller arm.
- Close and lock the take-up side door.
- If using timecode, set the sensitivity switch according to the table in the Timecode section of this manual. The switch is located at the top left corner of the feed side door ⇒ **photo**.

6.2 Checking the Loop Size

- Turn the magazine so the throat is pointing upwards with the feed side facing you.
- Push the loop to the left so all the slack is below the pressure plate.
- The end of the loop must fall within the white line marked in the lower throat chamber ⇒ **photo**.
- If the loop length is not correct push down the button in the middle of the lower sprocket and turn the sprockets against each other to alter the loop length. Make sure the sprocket engages properly again after changing the loop size. Check loop length again.

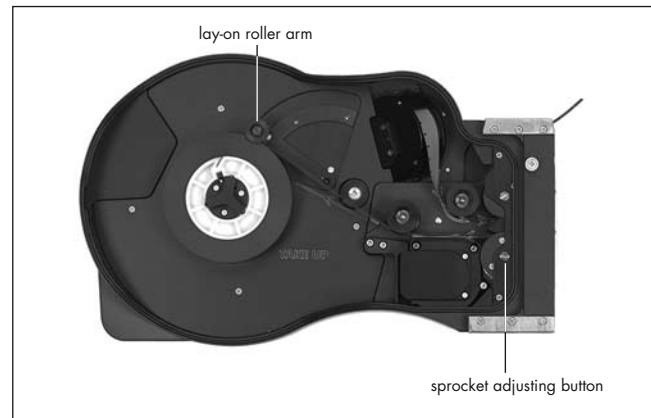
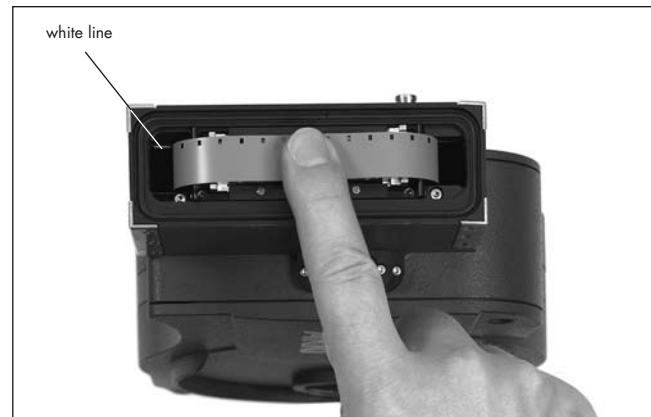

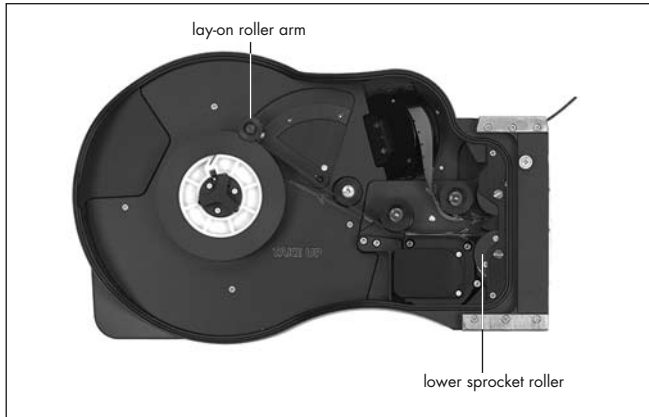

6.3 Removing Exposed Film

If only part of the film roll has been exposed and you intend leaving a 'short end' in the magazine, cut the film loop squarely through a perforation.



The following steps should be carried out in total darkness in a darkroom or changing tent!

- Open the take-up side door by flipping the locking grip upwards and turning the grip counter-clockwise.
- Lift up the door and remove it by pulling it to the left.
- Manually wind the film roll counter-clockwise until the film tail comes free from the lower sprocket roller.
- Swing the lay-on roller arm ⇒ **photo** away from the winding shaft until it locks in place.
- Pull the film roll upwards and off.

Note: When pulling the film roll off the shaft, grip the roll firmly to prevent the middle of the film roll from sagging down.



The film tail should never be pulled to tighten the roll. This causes scratches and static discharging.

6.4 Transport and Storage

Loaded or empty magazines should only be transported or stored with the loop protector ⇒ **photo** attached to avoid damage to the film stock and the magazine throat assembly.

It is recommended that when the ARRIFLEX 416 is transported without a magazine the magazine opening cover should be attached ⇒ **photo**.



7. Camera Body

7.1 Mechanically Adjustable Mirror Shutter

The mirror shutter on the ARRIFLEX 416 can be mechanically adjusted while the camera is switched off. The shutter angle can be adjusted from 180° to 45°. The shutter locks in the following positions: 180°, 172.8°, 150°, 144°, 135°, 90° and 45°.

Setting the Mirror Shutter Angle

- Switch off the camera and disconnect the camera from the power supply!
- Remove the lens or the protective cap from the lens mount receptacle.



Do not touch the reflective surface of the mirror.

- Prevent the shutter from rotating by inserting the flat tip of the red plastic film track cleaning rod from the camera's tool kit into the slot at the mirror shutter centre ⇒ **photo**.
- Insert the shutter tool carefully into the adjustment recess ⇒ **photo**.

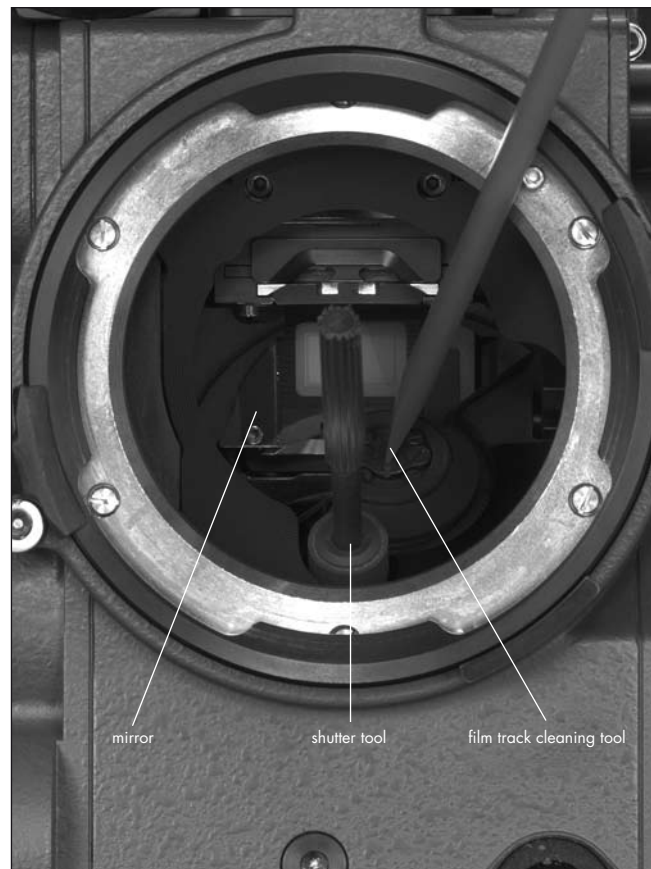

- Turn the shutter tool to set the shutter to the desired shutter opening. The shutter is held in its preset positions by a sprung-ball, which can be felt as the shutter is adjusted. Make sure the shutter registers properly at the set opening.
- Remove the shutter tool and film track cleaning rod



Operation of the camera when the mirror shutter is not correctly locked in position may cause incorrect exposure!

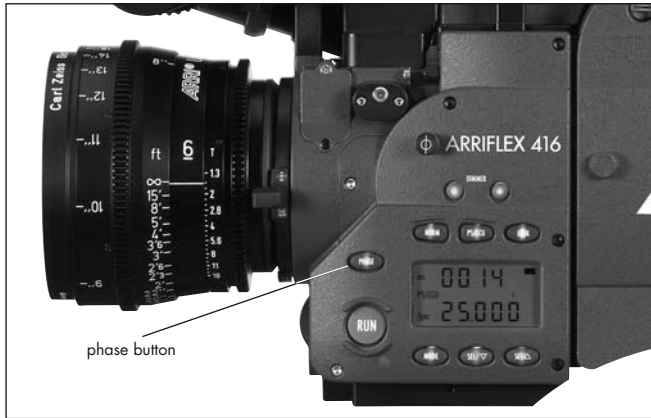

Shutter Angle Measurement

- Holding the “PHASE” button pressed in Standby will make the camera inch forward.
- During this the display shows the measured shutter angle in the upper line. The lower line displays the voltage of the power supply or the percentage of remaining battery capacity or the number of magazine rolls left.



Filming with HMI Light

When lighting scenes with HMI/CID discharge lamps, the intensity of the light will pulse with the power supply frequency unless a flicker-free ballast is used. To achieve constant exposure, the camera's frame rate, the supply frequency of the lighting and the angle of the mirror shutter must all relate to each other. As the camera frame rate and the supply frequency of the lighting are normally fixed, compensation is achieved by adjusting the angle of the mirror shutter.



Make sure you compensate exposure for any change in mirror shutter angle!

The following table indicates the mirror shutter angle that needs to be set:

Supply frequency	50 Hz		60 Hz	
	Frame rate	25 fps	24 fps	25 fps
Shutter angle	Any angle	172.8°	150°	Any angle

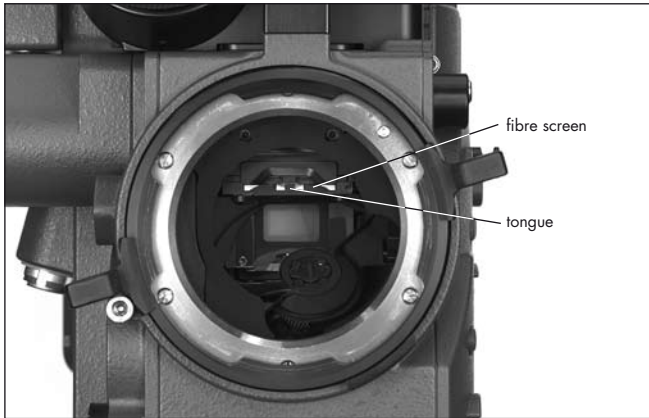
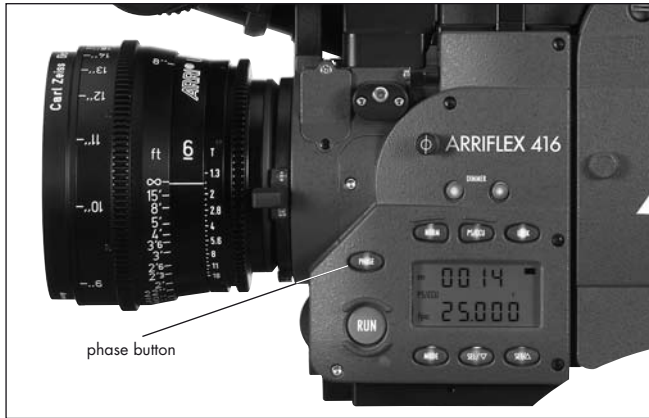

7.2 Exchanging the Fibre Screen

- In Standby, briefly press the "PHASE" button to position the shutter so the mirror surface is protected from damage as far as possible ⇒ **photo**.
- Before exchanging the fibre screen, switch the camera's main switch off and disconnect the camera from the power supply!
- Remove the lens or the protective cap.



Do not touch the mirror surface!

- Using the special forceps (Hirschmann Clamp) from the camera's toolkit, pull the fibre screen ⇒ **photo** out of the holder by its tongue ⇒ **photo**.
- Check that both the fibre screen to be inserted and its frame are completely clean.
- With the special forceps, push the chosen fibre screen into the holder as far as it will go. A sprung-ball catch fixes the fibre screen exactly in the right position.
- Check that the fibre screen is correctly locked in place.

Note: Cleaning or exchanging the field lens is covered in Chapter 14 Maintenance, Cleaning the Field Lens.

7.4 Attaching the Magazine

- Move the magazine release lever safety catch to the open position ⇒ **photo**.
- Press down the magazine release lever ⇒ **photo** and remove the magazine opening cover.
- Remove the loop protector from the magazine.
- Place the magazine's throat in the camera opening and slide the magazine forward into the camera until it latches.
- Flip the magazine release lever safety catch forward to prevent accidental release of the magazine.
- Press the "PHASE" button for a couple of seconds to inch the film.

Note: After a new magazine has been attached or after camera power has been turned on, you should always push the "PHASE" button to perform a loop check (the display shows "LoOP"). This takes about 2 seconds and will engage the pull down claw, check loop size and centre the loop properly.

Note: If the loop check finds that the loop is too short for safe camera performance the message "Error LoOP.S" will show in the camera display. The camera is not ready and will not run. If the loop check finds that the loop is too long for safe camera performance the message "Error LoOP.L" will show in the camera display. The camera is not ready and will not run.

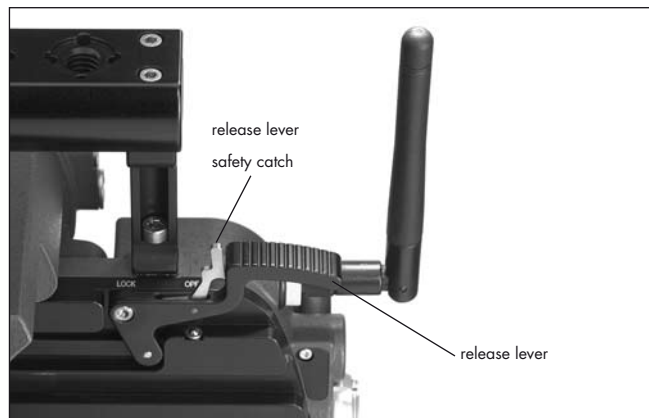

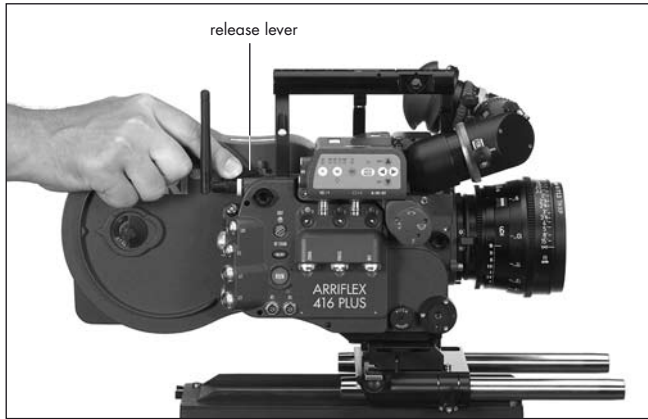
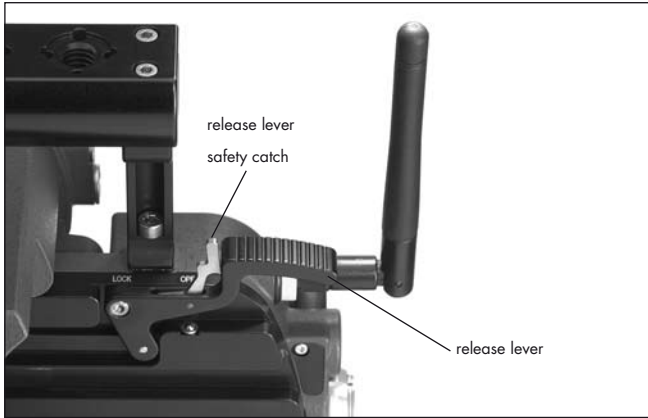

7.5 Removing the Magazine

- Stop the camera if it is running!
- Move the magazine release lever safety catch to the open position ⇒ **photo**.
- Push the magazine release lever down ⇒ **photo** and pull the magazine back and out of the camera.
- Fit a loop protector to the magazine.
- Replace the cover in the camera opening or mount another magazine immediately.

8. Optics

8.1 Lenses

All ARRIFLEX lenses with a PL-mount can be used. Lenses with a \varnothing 41 mm standard or bayonet mount can be used with a suitable adapter. Heavy and long lenses, such as zoom lenses, must be supported at all times.

Attaching Lenses

- Remove the protective cap from the lens mount receptacle by turning the lens lock ring \Rightarrow **photo** counter-clockwise (as viewed from in front of the camera) as far as it will go and then pulling out the protective cap.



Never put your fingers into the lens mount receptacle.

- Push the lens into the lens mount receptacle without catching it at the edges. One of the four slots on the lens mount must fit over the index pin \Rightarrow **photo**.
- Press the lens flat onto the lens mount receptacle and turn the lens lock ring clockwise to tighten.

Note: The camera is permanently set in Super 16 configuration.

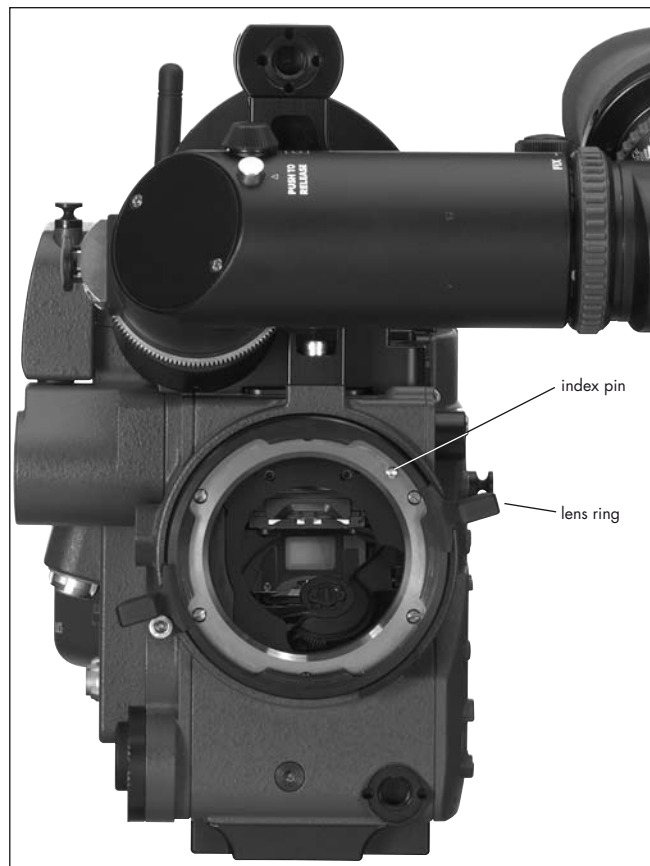



8.2 Viewfinder System

The viewfinder system on the ARRIEFLEX 416 can be swivelled in two axes. The viewfinder image is always upright and correct left-to-right when the viewfinder is swivelled within the main axes ⇒ **photo**.

An 80/20 beamsplitter for the video assist is integrated into the camera body. The viewfinder and the video assist can be used independently of each other.

The Eyepiece

Removing the Eyepiece

- Hold the eyepiece with one hand and with the other turn the knurled ring (eyepiece) ⇒ **photo** in the "OPEN" direction until it unscrews from the eyepiece.
- Remove the eyepiece ⇒ **photo**.

Attaching the Eyepiece

- Position the eyepiece on the viewfinder.
- Move the knurled ring (eyepiece) toward the eyepiece ⇒ **photo** and turn the ring in the "LOCK" direction until it tightens.
- Check that the eyepiece is correctly seated.

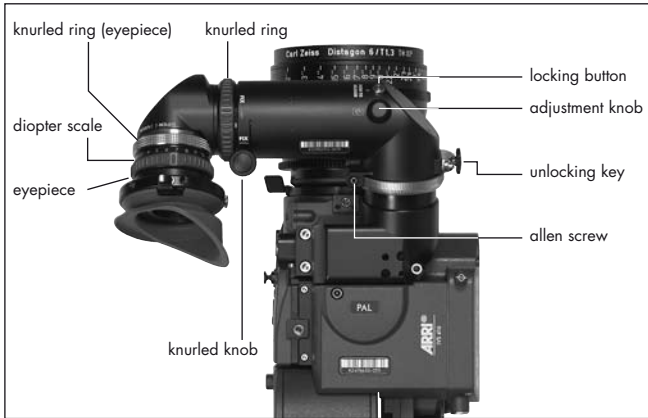

Adjusting the Dioptre

The dioptre compensation is fitted with a scale \Rightarrow **photo** of 1 to 12. Position "6" is normal focus.

- To adjust, turn the ring right/left until the fibre screen markings are totally in focus.

Adjusting the Viewfinder

Turning the Eyepiece

The eyepiece can be rotated 360° around the viewfinder arm. The eyepiece is held in position by friction.

- To set friction, turn the knurled knob \Rightarrow **photo** right/left until the desired friction has been reached.

Swivelling the Viewfinder Arm

The viewfinder arm can be swivelled through 360° left to right. The viewfinder arm can be locked into the horizontal position. The viewfinder arm friction can be altered if necessary by turning the Allen screw \Rightarrow **photo**.

- To adjust the viewfinder arm, release the locking mechanism by pulling the unlocking key \Rightarrow **photo**.
- Turn the viewfinder arm to the desired position.

Note: The unlocking key can be fixed in its open position by turning it.

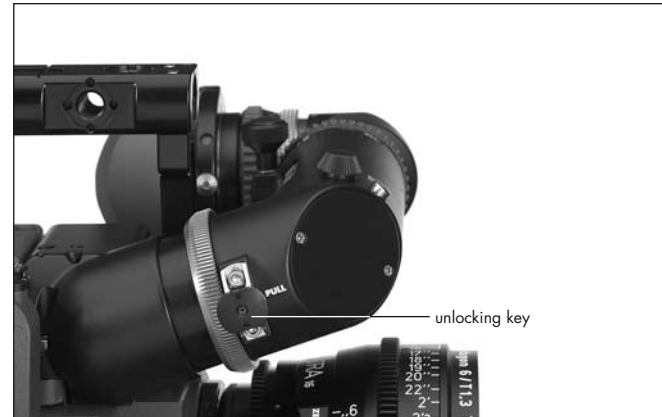

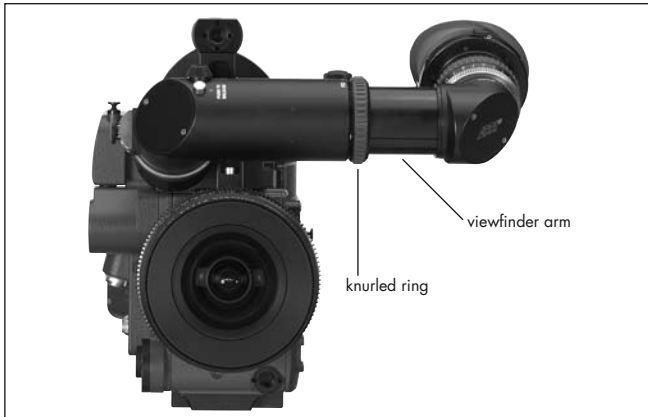

Extending the Viewfinder Arm

The viewfinder arm can be telescoped continuously by approx. 40 mm.

- Turn the knurled ring ⇒ **photo** towards the “LOOSE” position.
- Pull the viewfinder arm ⇒ **photo** out to the desired length.
- Retighten the knurled ring.

Image Orientation Compensation

The viewfinder system is fitted with an automatic image orientation compensation mechanism.

To enable setting a different image position in certain situations, the viewfinder system is additionally equipped with a manually adjustable image orientation mechanism.

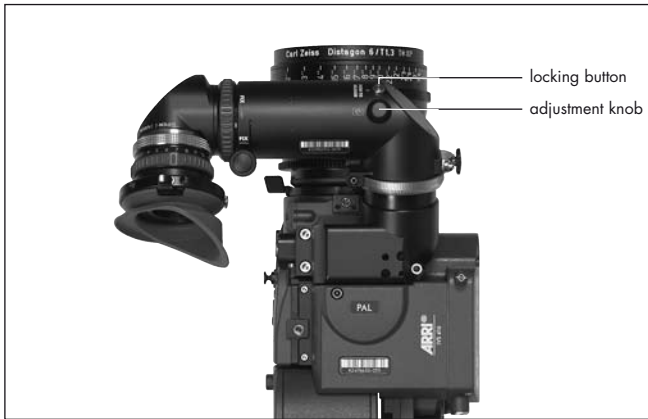

Manually Adjusting Image Compensation

- Press the locking key ⇒ **photo** and hold pressed.
- Turn the adjustment knob ⇒ **photo** until the viewfinder image is in the desired position.

Reactivating Image Compensation

- Turn the adjustment knob ⇒ **photo** until it locks in position. Do not press the locking key.

Note: The automatic image compensation locks in two positions 180° apart. This allows the image compensation to be set to provide an upright image when using a finder extension.

If the viewfinder image is inverted without the finder extension, the image compensation must be adjusted to the opposite locking position.

Inverting the Image

- Press the locking button ⇨ **photo** and keep pressed.
- Turn the adjustment knob ⇨ **photo**.
- Release the locking button ⇨ **photo**.
- Keep turning the adjustment knob ⇨ **photo** until the locking button pops up and the adjustment knob locks in position.

Removing the Viewfinder System

Before removing the viewfinder system, the viewfinder arm should be brought back to its normal position.

- Loosen the three fastening screws ⇨ **photo**.
- Pull the viewfinder system up and off the camera body.
- If the camera is to be used without the viewfinder, fit the cover to protect the beamsplitter prism.

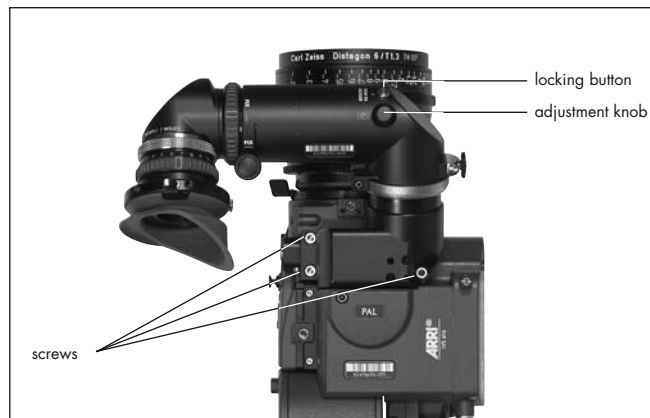

Attaching the Viewfinder System

- Position the viewfinder system on the camera body from above.
- Tighten the fastening screws.

Viewfinder Warnings

A LED glows when the camera is not running at the set speed (ASY). This LED blinks when the battery voltage is low (BAT).

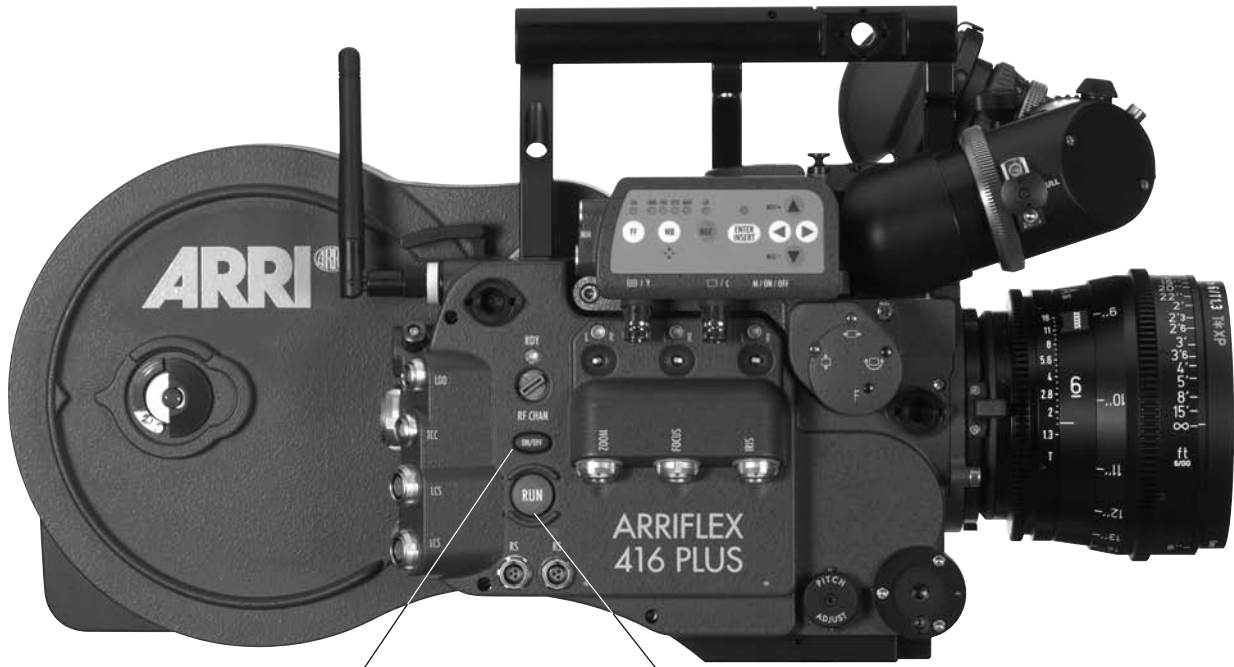

ON/OFF button

RUN button

9. Camera Operation

9.1 Main Camera Switch

- If using a mains unit, switch it on.
- Connect the camera to the mains unit or battery.
- Push the “ON/OFF” button ⇒ **photo** to turn the camera on. Push the “ON/OFF” button for approx. 3 seconds to turn the camera off again.

Note: If the camera power supply is interrupted, the camera remembers whether it was on or off before the interruption and returns to that state when power is restored. This is useful if the camera is rigged in a situation where access is difficult as the battery can be changed without having to press the “ON/OFF” button.

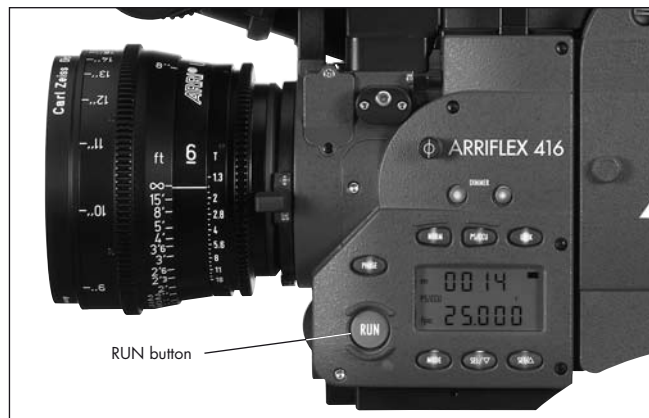

9.2 Running and Stopping the Camera

A “RUN” button is located on both sides of the camera ⇒ **photo**.

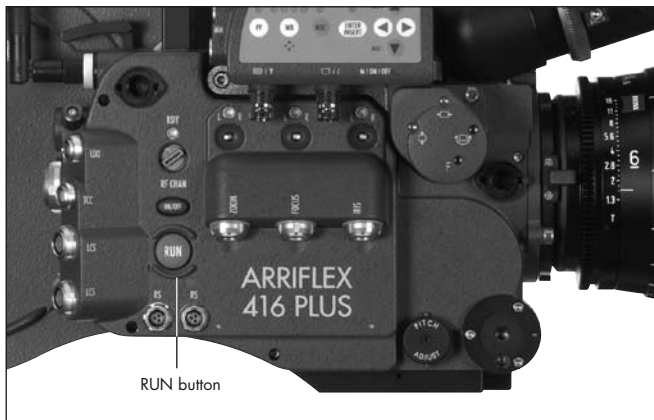
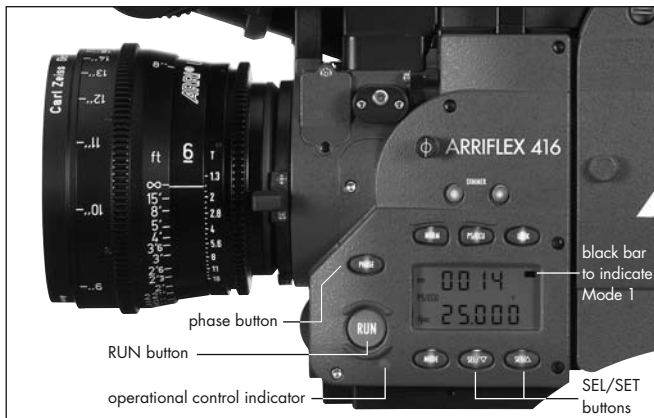

Running the Camera

If the operation control indicator glows red while in Standby, the camera is not ready and will not run (see “Overview of Display Symbols”).

- Briefly press the “RUN” button. While the camera is running up to speed, the operation control indicator ⇨ **photo** glows red. Once the set frame rate has been reached, the operation control indicator turns green.

Note: If the “PHASE” button has not been pushed after power on or after a new magazine has been attached, the first time “RUN” is pressed the camera performs a 2 second loop check before running.

Stopping the Camera

- Press the “RUN” button again ⇨ **photo** briefly. While the camera is slowing down the operation control indicator glows red. The mirror shutter automatically stops in a position that enables unrestricted viewing through the viewfinder. On reaching this position, the operation control indicator flashes green before going out.

Inching

The camera can be inched by pressing the "PHASE" button while the camera is in Standby. If the "PHASE" button is only pressed briefly, the mirror shutter rotates a part revolution to enable an unrestricted view of the film gate (e.g. for checking the gate). If the "PHASE" button is held pressed longer, the camera will inch forward at approximately 1 fps. During inching the upper line of the display indicates the measured shutter angle, the lower line the measured voltage of the power supply.



While inching, the camera speed is not exactly controlled. As this can cause faulty exposures, do not film while inching.

9.3 Displaying and Setting Operational Parameters

The currently set operational parameters on the ARRIFLEX 416 are displayed on the camera display ⇒ **photo** in various modes. The desired mode is selected via the "MODE" button. In each mode the corresponding operational parameters can be set using the "SEL" and "SET" buttons ⇒ **photo**.

Note: The Mode numbers are shown in the display between the upper and the lower line. Mode 1 is also indicated ⇒ **photo** in the display by a black horizontal bar.

To prevent an unintentional alteration of the operational parameters the buttons "SEL", "SET", and "PHASE" can be locked using the "LOCK" button. If a button is pressed when the display is locked, the display will show the "OFF" sign. If the display is locked, this is indicated by the "LOCK" symbol in the display.

Note: Locking the "PHASE" button has no influence on the inching function.



Locking the "SEL" and "SET" buttons has no influence on accessories such as the RCU-1.

Overview of Display Modes

Mode 1 is displayed:
 after switching on the camera,
 after pressing the "RUN" button
 or 30 seconds after the last operation.

	1st Display Line	2nd Display Line	Adjustment Possibility
Mode 1	total exposed film counter (m/ft) or take counter (m/ft)	frame rate (fps) or ESU in standby and frame rate (fps) while running (external control connected)	setting/re-setting of total exposed film counter selection of a standard frame rate
Mode 2	programmed frame rate (PS) ESU – external control connected	programmed frame rate (fps)	programmed frame rate
Mode 3	total exposed film counter (m/ft) or take-counter (m/ft)	power supply voltage (V), or (with OBB-2 fitted) capacity in percent or remaining magazines	unit of measurement (m/ft) configuration of the film counter press SET to set battery warning level
Mode 4	timecode hours:minutes press SEL to show TC error codes	timecode seconds:frame rate press SEL to show TCS settings and activity of clock adjustment	press and hold SET for 3 seconds to turn TC on/off press and hold SEL and then press and hold SET for 3 seconds to reset clock adjustment to default
Mode 5	timecode user bits (1st 4 digits)	timecode user bits (2nd 4 digits)	setting of user bits (0-9, A-F)
Mode 6	sequence and volume of the acoustic warning signal	brightness of the keypad	beep at start, stop, neither or both beeper volume keypad backlight brightness
Mode 7	GLo – RGB ARRIGLOW	ARRIGLOW color r, G & B values (0-16) for User color	preset colors 1-8 and User adjustable color r, G & B values (0-16) for User color

Overview of Display Symbols

Symbol Meaning	
■	glows The display is in Mode 1.
bat	glows Battery voltage too low
asy	glows Asynchronous operation (camera is not running at set frame rate)
fps	glows display shows current frame rate blinks ESU is connected and no sync-frequency is available
7 6 5..	glows Mode number
NORM	glows camera will run the set NORM speed
PS/CCU	glows camera will run the set PS speed or the speed set by an accessory
LOCK	glows parameter change buttons are locked
m ft	glows unit of measurement used by film counters
◁	glows display shows the current shutter angle
TC	glows display shows timecode
UB	glows display shows Userbits
end	glows film end

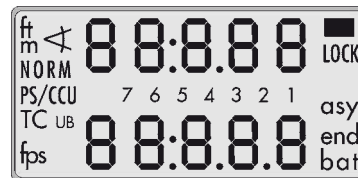



Mode 1

total exposed film or takelength



Mode 3

take length or total exposed film

Film Counter

Displaying the Film Counting Values (Modes 1 and 3)

Film counting values are shown in Modes 1 and 3. Two different counting values are shown respectively:

- the total amount of exposed film or
 - the take length (amount of film used in an individual take)
- A "t" in the first digit of the upper display line indicates the display of take length.

Setting the Film Counter Configuration (Mode 3)

The display configuration can be set individually. The two shown combinations are possible:

The desired display configuration is set in Mode 3:

- Change from Mode 1 to Mode 3 by pressing the "MODE" button twice.
- Press the "SEL" button twice; the first digit in the upper display line blinks.
- Within three seconds, press the "SET" button.
- The currently set counting value of Mode 3 is displayed. The corresponding counting value in Mode 1 is automatically altered.

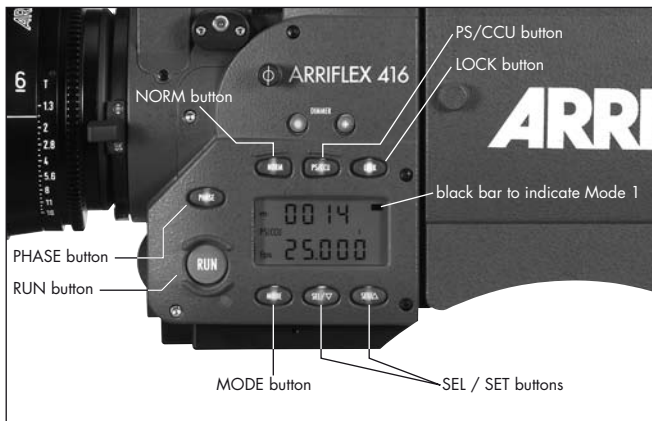

Resetting the Film Counter (Modes 1 and 3)

- Change to the mode which shows the total exposed film counter ("MODE" button).
- The total exposed film counter can be set to zero by pressing the "SET" button (for at least 1.5 seconds) while in Standby.
- The take length counter is automatically reset each time the camera is started.

Setting the Total Exposed Film Counter (Mode 1)

- The Total Exposed Film Counter can only be set in Mode 1 (see Setting the Film Counter Configuration above).
- Use the "SEL" button to select the total exposed film counter digit you wish to change, which will start to flash.
- Use the "SET" button to change the value of the flashing digit.

Changing the Unit of Measurement (Meters/Feet) (Mode 3)

- Change from Mode 1 to Mode 3 by pressing the "MODE" button twice.
- Press the "SEL" button once; the symbol m/ft blinks.
- Press the "SET" button within three seconds to change the unit of measurement.

Displaying the Angle of the Mirror Shutter (Mode 1)

- Press and hold the "PHASE" button while in Standby. The set angle of the mirror shutter appears in the upper display line. The camera runs at inching speed.

Setting the shutter angle: see Chapter 7.

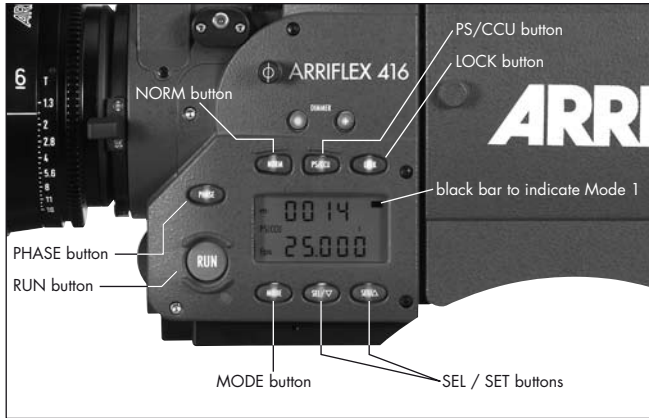

Frame Rates

The ARRIFLEX 416 offers the possibility to set and store two frame rates. It is possible to select and store:

- a standard frame rate (23.976, 24, 25, 29.97 and 30 fps)
- and a freely programmed frame rate between 1 and 75 fps in increments of 0.001 fps.

The frame rate is activated via the “NORM” and “PS/CCU” buttons ⇒ **photo** on the left of the camera. The “NORM” setting corresponds to the standard frame rate, the “PS/CCU” position to the freely programmed frame rate.

Selecting a Standard Frame Rate (Mode 1)

Standby Operation

- The camera must be in Mode 1 and the camera must be set to “NORM”.
- Press the “SEL” button repeatedly until the desired frame rate is selected. Within 3 seconds, confirm this choice by pressing the “SET” button, otherwise the initial setting is retained.

Note: If the total exposed film counter is displayed in Mode 1, pressing “SEL” first steps through the digits of the total exposed film counter before the choice of frame rate is offered.

Setting a Programmed Frame Rate (Mode 2)

Standby Operation

- Change from Mode 1 to Mode 2 by pressing the "MODE" button once.
- Press the "SEL" button repeatedly until the digit to be set blinks.
- Press the "SET" button repeatedly until the desired value is reached.
- Repeat this procedure until all digits are set to the desired values. A final confirmation of the set frame rate is not necessary.

Note: The frame rate can be set between 1 and 75 fps forward only.

Note: The programmed frame rate is stored in non-volatile memory (which means it is retained even when the camera is without power).



Changing the Frame Rate while the Camera is running

By means of the "NORM" and "PS/CCU" buttons it is possible to switch between the standard frame rate ("NORM") and the programmed frame rate ("PS/CCU") while the camera is running.

Fine Tuning the Programmed Frame Rate (PS Mode)

Fine tuning of the programmed frame rate can be carried out while the camera is running by means of the buttons "SEL" (slower) and "SET" (faster). The setting can be adjusted in increments of 0.001 fps.

- Ensure the camera is in "PS/CCU" mode.
- Run the camera.
- Press the "MODE" button once to change to Mode 2.
- With the buttons "SEL" (slower) and "SET" (faster) change the frame rate.



Shifting phase

After the camera has run up, the frame rate can be temporarily increased by 0.2 fps while the button the "PHASE" is held pressed ⇒ **photo**. This is normally used when synchronizing to an interlaced video signal – look through the viewfinder and hold the "PHASE" button pressed until the bar in the video picture is no longer visible on the monitor. Always confirm results with a film test.

Displaying Power Supply Voltage (Mode 3)

- Change from Mode 1 to Mode 3 by pressing the "MODE" button twice. The power supply voltage is shown in the lower line of the display.

Note: If the camera has an OBB-2 attached, the options of battery capacity (in percent) or remaining magazines can be displayed instead of voltage.

Displaying On-board Battery information (Mode 3)

The options in this section are only available when an OBB-2 on-board battery is attached.

- Change from Mode 1 to Mode 3 by pressing the “MODE” button twice. The display shows the battery voltage.
- Press the “SEL” button three and the display changes to capacity, shown as e.g. “CP. 72%”. “CP” blinks. This example would mean the attached OBB-2 battery has a remaining capacity of 72%.
- Press the “SEL” button once and the display indicates the remaining number of magazines the battery can run. The display might show “CAS.4”, meaning 4 complete magazines (or ,cassettes’ in German) can still be run. “CAS” blinks.
- Press “SEL” once more and the display returns to showing supply voltage.
- Press “SET” while the selection you want is blinking to chose that option.

Note: When an OBB-2 is attached to the camera, the low battery warning is derived from the battery’s capacity.

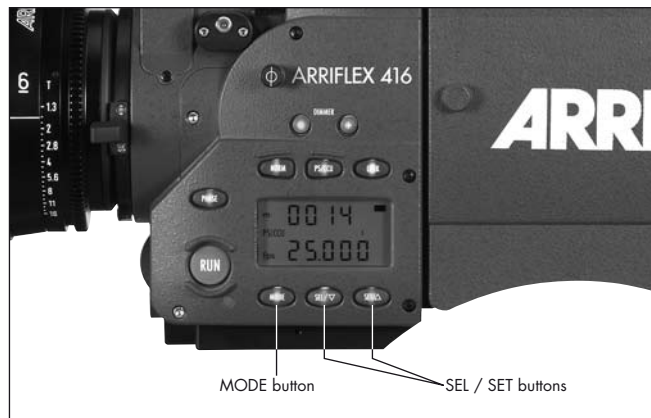

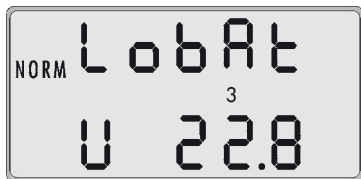
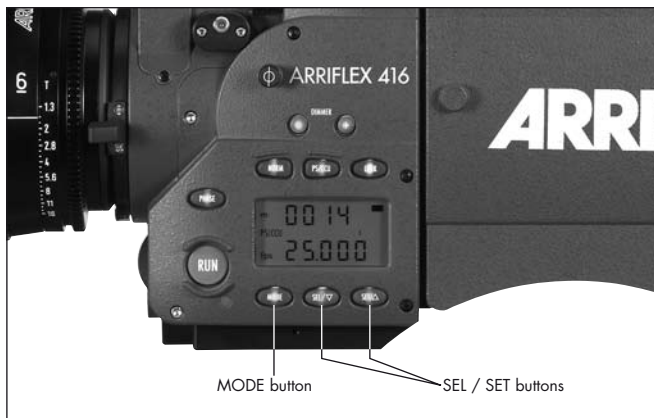

Setting the Low Battery warning level (Mode 3)

When the 416 is not powered by an OBB-2, it is possible to set the threshold at which the Low Battery warning is triggered. It can be set anywhere between 20.0 and 29.9 volts.

- Change from Mode 1 to Mode 3 by pressing the "MODE" button twice.
- Press the "SET" button. The currently set Low Battery warning level is displayed for 3 seconds.
- To change the level, press the "SEL" button 3 times to select the 2nd voltage digit or 4 times to select the 3rd voltage digit. The selected digit will blink.
- Adjust the blinking digit with the "SET" button.
- Once the 2nd and 3rd voltage digits are set as required, press the "SEL" button once to exit the adjustment mode.

Displaying the Timecode Time and Frame Rate (Mode 4)

- Press the "MODE" button until the display shows Mode 4. The display shows the current timecode value. The top line shows "Hours:Minutes". The bottom line shows "Seconds:TC generator frame rate".

Note: The timecode generator frame rate matches the camera's frame rate.



Turning Timecode Recording On and Off (Mode 4)

Timecode recording is only possible at the Standard Speeds of 23.976, 24.00, 25.00, 29.97 & 30.00 fps.

- Press the "MODE" button until the display shows Mode 4.
- Press and hold the "SET" button until the "TC" symbol appears (ON) or disappears (OFF).

Note: For timecode recording a Timecode Module must be fitted to the magazines.

Note: Timecode recording is also turned on when the camera receives a valid timecode signal into the "TCC" connector.



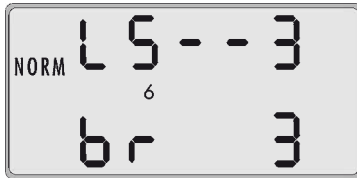

Displaying and Setting the Timecode User Bits (Mode 5)

User Bits are automatically input with the timecode signal but they may also be set manually in Mode 5.

- Press the "MODE" button until the display shows Mode 5.
- Use the "SEL" button to select the digit you wish to change. The selected digit will flash.
- The "SET" button changes the value of the flashing digit.
- Repeat the last two steps for all the digits that need to be changed.

Note: User Bits are hexadecimal so only values between 0 - 9 and A - F are available.

Setting the brightness of the button illumination (Mode 6)

- Change from Mode 1 to Mode 4 by pressing the "MODE" button five times.
- Press the "SEL" button three times to activate the display for setting the button illumination.
- Select the desired brightness using the "SET" button.
 - 0...off
 - 3...maximum brightness

Switching the Beeper On and Off (Mode 6)

Standby Operation

- Press the "MODE" button until the display shows Mode 6.
- By pressing the "SEL" button once, activate the display for setting the Beeper.
- Within three seconds, press the "SET" button to select one of the four settings.
- Pressing the "MODE" button confirms the selection.

Display	Beeper on start	Beeper on stop
LS __	off	off
LS _	on	off
LS _	off	on
LS --	on	on

Setting the Volume of the Warning Signal (Mode 6)

- Press the "MODE" button until the display shows Mode 6.
- Press the "SEL" button two times to activate the display for setting the Beeper volume.
- Select the desired volume with the "SET" button.
 - 0...off
 - 3...maximum volume

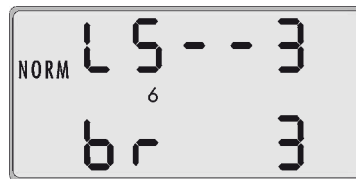

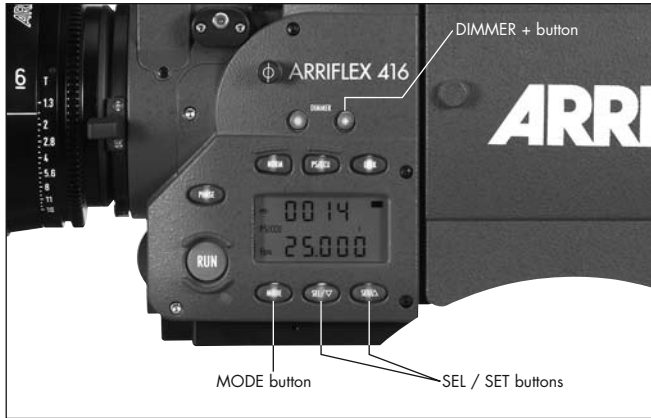

Selecting a Preset ARRIGLOW Color (Mode 7)

- Push the “+” DIMMER button on the camera left side so you can see the ARRIGLOW in the viewfinder.
- Press the “MODE” button until the display shows Mode 7.
- Press the “SEL” button to make the ARRIGLOW color number flash.
- Pressing the “SET” button will cycle through preset color numbers 1 - 8 and then U, the user-adjustable color.
- Stop at the color you like – no confirmation is necessary.



Setting a User-Adjustable ARRIGLOW Color (Mode 7)

- Push the “+” DIMMER button on the camera left side so you can see the ARRIGLOW in the viewfinder.
- Press the “MODE” button until the display shows Mode 7.
- Press the “SEL” button to make the ARRIGLOW color number flash.
- Press the “SET” button until U appears.
- Pressing the “SEL” button will cycle through the “r” (red), “G” (green) and “B” (blue) values of the user color.
- Pressing the “SET” button changes the value from 0 (no color) up to 16 (maximum color).
- Stop when the color is as you like it – no confirmation is necessary.

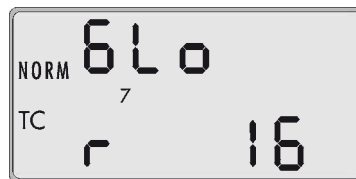

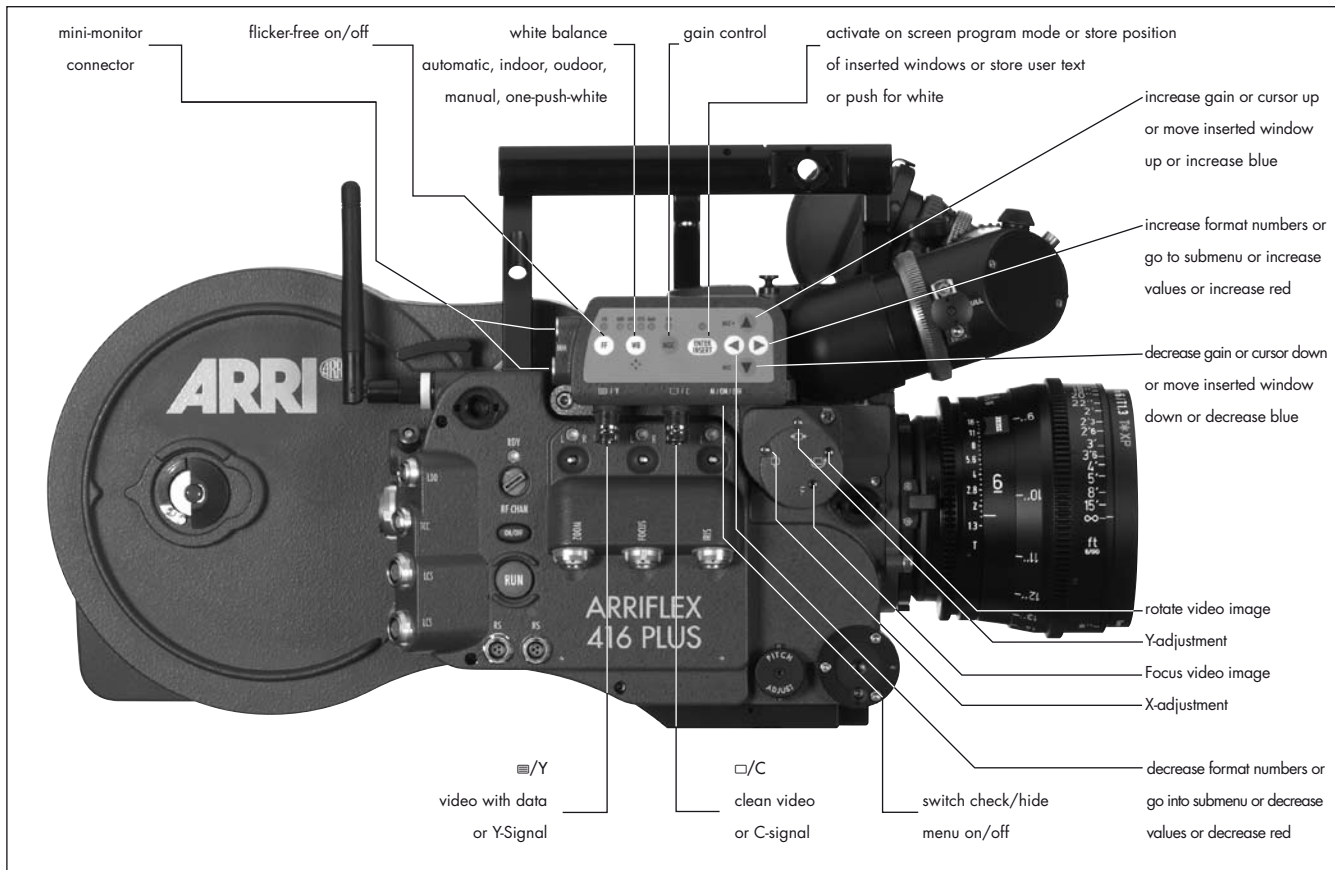

10. Video Assist System

10.1 General Description of the IVS

The Integrated Video Assist System (IVS) for the ARRIFLEX 416 brings the highly praised video assist systems from the ARRIFLEX 435, ARRICAMS and ARRIFLEX 235 to the ARRIFLEX 416. It resembles the IVS 235 control structure and of course offers the same unsurpassed image quality combined with a state-of-the-art inserter to add frame lines, camera status, LDS information and text to the video image.



New Features

- **Electronic image sharpening**
The 416 IVS has an electronic sharpness control which can be adjusted to optimize the look of the video output.
- **Color Bar Generator**
A new menu option allows the user to generate color bars so that monitors being fed from the IVS can be adjusted correctly.
- **One Push White**
Automatic white adjustment by pointing the lens at a white surface and pressing the One Push White Key
- **2 x Mini Monitor connectors**
The IVS offers two Mini-Monitor connectors for use with a 12 V LCD monitor and a wireless video transmitter. The Mini-Monitor connectors have a combined output power of up to 36 W (output current 3 A).
- **Wrong Cable Warning**
An LED illuminates to indicate a bridge between camera and video grounds. This warning is to prevent damage to the IVS and/or camera

Main Features

- Integrated into the camera body
Instead of a bulky add-on, the video assist is integrated into the camera without additional cabling.
- High sensitivity
A high-speed lens with an aperture of 1 : 2.0 and one of the most sensitive CCD Chips available on the market combine to provide an excellent color video image in editing quality even when the lighting is set for high-speed film stock that will be pushed during processing.
- High resolution
The design of the new IVS optics was based around the ARRIFLEX 416 viewfinder and results in an image quality which cannot be attained by add-on solutions.
- Flicker free
An integrated digital frame store enables the video camera to be synchronized to the film camera's mirror shutter and provides a flicker free video image from 1 fps (in manual gain control mode) up to maximum speed because the video image is always taken at the ideal position of the mirror shutter. Flicker free can be switched off to bypass the digital frame store and to have minimal delay in the video system.
- Full white balance control
In addition to the standard indoor white balance setting of 3200 K, an outdoor setting of 5600 K and an automatic adjustment, the red and blue channels can be fine tuned for manual white balance. The 416 IVS also includes a one push white key.
- Line Interpolation
Resolution is improved in camera "RUN" mode by using line interpolation. This results in an image approaching field resolution.
- Store and recall settings
All settings can be stored and recalled. This allows you to adjust all the settings for indoor shooting, store them, shoot some exterior scenes, then go back indoors and recall the previous settings.
Up to 6 settings can be stored.
- Integrated frame line inserter
Frame lines can be electronically added to the video image. This ensures that the lines are visible even in difficult conditions. The area outside the frame lines can be darkened electronically in 4 different steps to emphasize the important image area.

- **Camera status display**
Camera status information, e.g. camera speed and film counter data are passed on a bus interface from the camera to the video assist and can be displayed in a camera status line on the monitor.
- **Lens Data Information**
Lens information, such as lens type, focal distance, depth of field, iris and focal length can be electronically inserted in the video image if they are available, e.g. from a lens data archive.
- **System display**
Camera system information is available in the video assist. Thus, it is possible to see camera warnings such as low battery on the monitor.
- **Integrated text inserter**
Additional text such as take numbers or the production name can be added to the video image by entering the text on the IVS.
- **Y/C Outputs**
The usual composite outputs can be switched to an Y/C output (S VHS) for an even better video image without annoying color artefacts, with or without data inserted into the video image. The Y/C output uses two BNC sockets.
- **On-Screen programming**
All functions, which do not directly affect the image appearance, such as frame lines, can be conveniently programmed with an on-screen programming menu on the video monitor.
- **Dedicated controls**
Important image changes, such as gain or white balance, can be performed in parallel to the on-screen programming with dedicated keys.
- **Image compare function**
It is possible to store a chosen image and compare it against the live input. This clearly shows the difference between the images, e.g. during stop effect shots.
- **Automatic and manual gain control**
The gain is controlled automatically to its best value but can also be set manually.

Note: The IVS package already includes a lens for Super 16, a 1.5 mm Allen key for image adjustment and a Y/C (S VHS) cable.

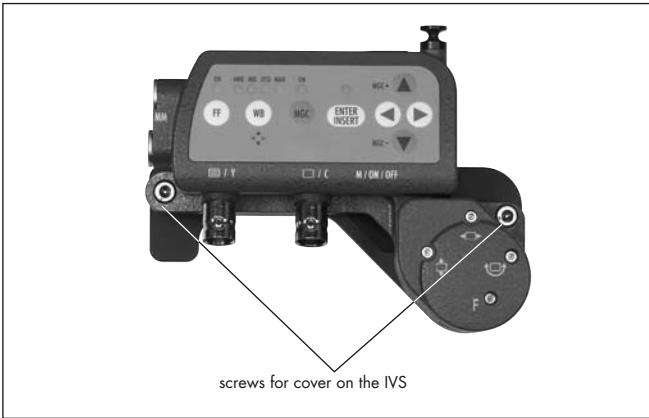
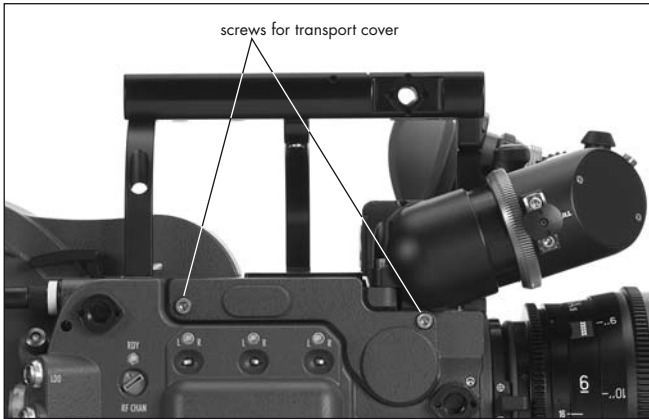

10.2 Setup

10.2.1 Installation

A 3 mm Allen key is used for installation.

- Undo the two screws holding the transport cover ⇒ **photo** and remove it.
- Remove the IVS transport cover from the video assist by undoing the two screws on the IVS ⇒ **photo**.

Note: It may be useful to screw the camera transport cover to the IVS transport cover to store them together as a pair because they are usually required at the same time.

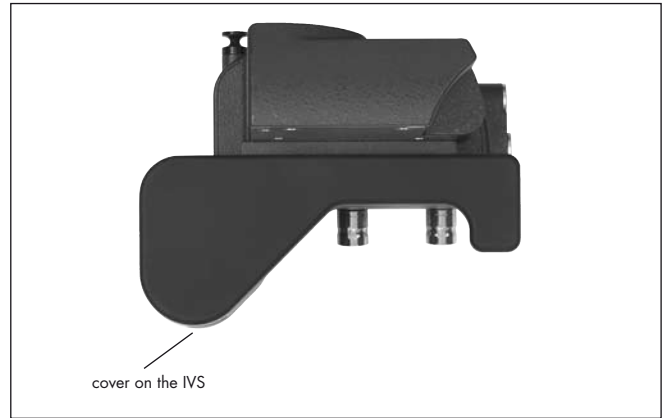

- Attach the video assist to the ARRIFLEX 416 by fitting it to the camera right side in the direction marked ⇒ **photo**.
- Tighten the two screws on the camera right side of the IVS first ⇒ **photo** and then tighten the third screw into the top of the camera ⇒ **photo**.

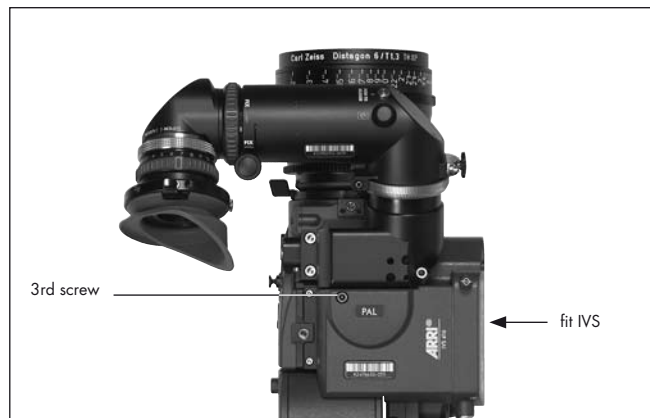

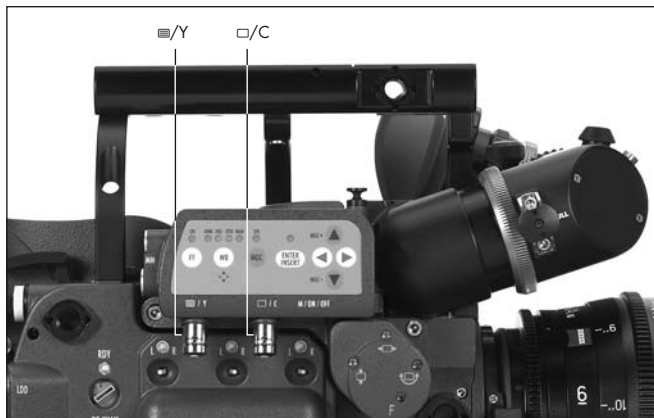

10.2.2 Cabling

Outputs



If it is intended to use composite outputs but it is not known whether the BNC connectors are switched to composite or to Y/C, connect the cable expecting the composite signal to the ≡/Y connector first and check the settings (BNC OUT VBS or Y/C) in the menu video/text adjust. Please see next chapter Composite Video Outputs.

The IVS has two BNC sockets, which can be switched to output two independent composite signals or one Y/C signal. Additionally, there are two outputs for a mini-monitor and wireless video transmitter.

Composite Video Outputs



Composite video is only available when the output is switched to VBS out.

- To switch to composite video (VBS mode), enter the main menu by pressing the Enter/Insert key  for more than 3 seconds. Go to sub menu VIDEO/TEXT ADJUST. The menu line BNC OUT can be switched between VBS and Y/C. See chapter 10.4 Inserter Facilities for information on the on-screen program mode.

The difference between the outputs is that there is normal, clean video on the one connector and video with burnt-in data on the other.

In the clean video output, marked with the □/C symbol ⇒ **photo**, almost no electronic information is inserted. Only a rolling bar at the button left corner of the video image indicates a running film camera.

In the video with data output, marked with the ≡/Y symbol ⇒ **photo**, additional data, such as format marks or camera status information, can be inserted.

```

MENU VIDEO/TEXT ADJUST
- FLICKERFREE      ON
- LINE INTERP.    ON
- SHARPNESS        2
-> - BNC OUT        VBS
    Y/C DATA
- GENLOCK          OFF
- MINI MON DATA  OFF

- TXT WHITE LEV.   2
- TXT INVERS       OFF
- TXT FINE POS.    2

- EXIT
  
```

The outputs are standard BNC sockets for 75 Ω terminated video signals. Both outputs can be used simultaneously.

```
MENU VIDEO/TEXT ADJUST
- FLICKERFREE      ON
- LINE INTERP.    ON
- SHARPNESS        2
-> - BNC OUT         Y/C
- Y/C DATA        OFF
- GENLOCK          OFF
- MINI MON DATA  ON

- TXT WHITE LEV.   2
- TXT INVERS       OFF
- TXT FINE POS.    2

- EXIT
```

Y/C Output

Y/C output offers even better, S VHS quality, compared to the composite video output. There are also clean video and video with data signals available in Y/C mode.



Y/C video is only available when the output is switched to Y/C out.

- Use the on-screen program mode to switch between composite and Y/C. Enter the main menu by pressing the Enter/Insert key  for more than 3 seconds. Go to sub menu VIDEO/TEXT ADJUST. The menu line BNC OUT can be switched between VBS and Y/C. See chapter 10.4 Inserter Facilities for information on the on-screen program mode.

In Y/C, you can choose between the clean video or video with data signals, which come from the same pair of connectors.

- To switch between clean video and video with data, use the on-screen program mode. Enter the main menu by pressing the Enter/Insert key  for more than 3 seconds. Go to sub menu VIDEO/TEXT ADJUST. The menu line Y/C DATA, which can only be reached if BNC OUT is on Y/C, switches between clean video and video with data on the Y/C signal. The line displays Y/C DATA ON or OFF. See chapter 10.4 Inserter Facilities for information on the on-screen program mode.

```

MENU VIDEO/TEXT ADJUST
- FLICKERFREE      ON
- LINE INTERP.    ON
- SHARPNESS        2
- BNC OUT          Y/C
-> - Y/C DATA      ON
- GENLOCK          OFF
- MINI MON DATA  ON

- TXT WHITE LEV.   2
- TXT INVERS       OFF
- TXT FINE POS.    2

- EXIT
  
```

In the clean video output almost no electronic information is inserted. Only a rolling bar at the lower left corner of the video image indicates the film camera is running.

In the video with data output, additional data such as format marks or camera status information can be inserted.

An adapter cable from the two BNC connectors to a standard Y/C connector is included in the IVS package on initial delivery. Connect the red end to the □/C output and the white end to the ≡/Y socket → **photo**.



```
MENU VIDEO/TEXT ADJUST
- FLICKERFREE      ON
- LINE INTERP.    ON
- SHARPNESS        2
-> - BNC OUT         Y/C
- Y/C DATA        OFF
- GENLOCK          OFF
- MINI MON DATA  ON

- TXT WHITE LEV.   2
- TXT INVERS       OFF
- TXT FINE POS.    2

- EXIT
```

Black and White Output

The Y part of the Y/C output is a standard black and white signal. To get black and white, use a standard BNC cable with 75 Ω connected to the \equiv /Y output and switch to Y/C out.



Black and white or Y signal is only available if the output is switched to Y/C out.

- Use the on-screen program mode to switch between composite and Y/C. Enter the main menu by pressing the Enter/Insert key  for more than 3 seconds. Go to sub menu VIDEO/TEXT ADJUST. The menu line BNC OUT can be switched between VBS and Y/C. See chapter 10.4 Inserter Facilities for information on the on-screen program mode.

There are clean video and video with data signals available from the same connector.

- To switch between clean video and video with data, use the on-screen program mode. Enter the main menu by pressing the Enter/Insert key  for more than 3 seconds. Go to sub menu VIDEO/TEXT ADJUST. The menu point Y/C DATA, which can only be reached if BNC OUT is on Y/C, switches between normal video and video with data on the Y/C signal. The line displays Y/C DATA ON or OFF. See chapter 10.4 Inserter Facilities for information on the on-screen program mode.

```

MENU VIDEO/TEXT ADJUST

- FLICKERFREE      ON
- LINE INTERP.    ON
- SHARPNESS        2
- BNC OUT          Y/C
-> - Y/C DATA      ON
- GENLOCK          OFF
- MINI MON DATA  ON

- TXT WHITE LEV.   2
- TXT INVERS       OFF
- TXT FINE POS.    2

- EXIT
  
```

In the normal video output almost no electronic information is inserted. Only a rolling bar at the lower left corner of the video image indicates the film camera is running.

In the video with data output, additional data such as format marks or camera status information, can be inserted.

The /Y socket is standard BNC for 75 Ω video outputs
 ⇨ **photo**.



```

MENU VIDEO/TEXT ADJUST
- FLICKERFREE      ON
- LINE INTERP.    ON
- SHARPNESS        2
- BNC OUT          Y/C
- Y/C DATA        ON
- GENLOCK          OFF
-> MINI MON DATA  ON

- TXT WHITE LEV.   2
- TXT INVERS       OFF
- TXT FINE POS.    2

- EXIT
    
```

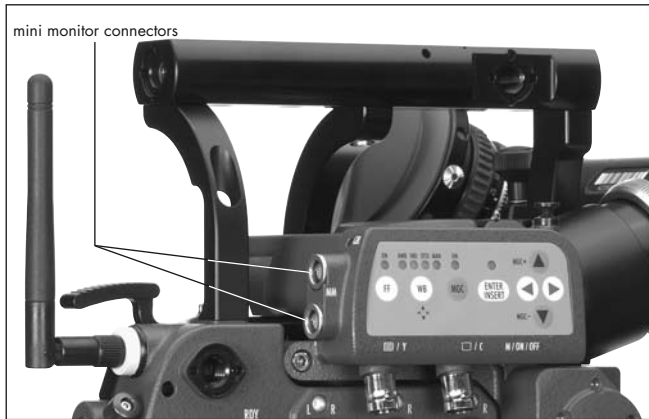

Mini-Monitor Outputs

The IVS has two mini-monitor connectors. Typically one might be used for a standard mini-monitor and the other for a video transmitter.

It is possible to switch between normal video and video with data on the Mini-Monitor output.

- To switch between normal video and video with data on the mini monitor outputs, use the on-screen program mode. Enter the main menu by pressing the Enter/Insert key  for more than 3 seconds. Go to sub menu VIDEO/TEXT ADJUST. The menu line MINI MON DATA can be switched OFF and ON. See chapter 10.4 Inserter Facilities for information on the on-screen program mode.

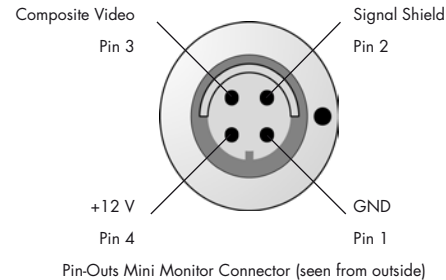

Note: Maximum combined output for the Mini-Monitor connectors is 3 A (36 W).

10.3 Standard Video Controls

The IVS can be used as a standard video assist if no inserter features are used.

Note: All currently used settings are stored even when the IVS or the camera is switched off. After restarting the IVS the settings are unchanged, except for the image stored mode, which will always come up in live mode and the color bars, which will always be switched off.

10.3.1 Switch On, Off and Check/Hide Menu

The IVS can be switched on and off independently from the film camera, as long as the film camera is switched on. Turning off the film camera will also turn off the IVS. The Check/Hide Menu position has a spring return so it will return to the ON position when it is released ⇒ **photo**.

- The OFF position switches the IVS off without affecting the film camera. ON activates the IVS.

Check Menu

If the on-screen program mode is off during normal operation, the Menu (M) position shows an overview of the IVS settings ⇒ **photo**.

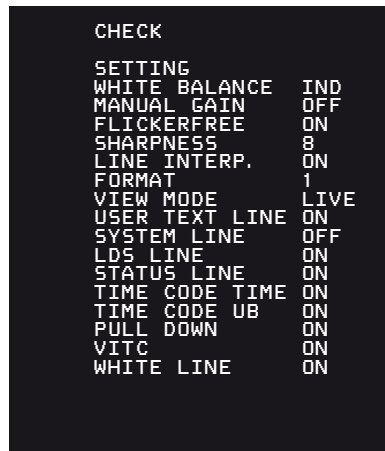
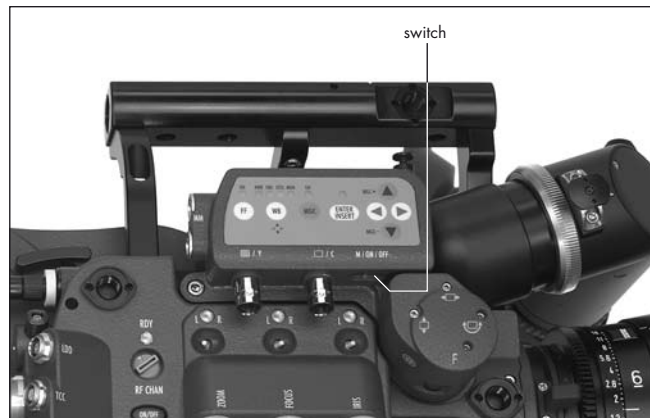



Hide Menu

If the on-screen program mode is on because the settings are changed, the Menu (M) position clears the screen. For example, if color is to be changed with the on-screen program tool, the on-screen program window overlays the image. To see the image and check its color appearance, go to M position. The window disappears but the on-screen program mode is still on. By releasing the switch, the window will come back in the programming mode.

10.3.2 Mechanical Iris

Only a relatively small portion of the light that passes through the film camera's lens reaches the CCD chip of the video assist, because the light is shared between the view finder, the CCD Chip and the film. Therefore, the IVS lens is designed for normal use with a totally open iris so the maximum amount of light falls on the CCD Chip. Variations in lighting are compensated by the IVS gain control (automatically or manually).

Under certain conditions, such as when lighting is set for low sensitivity film (under 100 ASA), it may be that the IVS gain range is exceeded. In this case the mechanical iris of the IVS lens can be closed.



Check all settings on a correctly adjusted monitor.

If the mechanical iris is closed more than necessary, the IVS will compensate by increasing the gain and restore the image brightness electronically. This creates additional electronic noise. To avoid this, open the mechanical iris.

- To change the iris, turn the wheel with the iris symbol .



10.3.3 Alignment of the image position (X, Y and Rotation) and focus

The position of the image on the CCD Chip and its focus can vary slightly from camera to camera. The video image on the monitor may appear off-centre, not levelled or out of focus.

All adjustments can be made by using a 1,5 mm Allen key, which is delivered with the IVS.



Do not use force!

- Image position adjustments in x and y direction can be made with the adjustment screws marked x and y ⇒ **photo**.
- The screw marked  moves the video image horizontally on the monitor. The screw marked  moves it vertically.

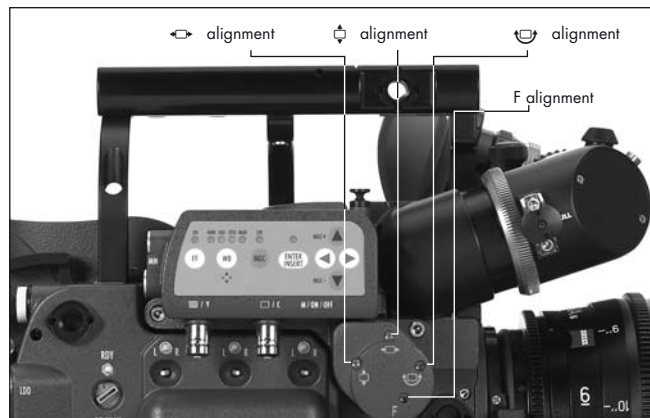

Note: Design restrictions imposed by the IVS' small size mean that the direction of movement imparted by the x and y adjustment screws might be not precisely in the x and y directions.

- Image rotation can be adjusted by the screw marked with the  symbol ⇒ **photo**.
- The image can be focussed using the screw which is marked with the F symbol ⇒ **photo**.

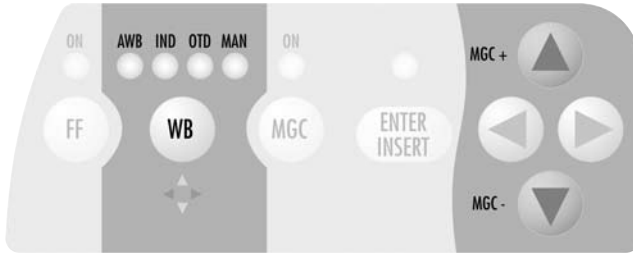

10.3.4 White Balance (WB)

The IVS offers a choice of White Balance methods between









- automatic control (AWB)
- fixed setting of indoor (IND)
- fixed setting for outdoor (OTD)
- a one push white setting procedure
- and a full manual control of white balance (MAN).

White balance can be manually adjusted in two different ways: Either with the keypad on the IVS or by using the on-screen control menu.

Using the Keypad



Check all settings on a correctly adjusted monitor.

- By pressing the WB key  ⇒ **photo**, the setting will be changed from AWB, IND, OTD to MAN. The LED corresponding to the selected setting will light. After MAN, the next click on the WB key  will cause the MAN LED to blink.
- It is now possible to manually change the red and blue channels or to use the one push white facility. To change manually, make sure that the MAN LED flashes and use the color coded , ,  and  keys. The next click on the WB key  or waiting longer than 5 seconds without pressing any key will cause the MAN LED to be constantly on.
For the one push white mode, point the film camera at a white surface, e.g. a sheet of paper in front of the camera, and make sure that the MAN LED and the Enter Insert LED are flashing. Then press the  key. Another click on the WB key  will lead back to AWB. An illuminated LED shows the selected mode.
- If Automatic White Balance (AWB) is selected, the IVS will automatically set the White Balance. No manual steps are necessary in this mode ⇒ **photo**.
- If indoor (IND) is selected ⇒ **photo** white balance is optimized for tungsten lighting with a color temperature of 3200 K.
- The outdoor (OTD) setting ⇒ **photo** optimizes the white balance for daylight with a color temperature of 5600 K.

Note: With the MAN LED constantly on, no color settings can be made to avoid accidental adjustment.

Note: The one push white facility is only available when the exposure is within the normal range. If the image is over or underexposed, one push white will not work.

Note: Changing red, blue and gain will also change green. The video signal is the addition of red, green and blue and amplified by the gain. Decreasing red and blue and lifting gain increases green.







```
MENU WB/GAIN/BARS
-> - WHITE BALANCE  IND
    AUTOADJUST
      RED
      BLUE
  - MANUAL GAIN    OFF
    VALUE
  - COLOR BARS    OFF
  - EXIT
```

```
MENU WB/GAIN/BARS
-> - WHITE BALANCE  MAN
    AUTOADJUST
      RED           30
      BLUE          39
  - MANUAL GAIN    OFF
    VALUE
  - COLOR BARS    OFF
  - EXIT
```

Using the on-screen menu

Please see chapter 10.4 Inserter Facilities for basics on the On-screen display.

As well as control by the keypad, white balance can also be programmed via the on-screen menu.

- Enter the main menu by pressing the Enter/Insert key  for more than 3 seconds.
Go to sub menu WB/GAIN/BARS.
Move the cursor  with the keys  and  to the line - WHITE BALANCE. Pressing the key  will switch from Automatic White Balance (AWB), Indoor (IND) and Outdoor (OTD) to Manual (MAN) and back Automatic White Balance. The  key scrolls through the options in the opposite direction.
- When white balance is set to manual, the display changes: Lines to the left of AUTOADJUST, RED and BLUE appear, indicating that the one push white facility is available or red and blue saturation of the video image can now be changed.

One push white



One push white is only available when white balance control is set to manual.

If manual white balance is set to MAN, it is possible to use the one push white facility or to adjust the red and blue saturation of the video image manually.

- Move the cursor \rightarrow with the keys \uparrow and \downarrow to the line - AUTOADJUST. Point with the camera to a white surface. e.g. hold a sheet of paper in front of the camera. Press the \rightarrow key to start the one push white facility, thus adjusting the white balance to the white in front of the camera.

The LEDs in the keypad will follow the changes which are made in this menu and vice versa, if the setting is changed via the keypad, the on-screen menu will follow.

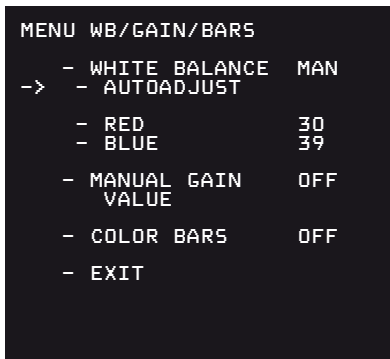

```
MENU WB/GAIN/BARS
- WHITE BALANCE MAN
- AUTOADJUST
-> - RED 30
- BLUE 39
- MANUAL GAIN OFF
  VALUE
- COLOR BARS OFF
- EXIT
```

Manual White Balance red increase/decrease



Manual white balance red increase/decrease is only available if white balance control is set to manual.

When manual white balance is on MAN, it is possible to use the one push white facility or to adjust the red and blue saturation of the video image manually.

- Move the cursor \rightarrow with the keys \uparrow and \downarrow to align with - RED. Pressing the \rightarrow key will increase the red in the video image; pressing the \leftarrow key will decrease it.

The range for this is from 0 (lowest) to 63 (highest).

- If the key \rightarrow or \leftarrow is pressed briefly, the value changes by one step, if the keys are held pressed longer, the value will continue to change.

The LED in the keypad will follow the changes which are made in this menu and vice versa, if this setting is changed via the keypad, the on-screen menu will follow.

Manual White Balance blue increase/decrease



Manual white balance blue increase/decrease is only available if white balance control is on manual.

If manual white balance is on MAN, it is possible to use the one push white facility or to adjust the red and blue saturation of the video image manually.

- Move the cursor \rightarrow with the keys \uparrow and \downarrow to align with – BLUE. Pressing the \rightarrow key will increase the red in the video image; pressing the \leftarrow key will decrease it.

The range for this is from 0 (lowest) to 63 (highest).

- If the key \rightarrow or \leftarrow is pressed briefly, the value changes by one step, if the keys are held pressed longer, the value will continue to change.

The LED in the keypad will follow the changes which are made in this menu and vice versa, if this setting is changed via the keypad, the on-screen menu will follow.

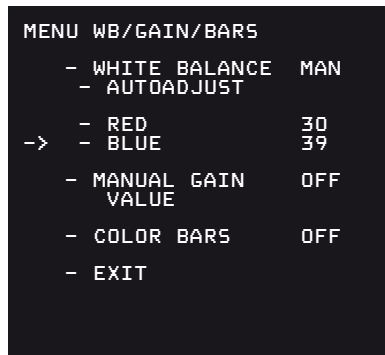

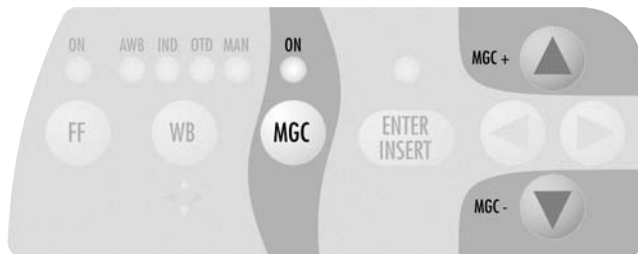

10.3.5 Gain Control

The gain control of the IVS can be set to automatic or manual. When set to automatic, the brightness of the video image is adjusted electronically.



If automatic control is selected, the IVS outputs the best possible image brightness at all times. Light changes in front of the film camera are compensated by the IVS and the brightness appears almost unchanged.

Gain control can be adjusted in two different ways. It is possible to control it either using the keypad on the IVS or by using the on-screen control menu.

Using the Keypad



Check all settings on a correctly adjusted monitor.

- By pressing the MGC key  the setting alters between manual and automatic control. An LED above the MGC key lights when manual gain control (MGC) is selected ⇒ **photo**.
- If manual gain control is selected (LED is on), the brightness of the video image can be manually altered. By using the  or  key brightness can be increased or decreased. The automatic compensation of different light levels in front of the camera is suppressed.

Using the on-screen menu

Please see chapter 10.4 Inserter Facilities for basics on the On-Screen display.

The manual gain control can be programmed via the on-screen menu as well as control via keypad,. Manual gain control can be switched on or off. If it is on, values can be set between 0 (low gain) and 63 (high gain).

- Enter the main menu by pressing the Enter/Insert key



for more than 3 seconds.

Go to sub menu WB/GAIN/COLOR BARS. Move the cursor ➤ with the keys ▲ and ▼ to the line – MANUAL GAIN. Pressing the key ► or ◀ will switch manual gain control off and on. If manual gain control is on, the display will change. A line symbol – appears before VALUE indicating that the gain can be changed manually.

The LED in the keypad will follow the changes which are made in this menu and vice versa, if this setting is changed via the keypad, the on-screen menu will follow.

```

MENU WB/GAIN/BARS
  - WHITE BALANCE  MAN
  - AUTOADJUST
    - RED          30
    - BLUE         39
-> - MANUAL GAIN   OFF
    VALUE
  - COLOR BARS    OFF
  - EXIT
  
```

```

MENU WB/GAIN/BARS
  - WHITE BALANCE  MAN
  - AUTOADJUST
    - RED          30
    - BLUE         39
-> - MANUAL GAIN   ON
    VALUE         40
  - COLOR BARS    OFF
  - EXIT
  
```

```
MENU WB/GAIN/BARS
- WHITE BALANCE  MAN
- AUTOADJUST
- RED            30
- BLUE          39
-> - MANUAL GAIN  ON
- VALUE        40
- COLOR BARS    OFF
- EXIT
```

Manual Gain increase/decrease



Manual gain increase/decrease is only available when manual gain control is on.

- Move the cursor \rightarrow with the keys \uparrow and \downarrow to the line - VALUE. Pressing the key \rightarrow will increase the gain; the key \leftarrow will decrease it.

The range for this is from 0 (lowest gain) to 63 (highest gain).

- If the key \rightarrow or \leftarrow is pressed briefly, the value changes by one step, if the keys are held pressed longer, the value will continue to change.

The LED in the keypad will follow the changes which are made in this menu and vice versa, if this setting is changed via the keypad, the on-screen menu will follow.

10.3.6 Flicker free on/off

Flicker free can be switched off to bypass the digital frame store and have the video assist output with no delay.

The typical running speed for the film camera is different to that of the video assist. e.g. the film camera runs at 24 fps and the video assist at 25 fps for PAL or 30 fps for NTSC. Without flicker processing this speed difference causes varying brightness between successive individual video images. To eliminate this so called flicker, video images are stored at the speed of the film camera into the video frame storage and recalled in the speed of the video system. This storage might cause a slight delay, which is not desirable in some time-crucial conditions, e.g. motion control or shooting of a pop video. Therefore it is possible to switch the flicker free system off. This will eliminate the delay. However, flicker will occur in this mode.

Using the Keypad

- By pressing the FF key (Ⓢ) the flicker free mode alters between on and off. An LED illuminates to show flicker free (FF) is set to on ⇒ **photo**.









```
MENU VIDEO/TEXT ADJUST
-> - FLICKERFREE      ON
    - LINE INTERP.   ON
    - SHARPNESS      2
    - BNC OUT        VBS
    - Y/C DATA
    - GENLOCK        OFF
    - MINI MON DATA ON
    -
    - TXT WHITE LEV. 2
    - TXT INVERS     OFF
    - TXT FINE POS.  2
    -
    - EXIT
```

Using the on-screen menu

Please see chapter 10.4 Inserter Facilities for basics on the On-Screen display.

Flicker free off can also be programmed via the on-screen menu as well as via the keypad.

- Enter the main menu by pressing the Enter/Insert key  for more than 3 seconds. Go to sub menu VIDEO/TEXT ADJUST. Move the cursor  with the keys  and  to the line- FLICKERFREE. Pressing the key  or  will switch flicker free mode off and on.

Note: The lowest camera speed for flicker free display is 5 fps in automatic gain control mode and 1 fps in manual gain control mode.

10.3.7 Changing Format marking number

The IVS can insert different format markings. It is possible to have

- no format marking (OFF),
- format marking number one (1),
- format marking number two (2)
- or both format markings at the same time (1 & 2) on display.

Using the Keypad



The adjustment of the different format markings can only be done via the on-screen display as described in chapter 10.4.6 Format Marking Menu. However, it is possible to select which format markings are displayed via the keypad.

The format marking selection is only possible when the White Balance manual mode is not active (when the WB MAN LED is not flashing). If white balance manual mode is active, please wait for more than 5 seconds without pressing any key to leave this mode.

- The key  will switch from OFF, 1, 2 to 1&2. The key  will switch in the opposite order.









```
MENU FORMAT MARKING
-> - FORMAT          OFF
    POSITION 1      F
    POSITION 1      F
    POSITION 2      F
    POSITION 2      F
    WHITE LEVEL
    OUTSIDE
- EXIT
```

Using the on-screen menu

Please see chapter 10.4 Inserter Facilities for basics on the On-Screen display.



The format marking number can be programmed via the on-screen menu as well as via the keypad.

- Enter the main menu by pressing the Enter/Insert key  for more than 3 seconds.
Go to sub menu FORMAT MARKING. Move the cursor  with the keys  and  to the line - FORMAT. Pressing the key  will switch from OFF, 1, 2 to 1&2. The key  will switch in the opposite order.

10.3.8 Storing a video image

The IVS can grab and store a selected image, display that or overlay it against the live image in front of the camera to compare both images. Although the options to display the stored image and to compare the stored image against the live image are only available in the on-screen program mode, it is possible to store an image any time using the Enter/Insert key .

Using the Keypad







- Pressing the Enter/Insert key  briefly (less than 1.5 seconds) will store an image in the frame store.
- Every time the Enter/Insert key  is briefly pressed, a new image is stored.
- To view the stored image, or to compare it against a live image, please enter the on-screen program mode, as described in chapter 10.4.7 Display mode



```
MENU COMPARE/STORE
- VIEW MODE      LIVE
-> - STORE IMAGE
  - CLEAR IMAGE
- EXIT
```

Using the on-screen menu

Please see chapter 10.4 Inserter Facilities for basics on the On-Screen display.

- Enter the main menu by pressing the Enter/Insert key  for more than 3 seconds.
Go to sub menu COMPARE/STORE. Move the cursor  with the keys  and  to the line - STORE IMAGE. Pressing the key  or  will store the image. The word **DONE** will appear for a few seconds to show that an image was stored.

The stored image is memorized until a new image is stored, the image is cleared or until the IVS is turned off.

10.3.9 Wrong Cable Warning LED

The main reason for damage to the IVS is incorrectly wired cables connected to any of the IVS outputs. Even if some faults do not cause immediate destruction, they put the IVS at risk and may eventually cause failures of the IVS unit. Therefore the IVS checks for the following wrong conditions on the outputs:

- Bridge between camera power supply ground and video signal ground (e.g. shield of BNC sockets)
- Bridge between positive camera power supply and video signal ground (e.g. shield of BNC sockets)
- Bridge between positive camera power supply and housing of the camera and/or IVS
- AC between camera power supply and video signal ground (e.g. shield of BNC sockets)
- AC between camera power supply and housing of the camera and/or IVS
- AC between housing of the camera/IVS and video signal ground (e.g. shield of BNC sockets)

If one of the above described conditions is detected, the Cable Warning LED (CBL) will light up. Disconnect all cables from the IVS and/or ARRIFLEX 416 until the warning disappears. Do not use the faulty cable again.

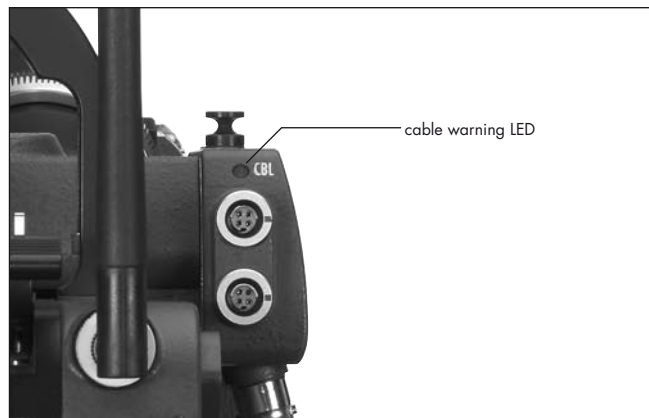

Note: The above mentioned faults are caused by 3rd party cables, improper cables, faulty cables or a fault condition on equipment connected to these cables. Please report such conditions immediately to the camera owner.

10.4 Inserter Facilities

In addition to the usual video assist functions, the IVS offers a variety of inserter facilities. They fall into three different groups of information:

- Format markings
 - Format markings, which are inserted electronically, are often more visible than the format markings on the fibre screen.
- Man Readable Information
 - Camera status
 - System line
 - Lens Data Information
 - Timecode
 - User Bits
 - Pull Down Information
 - Additional text
- Machine Readable Information
 - VITC
 - White Line Flag



*Inserted data is only available on outputs that have video with data.
Engravings from the fibre screen (e. g. TV Safe etc.) are visible at all times on all outputs.*





















Note: All currently used settings are stored even if the IVS or the camera is switched off or disconnected from the power supply. After restarting the IVS the settings remain unchanged, except for the image stored mode, which will always come up in live mode and the color bars, which will always be switched off.





10.4.1 Setting the On-Screen Displays



During programming, inserted data is not fully updated (e.g. Frame Counter Information). To get updated information, leave the on-screen display menu by pressing the Enter/Insert key  for more than three seconds.

Once the on-screen display is activated by pressing the Enter/Insert key  for more than three seconds, the following procedure is used to select and set all functions within the main menu and the sub menus:

- Pressing the key  or  will move the cursor  up or down. Pressing the key  or  activates sub menus.
- Within sub menus the cursor  can be moved up and down again by pressing the key  or . The keys  or  will now change settings (e. g. switch the insertion of a user text window on and off), or activates functions (position mode of a window or EXIT).
- If the windows position mode is activated, the keys  or  will move the window across the video image. To leave the position mode press the Enter/Insert key  briefly.
- To go from a sub menu back to the main menu, position the cursor  by using the keys  and  on the line EXIT and press the key  or .

- Active lines are marked with a dash symbol –. They can be reached with the cursor  within a menu using the keys  and . Lines may be visible but without a dash because the currently selected mode does not use this feature. E.g. when gain is not in manual control mode, the line value is not active because value cannot be changed in the automatic control mode. In this case, no dash symbol – is displayed and the line cannot be reached with the cursor . To activate this line, switch from automatic to manual gain control mode.





Note:





Changes made to settings are immediately activated.

Pressing the Enter/Insert key  for more than three seconds will cause the system to exit the on-screen programming mode completely, regardless of which menu is activated, with the exception of the positioning mode.

10.4.2 Main Menu

The inserter's main menu is displayed on the monitor screen when the on-screen programming is activated by pressing the Enter/Insert key  ⇒ **photo** for more than three seconds. An illuminated LED indicates that the on-screen programming is activated.

Note: Pressing the Enter/Insert key  for more than three seconds will cause the system to exit the on-screen programming mode completely, regardless of which menu is activated, with the exception of the positioning mode.

- The keys  or  move the cursor  up or down. Pressing the key  or  will lead into a sub menu.

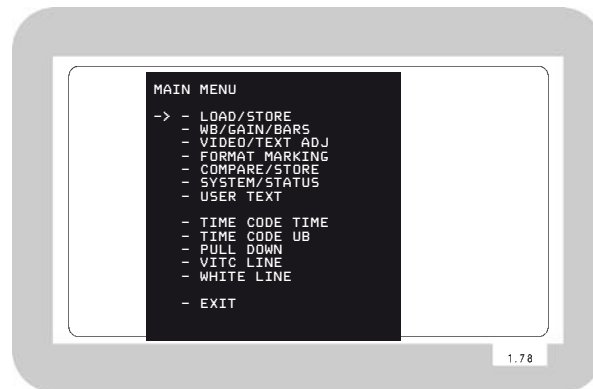

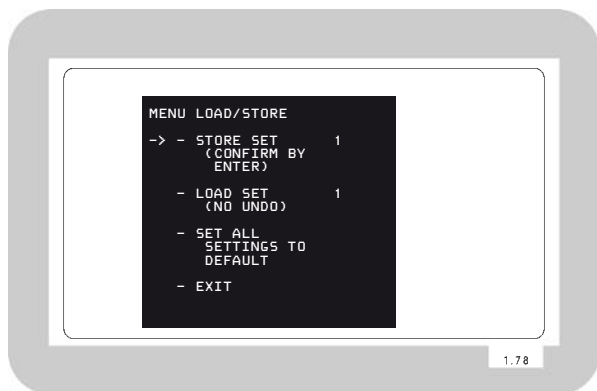

10.4.3 Load/Store Menu

The IVS can store up to 5 sets of settings and recall them. The default values are a 6th set of settings. Thus it is possible to make all settings for e.g. indoor shooting and store them as setting 1. Shooting continues with some exterior scenes and the operator will make all settings for this and store them as setting 2. When the work is continued indoors, it is very easy to recall all the settings stored as setting 1 and get the same image appearance as before.

A set of settings consists of all set-ups in the IVS. Everything which can be set electronically, will be stored and recalled. All video adjustments such as manual gain control, white balance, flicker free, outputs with or without data and line interpolation as well as all inserter setups, e.g. user text insertion off or on, frame lines and so on are stored and recalled.

The adjustment of the white level of the inserted data, an inverse display and a fine adjustment of the vertical position is described in chapters 10.4.5 White Level, Inverse and Fine Positioning.









Changes made to settings are immediately activated. Check all settings on a correctly adjusted monitor.

- Enter the Load/Store submenu from the main menu.

Store Settings

The set of settings, that are currently active, can be stored as one out of five settings.

- Move the cursor  with the  and  keys to the line – STORE SET. Pressing the  key will switch from 1 to 2 all the way up to 5 and then back to 1, the  key will step in the opposite direction.

- When the required number is reached, press the Enter/Insert key  to store this setting under the given number. The word **DONE** will appear for 3 seconds to indicate that the setting was stored. After this, the display will return to its normal mode.









The new set of settings will immediately replace the old set of settings. The old settings can not be recalled.

Load Settings

It is possible to load one out of five settings. The new settings will influence all adjustments that can be made electronically.



The new settings will immediately replace the previous settings. If the old settings might be needed again, store them first as described in the previous chapter Store Settings.

- Move the cursor  with the  and  keys to the line – LOAD SET. Pressing the  key will switch from 1 to 2 all the way up to 5 and back to 1, the  key will switch in the opposite direction. Pressing either the  or  keys will immediately load the new settings.

```
MENU LOAD/STORE
-> - STORE SET          1
      (CONFIRM BY
      ENTER)

- LOAD SET            1
  (NO UNDO)

- SET ALL
  SETTINGS TO
  DEFAULT

- EXIT
```

```
MENU LOAD/STORE

- STORE SET          1
  (CONFIRM BY
  ENTER)

-> - LOAD SET          1
      (NO UNDO)

- SET ALL
  SETTINGS TO
  DEFAULT

- EXIT
```

```

MENU LOAD/STORE
- STORE SET          1
  (CONFIRM BY
  ENTER)
- LOAD SET          1
  (NO UNDO)
-> - SET ALL
    SETTINGS TO
    DEFAULT
- EXIT
  
```

```

ARE YOU SURE?
(NO UNDO)
-> - NO
- YES
- EXIT
  
```

All Settings to Default



When the function set all settings to default is called, all settings are cleared. They cannot be recalled.

This menu recalls default setting for all values. This makes it possible to obtain basic setting throughout the IVS.

- Move the cursor \blacktriangleright with the keys \uparrow and \downarrow to the line – SET ALL. Pressing the key \rightarrow or \leftarrow recalls the default values and overwrites all stored settings.
- It is necessary to confirm this procedure, as all settings will be cleared. This window will appear with the cursor \blacktriangleright in the line NO. Pressing the key \rightarrow or \leftarrow will cancel the procedure.
- To clear everything, move the cursor \blacktriangleright with the keys \uparrow and \downarrow to the line – YES. Pressing the key \rightarrow or \leftarrow sets all settings to default.
- If the cursor \blacktriangleright is in position EXIT and the key \rightarrow or \leftarrow is pressed, the IVS will return to the Load/Store menu without setting everything to default.

The default values are:

WB = INDOOR

Manual Gain with GAIN = 0

FLICKER FREE = ON

LINE INTERPOLATION = ON

Y/C data = ON
BNC OUT = VBS
MINI-MONITOR DATA = ON
GENLOCK = OFF
FORMAT 1 = ON
FORMAT 2 = OFF
WHITE LEVEL frame lines = 2
COLOR BARS = OFF
OUTSIDE area = DARK
VIEW MODE = LIVE (Frame store is cleared)
SYSTEM LINE = ON
LDS LINE = OFF
STATUS LINE = ON
TIMECODE TIME window = ON
TIMECODE UB window = OFF
PULL DOWN window = OFF
VITC = OFF
WHITE LINE = OFF
BACKGROUND status/system = BOXED
FILM COUNTER on set to FOOTAGE
USER TEXT LINE = OFF
BACKGROUND User Text line = BOXED
SIZE = SMALL
WHITE LEVEL TEXT = 2
INVERSE = OFF
VERT POS = 5
SHARPNESS = 1

```
MENU LOAD/STORE
- STORE SET          1
  (CONFIRM BY
  ENTER)
- LOAD SET          1
  (NO UNDO)
- SET ALL
  SETTINGS TO
  DEFAULT
-> - EXIT
```

Exit

Use exit to return to the main menu.

- Move the cursor \rightarrow with the keys \uparrow and \downarrow to the line -EXIT and press the key \rightarrow or \leftarrow .

Note: Pressing the Enter/Insert key $\text{\textcircled{ENTER/INSERT}}$ for more than three seconds will cause the system to exit the on-screen programming mode completely, regardless of which menu is activated, with the exception of the positioning mode.

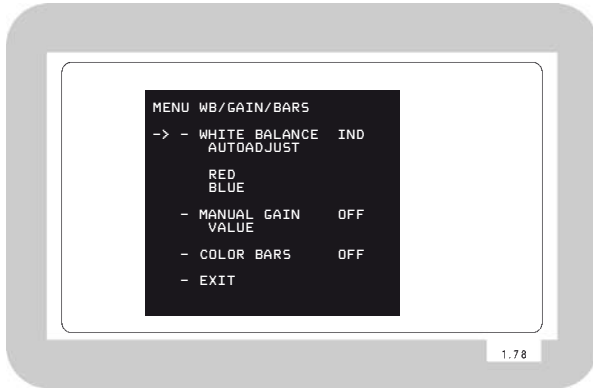

10.4.4 White Balance (WB), Manual Gain Control (MGC) and Bars Menu

White balance and manual gain control allows the user to change the color appearance and brightness of the video image. Color Bars help to set up and test connected monitors.



*Changes made to settings are immediately activated.
Check all settings on a correctly adjusted monitor.*

- Enter the WB/Gain/Bars submenu from the main menu.

White Balance (Indoor/Outdoor/Automatic/Manual)

White balance can be programmed via the on-screen menu as well as via the keypad. It toggles through Indoor, Outdoor and Automatic and Manual.

- Move the cursor \rightarrow with the keys \uparrow and \downarrow to the line - WHITE BALANCE. Pressing the key \rightarrow will switch from Automatic White Balance (AWB), Indoor (IND) and Outdoor (OTD) to Manual (MAN) and back to Automatic White Balance. The key \leftarrow will step in the opposite direction.
- If white balance is set on manual, the display options will change: Lines left of AUTOADJUST; RED and BLUE will appear indicating that the one push white facility is available or red and blue saturation of the video image can now be changed.

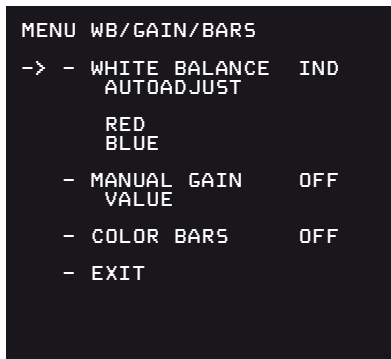

MENU	WB/GAIN/BARS	
->	- WHITE BALANCE	MAN
	- AUTOADJUST	
	- RED	30
	- BLUE	39
	- MANUAL GAIN	OFF
	VALUE	
	- COLOR BARS	OFF
	- EXIT	

One push white



One push white is only available when the white balance control is on manual.

If manual white balance is on MAN, it is possible to use the one push white facility or to adjust the red and blue saturation of the video image manually.

- Move the cursor \rightarrow with the keys \uparrow and \downarrow to the line - AUTOADJUST. Point the camera at a white surface. e.g. hold a sheet of paper in front of the camera. Press the key \rightarrow to start the one push white facility, thus adopting the white balance to the sample white in front of the camera.

The LED in the keypad will follow the changes which are made in this menu and vice versa, if this setting is changed via the keypad, the on-screen menu will follow. The automatically derived values are displayed in the RED and BLUE line.

Manual White Balance red increase/decrease



Manual white balance red increase/decrease is only available if white balance control is on manual.

If manual white balance is on MAN, it is possible to use the one push white facility or to adjust the red and blue saturation of the video image manually.

- Move the cursor ➤ with the keys ▲ and ▼ to the line – RED. Pressing the key ▶ will increase the red in the video image; the key ◀ will decrease it. The range for this is from 0 (lowest) to 63 (highest).
- If the key ▶ or ◀ is pressed briefly, the value is changes by one step, if the keys are pressed longer, the value will continue to change.

The LED in the keypad will follow the changes which are made in this menu and vice versa, if this setting is changed via the keypad, the on-screen menu will follow.

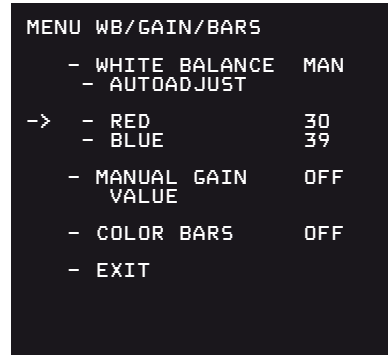

MENU WB/GAIN/BARS		
-	WHITE BALANCE	MAN
-	AUTOADJUST	
->	RED	30
	BLUE	39
-	MANUAL GAIN VALUE	OFF
-	COLOR BARS	OFF
-	EXIT	

Manual White Balance blue increase/decrease



Manual white balance blue increase/decrease is only available if white balance control is on manual.

If manual white balance is on MAN, it is possible to use the one push white facility or to adjust the red and blue saturation of the video image manually.

- Move the cursor \rightarrow with the keys \uparrow and \downarrow to the line - BLUE. Pressing the key \rightarrow will increase the blue in the video image; the key \leftarrow will decrease it. The range for this is from 0 (lowest) to 63 (highest).
- If the key \rightarrow or \leftarrow is pressed briefly, the value is changes by one step, if the keys are pressed longer, the value will continue to change.

The LED in the keypad will follow the changes which are made in this menu and vice versa, if this setting is changed via the keypad, the on-screen menu will follow.

Manual Gain Control ON/OFF

The manual gain control can be programmed via the on-screen menu as well as via the keypad. Manual gain control can be switched on or off. If it is on, specific values can be set between 0 (low gain) and 63 (high gain). If it is off, automatic mode is active.

- Move the cursor \rightarrow with the keys \uparrow and \downarrow to the line – MANUAL GAIN. Pressing the key \rightarrow or \leftarrow will switch manual gain control off and on. If manual gain control is on, the display will change. A line symbol – will appear before VALUE indicating that the gain can be changes manually.

The LED in the keypad will follow the changes which are made in this menu and vice versa, if this setting is changed via the keypad, the on-screen menu will follow.

```
MENU WB/GAIN/BARS
  - WHITE BALANCE  MAN
  - AUTOADJUST
    - RED          30
    - BLUE         39
-> - MANUAL GAIN  OFF
    VALUE
  - COLOR BARS    OFF
  - EXIT
```

```
MENU WB/GAIN/BARS
  - WHITE BALANCE  MAN
  - AUTOADJUST
    - RED          30
    - BLUE         39
-> - MANUAL GAIN  ON
    VALUE         40
  - COLOR BARS    OFF
  - EXIT
```

```
MENU WB/GAIN/BARS
- WHITE BALANCE  MAN
- AUTOADJUST
- RED            30
- BLUE          39
-> - MANUAL GAIN  ON
- VALUE         40
- COLOR BARS    OFF
- EXIT
```

Manual Gain increase/decrease



Manual gain increase/decrease is only available when manual gain control is on.

If manual gain is on, it is possible to adjust the gain manually.

- Move the cursor \rightarrow with the keys \uparrow and \downarrow to the line - VALUE. Pressing the key \rightarrow will increase the gain; the key \leftarrow will decrease it. The range for this is from 0 (lowest gain) to 63 (highest gain).
- If the key \rightarrow or \leftarrow is pressed briefly, the value is changes by one step, if the keys are pressed longer, the value will continue to change.

The LED in the keypad will follow the changes which are made in this menu and vice versa, if this setting is changed via the keypad, the on-screen menu will follow.

Color Bars ON/OFF

Color bars can be displayed instead of the video image. The bars are helpful to set up or check monitors, which are connected to the IVS.

Note: If the IVS is switched off and on again, it will always start in the mode COLOR BARS OFF to avoid accidental use of this mode.

- Move the cursor \blacktriangleright with the keys \blacktriangle and \blacktriangledown to the line – COLOR BARS. Pressing the \blacktriangleright or \blacktriangleleft key will switch the color bars on and off.

Exit

Use exit to return to the main menu.

- Move the cursor \blacktriangleright with the keys \blacktriangle and \blacktriangledown to the line – EXIT and press the key \blacktriangleright or \blacktriangleleft .

Note: Pressing the Enter/Insert key $\text{\textcircled{ENTER/INSERT}}$ for more than three seconds will cause the system to exit the on-screen programming mode completely, regardless of which menu is activated, with the exception of the positioning mode.

```
MENU WB/GAIN/BARS
- WHITE BALANCE  MAN
- AUTOADJUST
- RED            30
- BLUE          39
- MANUAL GAIN   OFF
  VALUE
-> - COLOR BARS  OFF
- EXIT
```

```
MENU WB/GAIN/BARS
- WHITE BALANCE  MAN
- AUTOADJUST
- RED            30
- BLUE          39
- MANUAL GAIN   OFF
  VALUE
-> - COLOR BARS  OFF
- EXIT
```

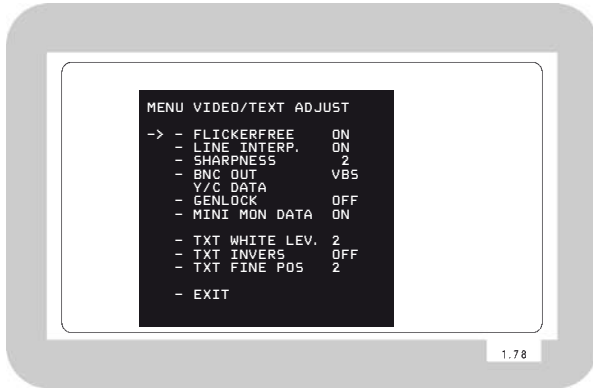

10.4.5 Video and Text Adjustment Menu

This sub menu allows the user to change basic video settings as well as the appearance of the inserted man readable text.



*Changes made to settings are immediately activated.
Check all settings on a correctly adjusted monitor.*

- Enter the Video/Text Adjust submenu from the main menu.

Flicker free ON/OFF

Flicker free can be switched off to bypass the digital frame store and have the video assist output with no delay.

The typical running speed for the film camera is different to that of the video assist. e.g. the film camera runs at 24 fps and the video assist at 25 fps for PAL or 30 fps for NTSC. Without flicker processing this speed difference causes varying brightness between successive individual video images. To eliminate this so called flicker, video images are stored at the speed of the film camera into the video frame storage and recalled in the speed of the video system. This storage might cause a slight delay, which is not desirable in some time-crucial conditions, e.g. motion control or shooting of a pop video. Therefore it is possible to switch the flicker free system off. This will eliminate the delay. However, flicker will occur in this mode.

In parallel to the control via keypad, the flicker free off can also be programmed via the on-screen menu.

- Move the cursor ➤ with the keys ▲ and ▼ to the line – FLICKERFREE. Pressing the key ► or ◀ will switch flicker free mode off and on.

Note:

The lowest camera speed for flicker free display is 5 fps in automatic gain control mode and 1 fps in manual gain control mode.

```

MENU VIDEO/TEXT ADJUST
-> - FLICKERFREE      ON
    - LINE INTERP.   ON
    - SHARPNESS      2
    - BNC OUT        VBS
    - Y/C DATA
    - GENLOCK        OFF
    - MINI MON DATA ON

    - TXT WHITE LEV. 2
    - TXT INVERS     OFF
    - TXT FINE POS   2

    - EXIT
  
```

MENU VIDEO/TEXT ADJUST

```
- FLICKERFREE      ON
-> - LINE INTERP.   ON
- SHARPNESS        2
- BNC OUT          VBS
- Y/C DATA
- GENLOCK          OFF
- MINI MON DATA  ON

- TXT WHITE LEV.   2
- TXT INVERS       OFF
- TXT FINE POS     2

- EXIT
```

MENU VIDEO/TEXT ADJUST

```
- FLICKERFREE      ON
-> - LINE INTERP.   ON
- SHARPNESS        2
- BNC OUT          VBS
- Y/C DATA
- GENLOCK          OFF
- MINI MON DATA  ON

- TXT WHITE LEV.   2
- TXT INVERS       OFF
- TXT FINE POS     2

- EXIT
```

Line interpolation on/off

Due to the rotating mirror shutter of the film camera, the CCD chip of the IVS gets light only for 50 % of the time. All video assists will therefore have only one true video field and the next one will be the repetition of the previous one. So the repeated video field does not have new information. To improve this situation, the video assist can be electronically enhanced with a feature called line interpolation.

- Move the cursor \rightarrow with the keys \uparrow and \downarrow to the line – LINE INTERP. Pressing the key \rightarrow or \leftarrow will switch the line interpolation on and off.

Note: This setting only affects the video image while the film camera is in run mode.

Sharpness value

The slew rate of the video signal can be electronically adjusted, thus creating a crisper image. However, this will lead to more video artefacts so the best image is a balance between sharpness and video artefacts.

- Move the cursor \rightarrow with the keys \uparrow and \downarrow to the line – SHARPNESS. Pressing the key \rightarrow will switch the sharpness from 0 to 3 and back to 0. The \leftarrow key will give the opposite direction.

Note: Sharpness 1 corresponds to the settings of older IVS types e.g. the IVS 235.

Composite or Y/C signal at the BNC Connectors

The IVS has two BNC sockets which can be switched to output two independent composite signals or one Y/C signal. If selected, the Y/C signal comes from the same BNC connectors on which the composite signal is output.

- Move the cursor \rightarrow with the keys \uparrow and \downarrow to the line – BNC OUT. Pressing the keys \rightarrow or \leftarrow will switch the output signal on the BNC connector between composite (VBS) and Y/C
- If Y/C is selected a line symbol – will appear before Y/C DATA indicating that the Y/C output can now be switched between clean video and video with data.

Y/C signal with or without data

The Y/C signal can be switched between clean video and video with data signals. Whichever option is selected the Y/C signal is output from the same pair of connectors

- Move the cursor \rightarrow with the keys \uparrow and \downarrow to the line – Y/C DATA. Pressing the key \rightarrow or \leftarrow will switch between normal video and video with data in the Y/C signal. The line displays Y/C DATA ON or OFF.

```
MENU VIDEO/TEXT ADJUST
- FLICKERFREE      ON
- LINE INTERP.    ON
- SHARPNESS        2
-> BNC OUT          Y/C
- Y/C DATA        ON
- GENLOCK          OFF
- MINI MON DATA  ON

- TXT WHITE LEV.   2
- TXT INVERS       OFF
- TXT FINE POS     2

- EXIT
```

```
MENU VIDEO/TEXT ADJUST
- FLICKERFREE      ON
- LINE INTERP.    ON
- SHARPNESS        2
-> BNC OUT          Y/C
- Y/C DATA        ON
- GENLOCK          OFF
- MINI MON DATA  ON

- TXT WHITE LEV.   2
- TXT INVERS       OFF
- TXT FINE POS     2

- EXIT
```

```
MENU VIDEO/TEXT ADJUST
- FLICKERFREE      ON
- LINE INTERP.    ON
- SHARPNESS        2
- BNC OUT          VBS
- Y/C DATA
-> - GENLOCK        ON
- MINI MON DATA  ON

- TXT WHITE LEV.   2
- TXT INVERS       OFF
- TXT FINE POS     2

- EXIT
```

GENLOCK on/off

It is possible to synchronize the IVS to an external video signal, thus allowing the user to switch between different video signals without synchronizing problems.

- Connect a standard video signal of the same type as the video system (PAL or NTSC) to the Video output with no data (C-Output).
- Move the cursor \rightarrow with the keys \uparrow and \downarrow to the line – GENLOCK. Pressing the key \rightarrow or \leftarrow will switch genlock ON or OFF.

The video signal out of the connector for video with data is now synchronized to the incoming video signal connected to the other BNC socket.





Note: GENLOCK is only available, if the output is on VBS mode.

Note: This setting is switched back to GENLOCK off after the IVS is started (after power down/power up) to avoid accidental operation.

Mini-Monitor Output as clean video or video with data





The mini monitor output can be programmed to have either clean video or video with data. Both mini monitor outputs are in parallel, so there are either no data, or data on both outputs.

If the on-screen menu control is on (red LED next to the Enter/Insert key  is on), there will always be data in this output. This is necessary because if the output is switched to data off, no inserter information is visible and therefore, it would be impossible to go back into the on-screen menu to change the settings.

- Move the cursor  with the keys  and  to the line – MINI MON DATA. Pressing the key  or  will switch the insertion of data in the mini monitor between ON and OFF.

White Level

This line is used to change the brightness of all man readable windows except the frame lines. Value 0 means dark grey, value 3 corresponds to bright white characters.

- Move the cursor  with the keys  and  to the line – TXT WHITE LEV.. By pressing the key  the values for the brightness of the characters will increment from 0 to 3, and after that back to 0. The key  will decrement in the opposite direction.

```

MENU VIDEO/TEXT ADJUST
- FLICKERFREE      ON
- LINE INTERP.    ON
- SHARPNESS        2
- BNC OUT          Y/C
- Y/C DATA        ON
- GENLOCK          OFF
-> - MINI MON DATA ON

- TXT WHITE LEV.   2
- TXT INVERS       OFF
- TXT FINE POS     2

- EXIT

```

```

MENU VIDEO/TEXT ADJUST
- FLICKERFREE      ON
- LINE INTERP.    ON
- SHARPNESS        2
- BNC OUT          VBS
- Y/C DATA        ON
- GENLOCK          OFF
-> - MINI MON DATA ON

- TXT WHITE LEV.   2
- TXT INVERS       OFF
- TXT FINE POS     2

- EXIT

```

```
MENU VIDEO/TEXT ADJUST
- FLICKERFREE      ON
- LINE INTERP.    ON
- SHARPNESS        2
- BNC OUT          VBS
- Y/C DATA
- GENLOCK          OFF
- MINI MON DATA  ON
- TXT WHITE LEV.  2
-> - TXT INVERS     OFF
- TXT FINE POS    2
- EXIT
```

```
MENU VIDEO/TEXT ADJUST
- FLICKERFREE      ON
- LINE INTERP.    ON
- SHARPNESS        2
- BNC OUT          VBS
- Y/C DATA
- GENLOCK          OFF
- MINI MON DATA  ON
- TXT WHITE LEV.  2
- TXT INVERS     OFF
-> - TXT FINE POS  2
- EXIT
```

Inverse

This menu changes the appearance of all man readable windows. The format markings are not changed. If inverse OFF is selected, the characters will appear white. If the background is BOXED it will appear black in this case. If inverse ON is selected, the characters will appear black. If the background is BOXED it will appear white in this case.

- Move the cursor \rightarrow with the keys \uparrow and \downarrow to the line – INVERSE. The keys \leftarrow or \rightarrow will switch between ON and OFF.

Fine Positioning

By changing the setting in the line Fine Position of this sub-menu it is possible to simultaneously shift all man readable windows vertically by one video line (fine adjust). The single steps are smaller than the steps in the normal position mode. This will place all windows as far outside the actual image area as possible. Format markings are not moved.

- Move the cursor \rightarrow with the keys \uparrow and \downarrow to the line – FINE POS.. By pressing the key \leftarrow the value will increment starting from 0 to 9, after that it will go back to 0. Higher values will cause the windows to be at a higher video line. They will therefore appear lower on the video screen. The key \rightarrow will increment in the opposite direction.

Exit

Use exit to return to the main menu.

- Move the cursor ➤ with the keys ▲ and ▼ to the line -EXIT and press the key ▶ or ◀.

Note: Pressing the Enter/Insert key  for more than three seconds will cause the system to exit the on-screen programming mode completely, regardless of which menu is activated, with the exception of the positioning mode.

```
MENU VIDEO/TEXT ADJUST
- FLICKERFREE      ON
- LINE INTERP.    ON
- SHARPNESS        2
- BNC OUT          VBS
- Y/C DATA
- GENLOCK          OFF
- MINI MON DATA  ON

- TXT WHITE LEV.   2
- TXT INVERS       OFF
- TXT FINE POS     2

-> - EXIT
```



10.4.6 Format Marking Menu

The IVS can insert two different format markings electronically into the video image, either individually or simultaneously. The position of these format markings can be set anywhere on the screen, to line up exactly with the fibre screen markings. The brightness is adjustable in four steps and the area outside of the format markings can be electronically darkened.



*Changes made to settings are immediately activated.
Check all settings on a correctly adjusted monitor.*

- Enter the Format Marking submenu from the main menu.

Activate Format Markings

If the electronic format markings are not parallel to the fibre screen format markings, readjust the CCD chip with the rotation alignment screw, as shown in chapter 10.3.3

Alignment of the image position (X-, Y- and Rotation) and focus.

Note: Only active frame lines can be positioned. If no frame line is on (FORMAT OFF), no position line can be reached with the cursor \rightarrow . If Format 1 is on, only – POSITION 1 can be reached with the cursor \rightarrow . Only if format 1 & 2 is selected, all - POSITION lines can be accessed.

It is possible to have no format marking (OFF), format marking number one (1), format marking number two (2) or both format markings at the same time (1 & 2) on display.

- Move the cursor \rightarrow with the keys \uparrow and \downarrow to the line – FORMAT. Pressing the key \rightarrow will switch from OFF to 1 to 2 to 1 & 2 and back to OFF, the key \leftarrow will switch in the opposite direction.

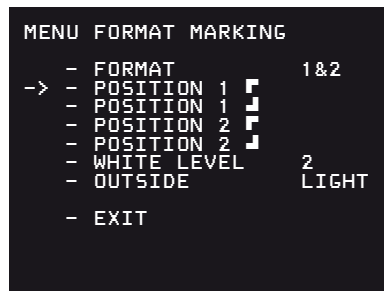

```

MENU FORMAT MARKING
-> - FORMAT                1&2
    - POSITION 1          █
    - POSITION 1          █
    - POSITION 2          █
    - POSITION 2          █
    - WHITE LEVEL        2
    - OUTSIDE            LIGHT
    - EXIT
  
```

Position – Adjusting the position of the Format Markings

The format markings can be adjusted to suit any format. The format markings on the fibre screen serve as a reference.

To align format 1, make sure that FORMAT 1 or FORMAT 1&2 is selected. To align format 2, make sure that FORMAT 2 or FORMAT 1&2 is selected.

To match the electronic format markings with the fibre screen markings proceed as follows:

- Point the film camera towards a bright object so that the format markings on the fibre screen are clearly visible. These are best seen if the camera lens is thrown out of focus.
- Move the cursor \rightarrow with the keys \uparrow and \downarrow to the line – POSITION 1 \blacksquare or – POSITION 2 \blacksquare , depending on whether format 1 or format 2 is to be adjusted. The symbol \blacksquare indicates that the top line and the left line can be moved. Enter the positioning mode by pressing the keys \rightarrow or \leftarrow . The display will show $\leftarrow \rightarrow \wedge \vee E$. To move the top line up and down, use the keys \uparrow and \downarrow . When the desired position has been set, press the key ENTER/INSERT to leave the positioning mode. To move the vertical line left and right, use the keys \rightarrow or \leftarrow .
- Move the cursor \rightarrow with the keys \uparrow and \downarrow to the line – POSITION 1 \blacksquare or – POSITION 2 \blacksquare , depending on whether format 1 or format 2 should get adjusted. The symbol \blacksquare indicates that the lower line can be moved. Enter the positioning mode by pressing the keys \rightarrow or \leftarrow . The display will show $\leftarrow \rightarrow \wedge \vee E$. To move the top line up and down, use the keys \uparrow and \downarrow . When the desired position has been set, press the key ENTER/INSERT to leave the positioning mode. To move the vertical line left and right, use the keys \rightarrow or \leftarrow .

White Level – Setting the Brightness of the Format Markings

The brightness of the format markings can be set to black (0), dark grey (1), and light grey (2) or white (3).

- Move the cursor ➤ with the keys ▲ and ▼ to the line – WHITE LEVEL. Pressing the key ▶ will switch the settings from 0 to 1 to 2 to 3 and back to 0, pressing the key ◀ will step through the settings in the opposite direction.

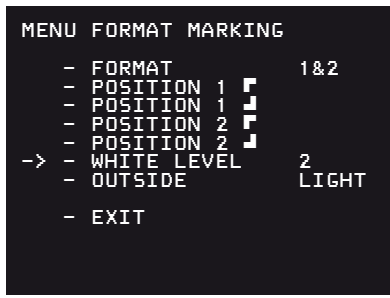

Outside – Darkening the Area outside of the Format Markings



This function is only available if one or both format markings is activated.

The brightness of the area outside of one format marking can be reduced electronically to emphasize the important image area.

- Move the cursor ➤ with the keys ▲ and ▼ to the line – OUTSIDE. Pressing the key ▶ will switch from no shading (VID), light shading (LIGHT), dark shading (DARK) to black (BLACK) and back to VID. Pressing the key ◀ will step through the options in the opposite direction.

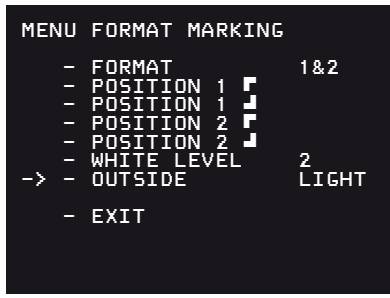

```
MENU FORMAT MARKING
- FORMAT                1&2
- POSITION 1             F
- POSITION 1             F
- POSITION 2             F
- POSITION 2             F
- WHITE LEVEL          2
- OUTSIDE              LIGHT
-> - EXIT
```

Exit

Use exit to return to the main menu.

- Move the cursor \rightarrow with the keys \uparrow and \downarrow to the line
– EXIT and press the key \rightarrow or \leftarrow .

Note: Pressing the Enter/Insert key  for more than three seconds will cause the system to exit the on-screen programming mode completely, regardless of which menu is activated, with the exception of the positioning mode.

10.4.7 Compare/Store Menu

The IVS can grab and store a selected image, display it or overlay it against the live image in front of the camera to compare both images.



*Changes made to settings are immediately activated.
Check all settings on a correctly adjusted monitor.*

- Enter the Compare/Store submenu from the main menu.

Display mode

Display mode allows the option of selecting whether a live image, a stored image or both images in an alternating display mode are displayed. (Please see next chapter Store Image how to store an image.)

- Move the cursor \rightarrow with the keys \uparrow and \downarrow to the line – VIEW MODE. Pressing the key \rightarrow will switch from LIVE to STORD to COMP and back to LIVE. The key \leftarrow will step through in the opposite direction.

If LIVE is selected, the live IVS image will be displayed. If STORD is selected, the currently stored image will be displayed (a black screen means there is no stored image) and if COMP is selected, the live image and the stored image will alternate to show the difference of both images.

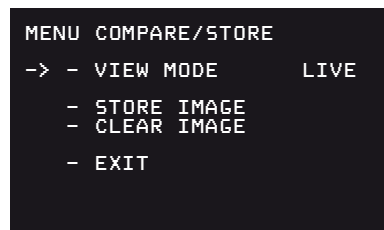
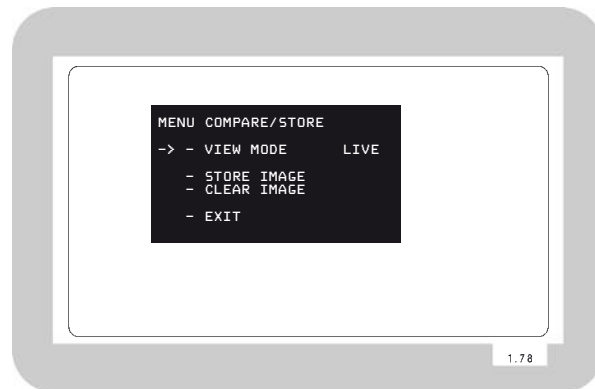







The stored image is memorized until it is overwritten by a new stored image, cleared with the CLEAR IMAGE option or until the IVS or 416 power is turned off.

```
MENU COMPARE/STORE
- VIEW MODE      LIVE
-> - STORE IMAGE
  - CLEAR IMAGE
- EXIT
```





```
MENU COMPARE/STORE
- VIEW MODE      LIVE
- STORE IMAGE
-> - CLEAR IMAGE
- EXIT
```

Store image

The IVS can grab and store a selected image, display it or overlay it against the live image in front of the camera to compare both images. Although the options to display the stored image and to compare the stored image against the live image are only available in the on-screen program mode, it is possible to store an image any time using the Enter/Insert key . To do so, make sure not to be in a control menu and press the Enter/Insert key  shortly, approx. 1.5 seconds. In parallel it is possible to use the on-screen menu:

- Move the cursor  with the keys  and  to the line – STORE IMAGE. Pressing the  or  keys will store the image. The word **DONE** will appear for a few seconds to show that an image was stored.
- The stored image is memorized until a new image is stored, the image is cleared or until the IVS or 416 power was is turned off.

Clear image

- To clear an image, move the cursor  with the keys  and  to the line – CLEAR IMAGE. Pressing the  or  keys will delete the image. The word **DONE** will appear for a few seconds to show that an image was deleted.

Exit

Use exit to return to the main menu.

- Move the cursor \rightarrow with the keys \uparrow and \downarrow to the line
– EXIT and press the key \rightarrow or \leftarrow .

Note: Pressing the Enter/Insert key $\text{\textcircled{ENTER/INSERT}}$ for more than three seconds will cause the system to exit the on-screen programming mode completely, regardless of which menu is activated, with the exception of the positioning mode.

```
MENU COMPARE/STORE
- VIEW MODE      LIVE
- STORE IMAGE
- CLEAR IMAGE
-> - EXIT
```

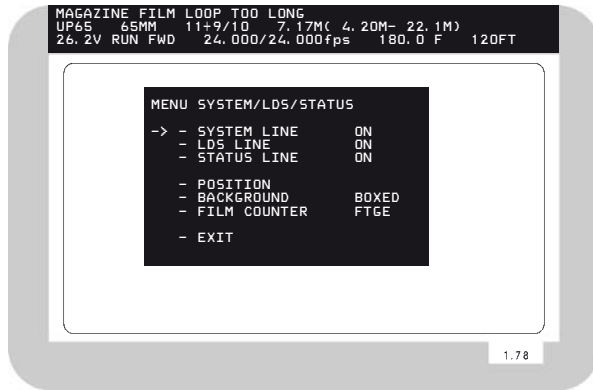

10.4.8 System, LDS and Status Menu

The IVS can insert the camera system, lens data and status into the video image.

The System line inserts information from the film camera such as:

- Async
- Inching
- Low Battery
- Magazine Film Loop Too Long
- Magazine Film Loop Too Short

When the System line is switched on, an additional line of information will appear when required, similar to this:

MAGAZINE FILM LOOP TOO LONG

The Lens Data line contains information about the Lens and Lens settings such as:

- Lens Type
- Actual focal length
- Actual Iris
- Actual focus
- Depth of field (near point, far point)

When the LDS line is switched on, an additional line of information will appear, similar to this:

UP65 65MM 11+9/10 7.17M(4.20M- 22.10M)

Additionally, the Status Line makes it possible to insert camera status information in a separate line, such as:

- Actual voltage of the power supply
- Camera Status (RUN, STANDBY, NOT READY)
- Actual camera speed
- Preset camera speed
- Actual shutter opening
- Film counter information

The film counter gets its data from the film camera. So the data on the IVS is identical to the data in the film camera.

If the film counter is in the take mode, the data in meters, feet or seconds of the last take is displayed. In the footage mode, the total length of the film run through the camera is displayed, either in meters or feet.



During on-screen programming inserted data is not fully updated (e. g. Frame Counter Information). To update the information, leave the on-screen display menu by pressing the Enter/Insert key  for more than three seconds.



When the film camera is first switched on, no mirror shutter angle is displayed. Data only appears after a few revolutions of the mirror shutter.

The System line, LDS line and Status line live together as a package. If all lines are on, the upper line will always be system, the middle line LDS and the lower line status. Positioning always affects all lines together.

Like all man readable information, the data is inserted as a window on the monitor image. Each window can be switched on and off independently. Background and position can be altered without affecting the settings of other windows.

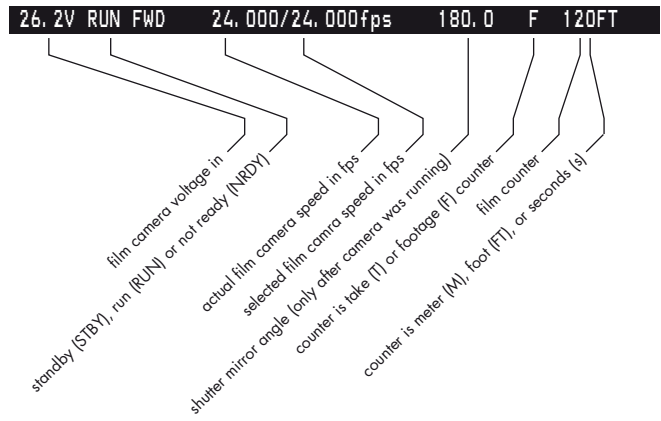

The adjustment of the white level of the inserted data, an inverse display and a fine adjustment of the vertical position is described in chapters 10.4.5 White Level, Inverse and Fine Positioning.

- Enter the System/LDS/Status submenu from the main menu.



Changes made to settings are immediately activated. Check all settings on a correctly adjusted monitor.

```
MENU SYSTEM/LDS/STATUS
```

```
-> - SYSTEM LINE      ON
    - LENS DATA LINE ON
    - STATUS LINE     ON

    - POSITION
    - BACKGROUND      BOXED
    - FILM COUNTER    FTGE

    - EXIT
```

System Line

This sub menu line switches the insertion of camera system data on (ON) and off (OFF) independently of other inserted data.

- Move the cursor \rightarrow with the keys \uparrow and \downarrow to the line – SYSTEM LINE. The keys \rightarrow or \leftarrow switch the insertion on and off.

A line similar to the depicted line will appear:

LOW BATTERY



The menu options Position and Background are only available if one of the three information lines is on. The menu option Film Counter is only available when the Status Line is on.

To clear this message, eliminate the cause of the problem. In this example, change the battery for a fully charged one.

LDS Line

This sub menu line switches the insertion of Lens Data (LDS) information on (ON) and off (OFF) independently of other inserted data.

- Move the cursor \rightarrow with the keys \uparrow and \downarrow to the line - LDS LINE. The keys \rightarrow or \leftarrow switch the insertion on and off.

```
MENU SYSTEM/LDS/STATUS
- SYSTEM LINE      ON
-> - LENS DATA LINE  ON
- STATUS LINE      ON

- POSITION
- BACKGROUND      BOXED
- FILM COUNTER     FTGE

- EXIT
```

A line similar to the depicted line will appear:

```
UP65  65MM  11+9/10  7.17M  ( 4.20M- 22.10M)
```



The menu options Position and Background are only available if one of the three information lines is on. The menu option Film Counter is only available when the Status Line is on.

```
MENU SYSTEM/LDS/STATUS
- SYSTEM LINE      ON
- LENS DATA LINE  ON
-> - STATUS LINE    ON

- POSITION           BOXED
- BACKGROUND        FTGE
- FILM COUNTER      FTGE
- EXIT
```

Status Line

This sub menu line switches the insertion of camera status data on (ON) and off (OFF) independently of other inserted data.

- Move the cursor \rightarrow with the keys \uparrow and \downarrow to the line - STATUS LINE. The keys \rightarrow or \leftarrow switch the insertion on and off.

A line similar to the depicted line will appear:

```
26.2V RUN FWD 24.000/24.000fps 180.0 F 120FT
```



The menu options Position and Background are only available if one of the three information lines is on. The menu option Film Counter is only available when the Status Line is on.

Position

The window can be positioned anywhere on the monitor screen.



The menu option Position is only available if at least one of the three information lines is on.

- Move the cursor \rightarrow with the keys \uparrow and \downarrow to the line - POSITION. Enter the positioning mode with the \rightarrow or \leftarrow keys. The following menu is displayed on the screen:

```
-> - POSITION ^v E
```

- The \uparrow and \downarrow keys move the window up and down. When the desired position has been set, confirm by pressing the Enter/Insert key .

```
MENU SYSTEM/LDS/STATUS
- SYSTEM LINE ON
- LENS DATA LINE ON
- STATUS LINE ON
-> - POSITION
- BACKGROUND BOXED
- FILM COUNTER FTGE
- EXIT
```

MENU SYSTEM/LDS/STATUS

```
- SYSTEM LINE      ON
- LENS DATA LINE  ON
- STATUS LINE      ON

- POSITION
-> - BACKGROUND     BOXED
- FILM COUNTER     FTGE

- EXIT
```

MENU SYSTEM/LDS/STATUS

```
- SYSTEM LINE      ON
- LENS DATA LINE  ON
- STATUS LINE      ON

- POSITION
-> - BACKGROUND     BOXED
- FILM COUNTER     TAKE
                   (SEC)

- EXIT
```

Background

The background of the window can be set electronically to black in normal display mode or to white in inverse mode (BOXED) to improve the readability. If this is not activated, the area around the text is the normal video image (VIDEO).



The menu option Background is only available if at least one of the three information lines is on.

- Move the cursor \rightarrow with the \uparrow and \downarrow keys to the line - BACKGROUND. The \rightarrow or \leftarrow key switches between BOXED and VIDEO.

Film Counter

The film counter is slaved to the footage counter of the film camera. It always displays the values, which are in the camera. Therefore there is no set or reset of film counter data on the IVS.



The menu options Position and Background are only available if one of the three information lines is on. The menu option Film Counter is only available if the Status line is on.

- Move the cursor \blacktriangleright with the \blacktriangle and \blacktriangledown keys to the line – FILM COUNTER. The \blacktriangleright key will switch from TAKE (M/FT), TAKE (SEC) to FTGE and back to TAKE (M/FT). The \blacktriangle key will step through the options in the reverse order.

Note: The unit of measurement meters or feet is taken from the setting of the camera. If the unit of measurement on the 416 is set to meters, the data on the IVS is also displayed in meters.

Exit

Use exit to return to the main menu.

- Move the cursor \blacktriangleright with the keys \blacktriangle and \blacktriangledown to the line – EXIT and press the key \blacktriangleright or \blacktriangleleft .

Note: Pressing the Enter/Insert key (ENTER/INSERT) for more than three seconds will cause the system to exit the on-screen programming mode completely, regardless of which menu is activated, with the exception of the positioning mode.

```
MENU SYSTEM/LDS/STATUS
- SYSTEM LINE      ON
- LENS DATA LINE  ON
- STATUS LINE      ON

- POSITION
- BACKGROUND       BOXED
- FILM COUNTER     FTGE
-> - EXIT
```

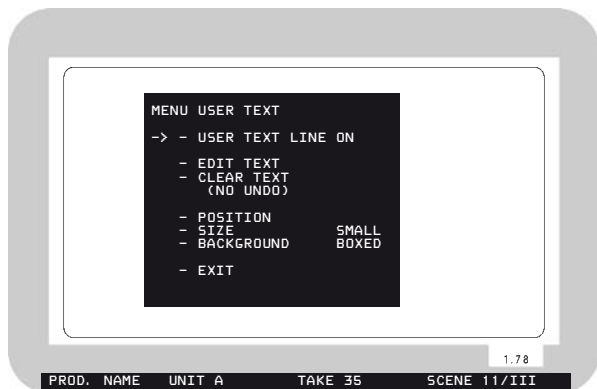

10.4.9 User Text Menu

The IVS can insert additional text into the video image, e.g. the production name or a scene number. The text can be entered on the IVS using the text edit facility or the ARRI software User Text Line IVS (downloadable from the ARRI website).

If information is stored in the text memory, it will remain there until the memory is cleared or new text overwrites the old. The text memory is retained even if the IVS or the camera is switched off and disconnected from the power supply. This enables, for example, a camera rental house to store information, which is then available to the production team. e.g. the production name.

Like all man readable information, the data is inserted as a window on the monitor image. The window can be switched on and off independently. Background, position and character format can be altered without affecting the settings of other windows.

This additional line shows the text information, similar to this:

```
PROD. NAME UNIT A TAKE 35 SCENE 11/III
```

The adjustment of the white level of the inserted data, an inverse display and a fine adjustment of the vertical position is described in chapters 10.4.5 White Level, Inverse and Fine Positioning.

- Enter the User Text submenu from the main menu.



*Changes made to settings are immediately activated.
Check all settings on a correctly adjusted monitor.*

User Text Line

This sub menu line switches the insertion of User Text on (ON) and off (OFF) independently of other inserted data.

- Move the cursor \rightarrow with the \uparrow and \downarrow keys to the line – USER TEXT LINE. The \rightarrow or \leftarrow keys switch the insertion on and off.

The default text is all characters dotted.

Edit Text using the internal text editing facility

The text can be edited on the IVS without the need for additional devices.

- Move the cursor \rightarrow with the \uparrow and \downarrow keys to the line – EDIT TEXT. Activate the edit menu with the \rightarrow or \leftarrow keys.
- This will lead into the editing submenu.

```
MENU USER TEXT
-> - USER TEXT LINE ON
    - EDIT TEXT
    - CLEAR TEXT
      (NO UNDO)

    - POSITION
    - SIZE                SMALL
    - BACKGROUND         BOXED

    - EXIT
```

```
MENU USER TEXT
    - USER TEXT LINE ON
-> - EDIT TEXT
    - CLEAR TEXT
      (NO UNDO)

    - POSITION
    - SIZE                SMALL
    - BACKGROUND         BOXED

    - EXIT
```

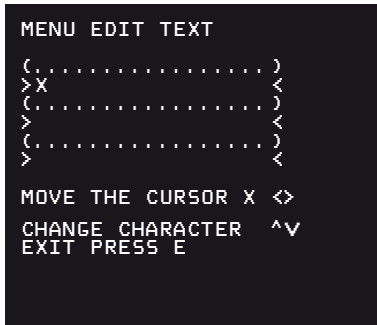

The menu EDIT TEXT is displayed on the screen:

- The X Symbol shows the position in the user text line that is to be changed. Move this text inserter cursor X left and right with the \blacktriangleleft and \blacktriangleright keys to the desired position.
- Change the character to be inserted with the \blacktriangleup and \blacktriangledown keys.
- Once the desired character is selected, move the text inserter cursor X to the next position.
- To leave the text edit mode, press the Enter/Insert key . This will lead back to the user text menu.

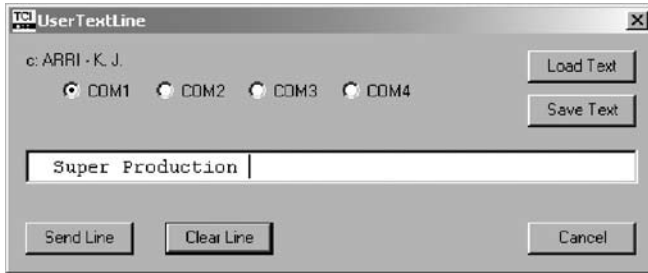

Edit Text using the ARRI software User Text Line IVS

- Connect a computer to the ARRIFLEX 416 camera using a cable KC 89-S (K2.65002.0). Connect the cable between the REMOTE connector on the camera side and the serial port on the computer. Computers with no serial interface, such as new laptops, can use a USB to serial adapter, which is available in computer hardware shops.
- Select the output channel on your computer (COM 1 to COM 4).
- Make sure that the USER TEXT LINE is switched on
- Type the necessary information into the editing line. Click the Send Line button to send the text the IVS.
- Save Text allows you to store a text line, Load Text loads a text line from the hard disc into the editing line.

Clear Text using the internal text editing facility

The user text line can be cleared on the IVS without an external device. When the text is cleared, the default line, a dotted line will appear.



Text cleared from the IVS is lost and cannot be recalled.

- Move the cursor \rightarrow with the \uparrow and \downarrow keys to the line - CLEAR TEXT. Press the \rightarrow or \leftarrow keys to clear the line.

Position

The window can be positioned anywhere on the monitor screen.

- Move the cursor \rightarrow with the \uparrow and \downarrow keys to the line - POSITION. Activate the positioning mode with the \rightarrow or \leftarrow keys. The following menu is displayed on the screen:

```
-> - POSITION ^v E
```

- The \uparrow and \downarrow keys move the window up and down. When the desired position has been set, confirm by pressing the Enter/Insert key .

```
MENU USER TEXT
  - USER TEXT LINE ON
  - EDIT TEXT
-> - CLEAR TEXT
    (NO UNDO)

  - POSITION
  - SIZE SMALL
  - BACKGROUND BOXED

  - EXIT
```

```
MENU USER TEXT
  - USER TEXT LINE ON
  - EDIT TEXT
  - CLEAR TEXT
    (NO UNDO)
-> - POSITION
  - SIZE SMALL
  - BACKGROUND BOXED

  - EXIT
```

```
MENU USER TEXT
- USER TEXT LINE ON
- EDIT TEXT
- CLEAR TEXT
  (NO UNDO)
- POSITION
-> - SIZE          SMALL
  - BACKGROUND    BOXED
- EXIT
```

```
MENU USER TEXT
- USER TEXT LINE ON
- EDIT TEXT
- CLEAR TEXT
  (NO UNDO)
- POSITION
-> - SIZE          SMALL
  - BACKGROUND    BOXED
- EXIT
```

Size

The size of the window can be changed independently from other inserts.

- Move the cursor \rightarrow with the \uparrow and \downarrow keys to the line – SIZE. The key \rightarrow will switch from SMALL, WIDE, HIGH to BIG and back to SMALL. The \leftarrow key will switch in opposite direction.

Background

The background of the window can be set electronically to black in normal display mode or to white in inverse mode (BOXED) to improve the readability. If this is not activated, the area around the text is the normal video image (VIDEO).

- Move the cursor \rightarrow with the \uparrow and \downarrow keys to the line – BACKGROUND. The \rightarrow or \leftarrow keys switch between BOXED and VIDEO.

Exit

Use exit to return to the main menu.

- Move the cursor \rightarrow with the \uparrow and \downarrow keys to the line
– EXIT and press the \rightarrow or \leftarrow keys.

Note: Pressing the Enter/Insert key  for more than three seconds will cause the system to exit the on-screen programming mode completely, regardless of which menu is activated, with the exception of the positioning mode.

```
MENU USER TEXT
- USER TEXT LINE ON
- EDIT TEXT
- CLEAR TEXT
  (NO UNDO)
- POSITION
- SIZE          SMALL
- BACKGROUND    BOXED
-> - EXIT
```

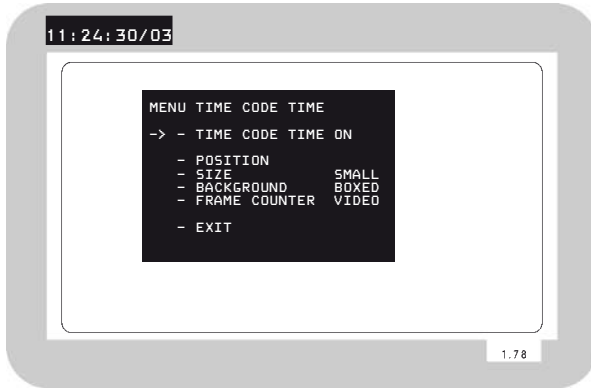

10.4.10 Timecode Menu

The IVS can burn the film camera's timecode into the video assist image to create a direct link to the post production.

It is possible to insert either timecode, which is related to the film camera speed, e.g. 24 fps or a timecode which counts according to the type of video assist (25 full video frames per second with PAL or 30 full video frames per second with NTSC).

Like all man readable information, the data is inserted as a window on the monitor image. The window can be switched on and off independently. Background, position and character format can be altered without affecting the settings of other windows.

The adjustment of the white level of the inserted data, an inverse display and a fine adjustment of the vertical position is described in chapter 10.4.5

This additional line shows the TC information:

11:24:30/03

- Note: The frame information (the last two digits of the timecode display) is only active if timecode is actually recorded on film. If there is no timecode recording on film, because for example the camera is not running at a timecode speed, only the symbol ** is displayed in that position.
- Enter the Timecode Menu from the Main Menu.



*Changes made to settings are immediately activated.
Check all settings on a correctly adjusted monitor.*

TC Time

This sub menu line switches the insertion of timecode data on (ON) and off (OFF) independently of other inserted data.

- Move the cursor \blacktriangleright with the \blacktriangle and \blacktriangledown keys to the line – TIMECODE TIME. The \blacktriangleright or \blacktriangleleft keys switch the insertion on and off.

```
MENU TIME CODE TIME
-> - TIME CODE TIME ON
- POSITION
- SIZE SMALL
- BACKGROUND BOXED
- FRAME COUNTER VIDEO
- EXIT
```

```

MENU TIME CODE TIME
- TIME CODE TIME ON
-> - POSITION
- SIZE          SMALL
- BACKGROUND    BOXED
- FRAME COUNTER VIDEO
- EXIT
    
```

```

MENU TIME CODE TIME
- TIME CODE TIME ON
-> - POSITION
- SIZE          SMALL
- BACKGROUND    BOXED
- FRAME COUNTER VIDEO
- EXIT
    
```

Position

The window can be positioned anywhere on the monitor screen.

- Move the cursor \rightarrow with the \uparrow and \downarrow keys to the line – POSITION. Activate the positioning mode with the \rightarrow or \leftarrow keys. The following menu is displayed on the screen:

```

-> - POSITION          <> ^ v E
    
```

- The \uparrow and \downarrow keys move the window up and down. The \leftarrow and \rightarrow keys move it left and right. When the desired position has been set, confirm by pressing the Enter/Insert key .

Size

The size of the window can be changed independently from other inserts.

- Move the cursor \rightarrow with the \uparrow and \downarrow keys to the line – SIZE. The \rightarrow key will switch from SMALL, WIDE, HIGH to BIG and back to SMALL. The \leftarrow key will switch in opposite direction.

Background

The background of the window can be set electronically to black in normal display mode or to white in inverse mode (BOXED) to improve the readability. If this is not activated, the area around the text is the normal video image (VIDEO).

- Move the cursor \rightarrow with the \uparrow and \downarrow keys to the line - BACKGROUND. The \rightarrow or \leftarrow keys switch between BOXED and VIDEO.

Frame Counter



It is recommended the camera user checks the requirements of all parties involved in post-production prior to shooting.

Frequently the camera is set to run at a different speed from that of the video system. In areas with NTSC video system for example, the film camera might run at 24 fps whereas the video system works with 30 full video frames per second. In order to adapt to these specific needs there are two different timecode formats possible.

```
MENU TIME CODE TIME
- TIME CODE TIME ON
- POSITION
- SIZE SMALL
-> - BACKGROUND BOXED
- FRAME COUNTER VIDEO
- EXIT
```

```
MENU TIME CODE TIME
- TIME CODE TIME ON
- POSITION
- SIZE SMALL
-> - BACKGROUND BOXED
- FRAME COUNTER VIDEO
- EXIT
```

To have the timecode count related to the film camera, select the mode "Frame counter Film" which is often referred to as "film related timecode". In this mode, the frame counter of the timecode (the last two digits of the timecode display) is increased by 1 if the film is advanced by one frame e.g. 24 times a second at 24 fps. This way it is easy to identify one particular film frame by looking at the video image. On the other hand, this mode will create an unusual timecode count because some video images are repeated to cope with the different frame rates of the video and the film camera. These repeated images will get duplicated timecode words which will create error messages on some timecode readers.

To relate the timecode count to the video system, select "Frame counter Video". This is often referred to as "video related timecode". Every full video frame will advance the timecode by 1 e.g. 25 times a second in PAL or 30 times a second in NTSC. In this mode the IVS creates a standard timecode. On the other hand, it is more difficult to restore the link back to the timecode, which was recorded on film. To get a reliable relation, it is necessary to utilize the Pull-Down (refer to chapter 6.8) or White Line Flag information (refer to chapter 6.11).

At every full second, both time counts are identical.

In case of "Frame counter Film" there will be a / before the frame count (the last two digits of the timecode display), in case of "Frame counter Video" there will be a : ⇒ **photo**.

11:24:30/03

11:24:30:03

11:24:30/**



*The Frame count is only active if timecode is actually recorded on Film. In all other cases a ** ⇒ **photo** symbol will appear in place of the frame count.*



Timecode is only recorded on film at standard speeds. These are 23.976 fps, 24 fps, 25 fps, 29.97 fps and 30 fps. At all other speeds, timecode is displayed on the video assist without the frame count and it is not recorded on film.



Timecode is only valid when Flicker Free is on.

- Move the cursor ➤ with the ▲ and ▼ keys to the line – FRAME COUNTER. The ▶ or ◀ keys switch the frame counter mode between "FILM" and "VIDEO".

Exit

Return to the main menu using Exit.

- Move the cursor \rightarrow with the keys \uparrow and \downarrow to the line
– EXIT and press the key \rightarrow or \leftarrow .

Note: Pressing the Enter/Insert key  for more than three seconds will cause the system to exit the on-screen programming mode completely, regardless of which menu is activated, with the exception of the positioning mode.

```
MENU TIME CODE TIME
- TIME CODE TIME ON
- POSITION
- SIZE SMALL
- BACKGROUND BOXED
- FRAME COUNTER VIDEO
-> - EXIT
```

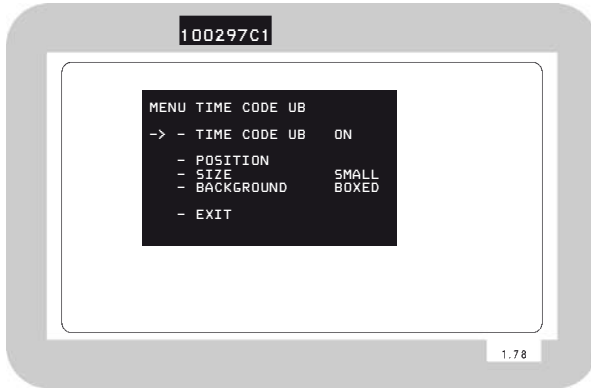

10.4.11 USER BITS Menu

The IVS can insert the User Bits of the film camera's timecode into the video assist image to create a direct link to the post production.

Like all man readable information, the data is inserted as a window on the monitor image. The window can be switched on and off independently. Background, position and character format can be altered without affecting the settings of other windows.

The adjustment of the white level of the inserted data, an inverse display and a fine adjustment of the vertical position is described in chapter 10.4.5

This additional line shows the User Bit information:

100279C1

- Enter the User Bits Menu from the Main Menu.



*Changes made to settings are immediately activated.
Check all settings on a correctly adjusted monitor.*

TC Ubit

This sub menu line switches the insertion of User Bit data on (ON) and off (OFF) independently of other inserted data.

- Move the cursor \rightarrow with the \uparrow and \downarrow keys to the line – TC UBIT. The \rightarrow or \leftarrow keys switch the insertion on and off.

```
MENU TIME CODE UB
-> - TIME CODE UB   ON
    - POSITION
    - SIZE           SMALL
    - BACKGROUND    BOXED
    - EXIT
```

Position

The window can be positioned anywhere on the monitor screen.

- Move the cursor \rightarrow with the \uparrow and \downarrow keys to the line – POSITION. Activate the positioning mode with the \rightarrow or \leftarrow keys. The following menu is displayed on the screen:

```
-> - POSITION          <math>\leftrightarrow</math> ^v E
```

- The \uparrow and \downarrow keys move the window up and down. The \leftarrow and \rightarrow keys move it left and right. When the desired position has been set, confirm by pressing the Enter/Insert key $\text{\textcircled{ENTER/INSERT}}$.

```
MENU TIME CODE UB
    - TIME CODE UB   ON
-> - POSITION
    - SIZE           SMALL
    - BACKGROUND    BOXED
    - EXIT
```

```
MENU TIME CODE UB
- TIME CODE UB   ON
- POSITION
-> - SIZE          SMALL
- BACKGROUND     BOXED
- EXIT
```

```
MENU TIME CODE UB
- TIME CODE UB   ON
- POSITION
-> - SIZE          SMALL
- BACKGROUND     BOXED
- EXIT
```

Size

The size of the window can be changed independently from other inserts.

- Move the cursor \rightarrow with the keys \uparrow and \downarrow keys to the line – SIZE. The \rightarrow key will switch from SMALL, WIDE, HIGH to BIG and back to SMALL. The \leftarrow key will switch in opposite direction.

Background

The background of the window can be set electronically to black in normal display mode or to white in inverse mode (BOXED) to improve the readability. If this is not activated, the area around the text is the normal video image (VIDEO).

- Move the cursor \rightarrow with the \uparrow and \downarrow keys to the line – BACKGROUND. The \rightarrow or \leftarrow keys switch between BOXED and VIDEO.

Exit

Return to the main menu using Exit.

- Move the cursor \rightarrow with the \uparrow and \downarrow keys to the line
– EXIT and press the \rightarrow or \leftarrow keys.

Note: Pressing the Enter/Insert key  for more than three seconds will cause the system to exit the on-screen programming mode completely, regardless of which menu is activated, with the exception of the positioning mode.

```
MENU TIME CODE UB
- TIME CODE UB ON
- POSITION
- SIZE SMALL
- BACKGROUND BOXED
-> - EXIT
```

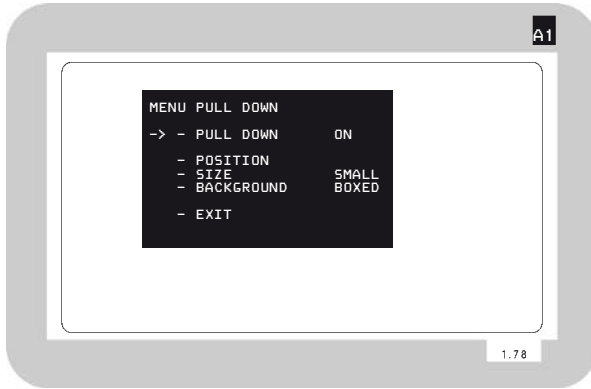

10.4.12 Pull-Down Menu

The IVS can generate information on whether the current video image corresponds to a new film frame or whether it is a repeated video image. The Pull-Down information displays that in man readable form.

The adjustment of the white level of the inserted data, an inverse display and a fine adjustment of the vertical position is described in chapter 10.4.5

This additional window shows the pull-down information:



- Enter the Pull-Down Menu from the Main Menu.



*Changes made to settings are immediately activated.
Check all settings on a correctly adjusted monitor.*

All video assists are based either on PAL or NTSC video systems, with a fixed video frequency of either 25 full video frames per second with PAL or 29.97 full video frames per second with NTSC. The speed of the film camera on the other hand can be selected over a wide range. At every film speed which is different from the video frequency, the IVS has to add repeated video fields to compensate for the different frame rates.

In practice the most important case is a film camera speed of 23.976 fps and a NTSC video assist.

This creates the situation described in the drawing.

From the first film frame, two video fields are derived, the second film frame, three video fields are derived, from the next film frame, two video fields and so on.

The Pull-Down information is created as follows:

Every time, the video field corresponds to a new film frame, the letter will change either from A to B or B to A and the number will be set to 1. As long as no new film frame is taken, the video fields are counted, beginning from 1. Consequently A2 is the first repetition of A1. B2 would be the first repetition of B1, B3 would be the second repetition.

In spite of the fact that the name Pull-Down comes from the working practice in the NTSC systems, where on a telecine the film is running on 23.976 fps and gets converted to 29.97 fps, the definition of Pull-Down information on the IVS can also be applied to PAL and to film speeds other than 23.976 fps.

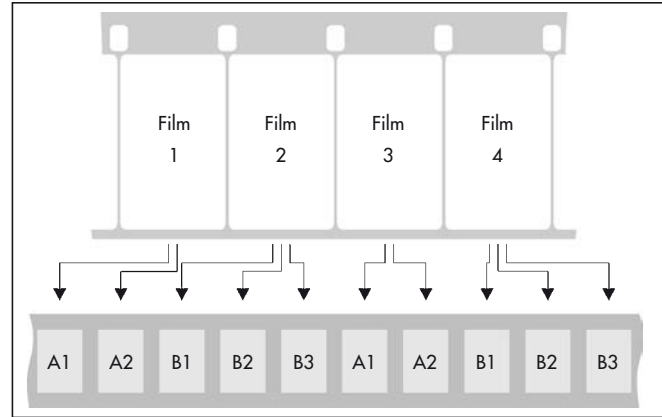

Like all man readable information, the data is inserted as a window on the monitor image. The window can be switched on and off independently. Background, position and character format can be altered without affecting the settings of other windows.

Note: Pull-Down information is only inserted when timecode is actually recorded on film. If there is no timecode recording, for example because the camera is not running on a timecode speed, only A1 will be displayed.

```
MENU PULL DOWN
-> - PULL DOWN      ON
    - POSITION
    - SIZE          SMALL
    - BACKGROUND    BOXED
    - EXIT
```

```
MENU PULL DOWN
    - PULL DOWN      ON
-> - POSITION
    - SIZE          SMALL
    - BACKGROUND    BOXED
    - EXIT
```

Pull-Down

This sub menu line switches the insertion of pull down information on (ON) and off (OFF) independently of other inserted data.

- Move the cursor \rightarrow with the \uparrow and \downarrow keys to the line – PULL DOWN. The \rightarrow or \leftarrow keys switch the insertion on and off.

Position

The window can be positioned anywhere on the monitor screen.

- Move the cursor \rightarrow with the \uparrow and \downarrow keys to the line – POSITION. Activate the positioning mode with the \rightarrow or \leftarrow keys. The following menu is displayed on the screen:

```
-> - POSITION  $\leftrightarrow$  ^v E
```

- The \uparrow and \downarrow keys move the window up and down. The \leftarrow and \rightarrow keys move it left and right. When the desired position has been set, confirm by pressing the Enter/Insert key $\text{\textcircled{ENTER/INSERT}}$.

Size

The size of the window can be changed independently from other inserts.

- Move the cursor \rightarrow with the \uparrow and \downarrow keys to the line – SIZE. The \rightarrow key will switch from SMALL, WIDE, HIGH to BIG and back to SMALL. The \leftarrow key will switch in the opposite direction.

```
MENU PULL DOWN
- PULL DOWN      ON
- POSITION
-> - SIZE          SMALL
- BACKGROUND      BOXED
- EXIT
```

Background

The background of the window can be set electronically to black in normal display mode or to white in inverse mode (BOXED) to improve the readability. If this is not activated, the area around the text is the normal video image (VIDEO).

- Move the cursor \rightarrow with the \uparrow and \downarrow keys to the line – BACKGROUND. The \rightarrow or \leftarrow keys switch between BOXED and VIDEO.

```
MENU PULL DOWN
- PULL DOWN      ON
- POSITION
-> - BACKGROUND    SMALL
-                BOXED
- EXIT
```

```
MENU PULL DOWN
- PULL DOWN      ON
- POSITION
- SIZE            SMALL
- BACKGROUND     BOXED
-> - EXIT
```

Exit

Return to the main menu using Exit.

- Move the cursor \rightarrow with the \uparrow and \downarrow keys to the line
– EXIT and press the \rightarrow or \leftarrow keys.

Note: Pressing the Enter/Insert key  for more than three seconds will cause the system to exit the on-screen programming mode completely, regardless of which menu is activated, with the exception of the positioning mode.

10.4.13 VITC Line Menu

The IVS can convert the timecode, which can also be displayed man-readable in the video image, into machine readable VITC (Vertical Interval Time-Code) and place it in non visible video lines.

Note: The timecode count that is used (“film related” or “video related timecode”) depends on the settings of the line “Frame Counter” in the sub menu “Timecode” (see chapter 10.4.10).

Note: VITC is only output if timecode is actually recorded on film. If no timecode is recorded on film for example because the camera is not running at a timecode speed, no VITC is available.

Note: The White Line has priority over VITC lines. If the same line is selected for White Line as well as for VITC, White Line will appear.

- Enter the VITC Line Menu from the Main Menu.



*Changes made to settings are immediately activated.
Check all settings on a correctly adjusted monitor.*

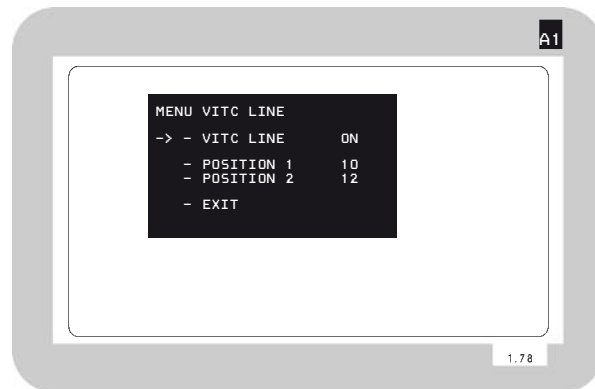

```
MENU VITC LINE
-> - VITC LINE      ON
   - POSITION 1      10
   - POSITION 2      12
   - EXIT
```

```
MENU VITC LINE
   - VITC LINE      ON
-> - POSITION 1      10
   - POSITION 2      12
   - EXIT
```

VITC

This sub menu line switches the insertion of VITC on (ON) and off (OFF).

- Move the cursor \rightarrow with the \uparrow and \downarrow keys to the line - VITC. The \rightarrow and \leftarrow keys switch the insertion on and off.

Position 1

The insertion of VITC can be on single or multiple lines between lines 6 and 22. If the same line number is selected on both position 1 and position 2, the insertion will be single line; otherwise it will be multiple lines. The value of position 1 can be higher or lower than that of position 2.

- Move the cursor \rightarrow with the \uparrow and \downarrow keys to the line - POSITION 1. By pressing the \rightarrow key the value will be increased until line 22 is selected. By pressing the \leftarrow key the value will be decreased until line 6 is reached.

Position 2

The insertion of VITC can be on single or multiple lines between lines 6 and 22. If the same line number is selected on both position 1 and position 2, the insertion will be single line; otherwise it will be multiple lines. The value of position 1 can be higher or lower than that of position 2.

- Move the cursor \rightarrow with the \uparrow and \downarrow keys to the line – POSITION 2. By pressing the \rightarrow key the value will be increased until line 22 is selected. By pressing the \leftarrow key the value will be decreased until line 6 is reached.

Exit

Return to the main menu using Exit.

- Move the cursor \rightarrow with the \uparrow and \downarrow keys to the line – EXIT and press the \rightarrow or \leftarrow keys.

Note: Pressing the Enter/Insert key (ENTER/INSERT) for more than three seconds will cause the system to exit the on-screen programming mode completely, regardless of which menu is activated, with the exception of the positioning mode.

```
MENU VITC LINE
- VITC LINE      ON
- POSITION 1      10
-> - POSITION 2    12
- EXIT
```

```
MENU VITC LINE
- VITC LINE      ON
- POSITION 1      10
- POSITION 2      12
-> - EXIT
```

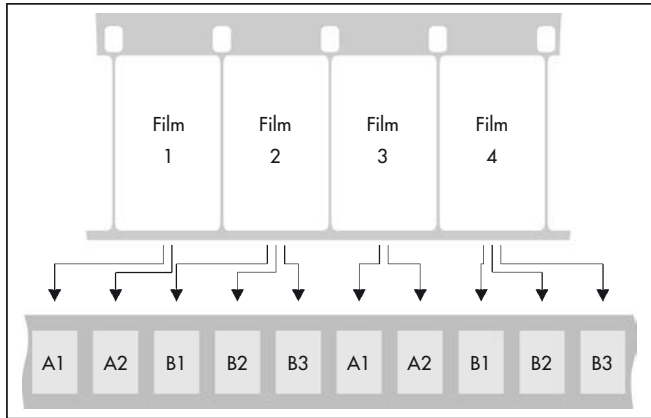
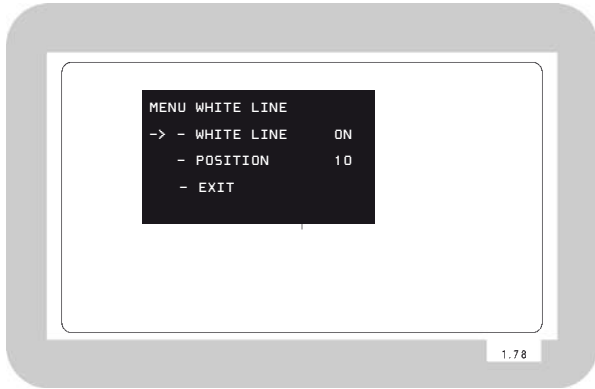

10.4.14 White Line Menu

The IVS can generate information on whether the current video image corresponds to a new film frame or whether it is a repeated video image. The White Line flag displays this in machine readable form.

- Enter the White Line Menu from the Main Menu.



Changes made to settings are immediately activated. Check all settings on a correctly adjusted monitor.

All video assists are based either on PAL or NTSC video systems, with a fixed video frequency of either 25 full video frames per second with PAL or 29.97 full video frames per second with NTSC. The speed of the film camera on the other hand can be selected over a wide range. At every film speed which is different from the video frequency, the IVS has to add repeated video fields to compensate for the different frame rates.

In practice the most important case is a film camera speed of 23.976 fps and a NTSC video assist.

This creates a situation described in the drawing.

From the first film frame, two video fields are derived, the second film frame, three video fields are derived, from the next film frame, two video fields and so on.

The White Line flag works as follows:

Every time, the video field corresponds to a new film frame, the letter will change either from A to B or B to A and the number will be set to 1. As long as no new film frame is taken, the video fields are counted, beginning from 1. Consequently A2 is the first repetition of A1. B2 would be the first repetition of B1, B3 would be the second repetition. On every A1 or B1, the selected video line will get set to video signal white, indicating that only these video frames correlate one-to-one to film frames. The duplicated video fields are not marked.

In spite of the fact that the name Pull-Down comes from the working practice in the NTSC systems, where on a telecine the film is running on 23.976 fps and gets converted to 29.97 fps, the definition of Pull-Down information on the IVS can also be applied to PAL and to film speeds other than 23.976 fps.

Note: The insertion of White Line flags is only done, when timecode is actually recorded on film. If there is no timecode recording, for example because the camera is not running on a timecode speed, no White Line flag is sent out.

Note: The White Line has priority over VITC lines. If the same line is selected for White Line as well as for VITC, White Line will appear.

```
MENU WHITE LINE
-> - WHITE INE      ON
   - POSITION        11
   - EXIT
```

```
MENU WHITE LINE
  - WHITE INE      ON
-> - POSITION        11
  - EXIT
```

White Line

This sub menu line switches the insertion of White Lines on (ON) and off (OFF).

- Move the cursor \rightarrow with the \uparrow and \downarrow keys to the line - WHITE LINE. The \rightarrow and \leftarrow keys switch the insertion on and off.

Position

The insertion of White Lines can be between line 6 and 22.

- Move the cursor \rightarrow with the \uparrow and \downarrow keys to the line - POSITION. By pressing the \rightarrow key the value will be increased until line 22 is selected. By pressing the \leftarrow key the value will be decreased until line 6 is reached.

Exit

Return to the main menu using Exit.

- Move the cursor \rightarrow with the \uparrow and \downarrow keys to the line
– EXIT and press the \rightarrow or \leftarrow keys.

Note: Pressing the Enter/Insert key  for more than three seconds will cause the system to exit the on-screen programming mode completely, regardless of which menu is activated, with the exception of the positioning mode.

```
MENU WHITE LINE
- WHITE INE      ON
- POSITION        11
-> - EXIT
```

11. Timecode

The ARRIFLEX 416 is equipped with a TC generator which produces 80bit Timecode with a data structure conforming to SMPTE RP136, Format Type C. The TC generator is set using a master clock. The precision of the TC generator ensures that for 8 hours after the synchronization (at 0°C - 50°C) the difference remains less than one frame, if the time code generator of the audio machine is precise, too. Every frame is therefore clearly identifiable for synchronization or editing lists.

A new feature on the 416 further improves the accuracy of the synchronization between the 416 TC generator and the master clock. To exploit this feature the camera must be connected to an Ambient Clockit as the master clock.

Timecode is recorded in the magazine, its position on film conforming to SMPTE RP114, at standard speeds of 23.976, 24.00, 25.00, 29.97 and 30.00 fps.

The TC information also includes speed of recording which is described in connection with Timecode as frame rate. For the ARRIFLEX 416 the valid frame rate is always the most recently set standard speed.



For Timecode operation, please make sure that the magazine is equipped with a Timecode exposure module K2.55034.0.

TC-Input

The TC generator integrated in the ARRIFLEX 416 can be synchronized to other equipment with a TC generator. A LTC signal (Longitudinal TimeCode) from any TC generator is plugged into the "TCC" socket. The signal level must be higher than 500 mV p-p. The camera automatically takes on TC time and TC User Bits. If the LTC signal is correctly transferred the TC recording will be automatically switched on.

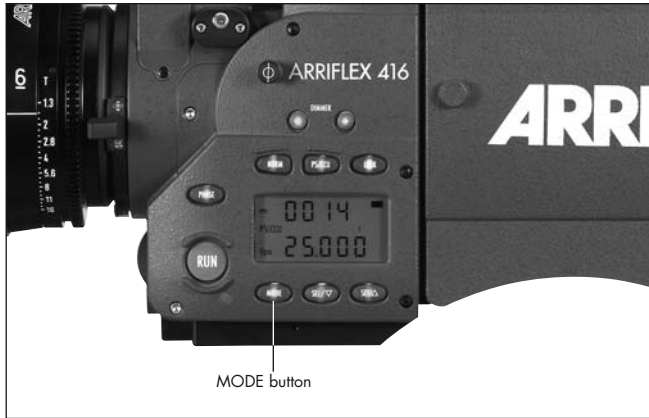

- Using the “MODE” key ⇒ **photo** switch to Mode 4 (Timecode time)
- Plug the cable with the TC signal into the “TCC” socket ⇒ **photo**. The last two entries on the indicator show a blinking “EC” (external code). If the LTC signal is correctly transferred the indication “CC” (correct code) appears for approx. 10 second before the indicator on the generator frame rate switches back.

Note: The CCU is no longer supported and cannot be used for setting Timecode.

Increased accuracy of the TC Generator

The ARRIFLEX 416 TC generator has a new feature to extend the time period required between synchronizations. The camera must be connected to an Ambient Clockit as the master clock. The Ambient Clockit measures the frequency of the 416 TC output, calculates the difference to its own internal clock and puts out an adjustment value to the 416 TC generator.

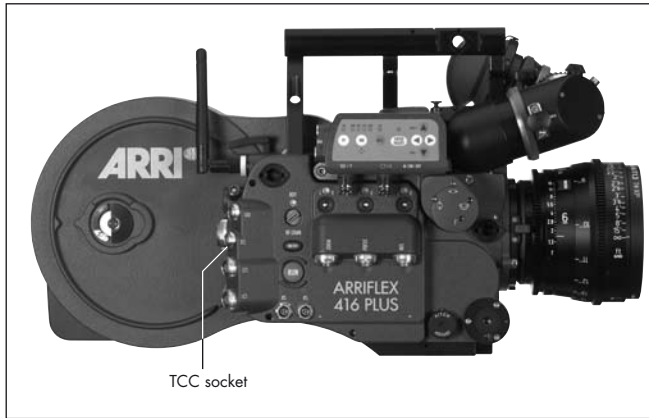

TC Output

TC information is constantly available as 80bit LTC on the "TCC" socket. Output signal is in the LTC format.

From the TC output TC compatible equipment can be synchronized on the set once (for 8 hours) on the camera's Timecode or constantly supplied with Timecode by the camera. The camera then takes on the master clock function.

The 416 TC Generator is not able to adjust the clock of an external device to its own clock frequency. When using the 416 TC Generator as a master clock the adaptation to the master clock has to be done by the slave itself. No functionality is provided by the 416 in this respect.

Timecode and ESU-1

When using the external synchronization unit ESU-1 for synchronizing the camera to other equipment, Timecode can still be recorded. The difference between the external synchronization and the TC frame rate must be less than 1%. If the difference exceeds 1% the TC recording switches off and the "TC" symbol in the display goes off. If the speed comes back to within 1% of the TC frame rate, TC recording switches on again and the "TC" symbol appears again on the display. Even if an external synchronization unit is used, it is necessary to set the expected frame rate on the camera, before attaching the ESU-1.

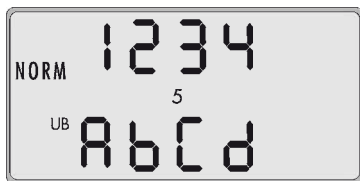
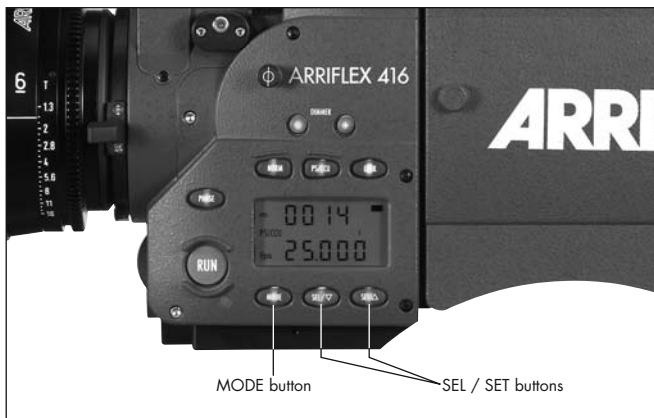

Using Timecode



For Timecode operation, please make sure that the magazine is equipped with a Timecode exposure module K2.55034.0.

Turning on and off the TC Recording

- Using the "MODE" key ⇒ **photo**, switch to Mode 4 (Timecode time).
- Depress the "SET" key ⇒ **photo** for approx. 3 s until the "TC" symbol appears or disappears on the display.

When the camera is first turned on without a previously set valid Timecode remaining in the buffer, the Timecode clock starts running from time 00:00:00:00, with the User Bits set to 00000000. This happens regardless of whether TC is turned on or not. TC time can only be set by the master clock. User Bits can be set either by the master clock or entered manually with the camera display. If TC is turned on but not set by external synchronization, a warning will be displayed.

If a speed is set on the camera which does not correspond to TC, the TC generator retains the most recently set frame rate. While Timecode is in use and the speed is changed from one to another valid Timecode speed, the "TC" symbol on the display goes off for approx. 1 s and reappears once the TC generator is ready.

When TC is set at a Real Time frame rate (24 fps, 25 fps & 30 fps) and the camera speed is changed to a Non Real Time Frame rate (23.976 fps & 29.97 fps), a warning will be indicated after the camera has stopped. The same warning comes up if you set a TC at Non Real Time frame rate and switch to Real Time frame rate afterwards. Setting the TC at the used frame rate (Non Real Time or Real Time) has to be done to clear this error.

While TC recording is switched on and the camera is running, there is a delay of approx. 24 frames before the camera stops after the "RUN" button is pressed to stop the camera.

Entering User Bits with the Camera Display

- Using the "MODE" key ⇒ **photo** switch to Mode 5 (Timecode User Bits).
- Use the "SEL" key ⇒ **photo** to select the digit you wish to change. The selected digit will flash.
- Use the "SET" key ⇒ **photo** to change the value of the selected digit.

Note: User Bit values are hexadecimal so only values from 0 - 9 and A - F are available.

Indicating Timecode or User Bits

- Using the "MODE" key switch to Mode 4 (Timecode time) or Mode 5 (Timecode User Bits).

The Timecode time indicator will indicate "hours:minutes" in the upper line and "seconds:frame rate" in the lower line. In the case of frame rate, only positions before the comma will be shown:

23	23,976 fps
24	24,000 fps
25	25,000 fps
29	29,970 fps
30	30,000 fps

At speeds of 29,970 fps and 23,976 fps the frame rate in the "Nondrop-Frame" mode count in accordance with SMPTE RP136-1990, 5.2.1, to correspond to NTSC video with 59,940 Hz. The "Nondrop-Frame" mode results in a time difference to real time of exactly 0,1%.

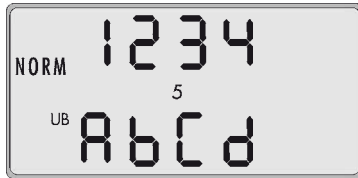

Overview of the Display Indications used in Timecode Operation

TC-Indication on the Display

The "TC" symbol has the following meanings:

Timecode symbol (TC) solid	Timecode is set and will be recorded when the camera is running
No timecode symbol (TC)	Timecode recording is turned off
Timecode symbol (TC) blinks in Standby	Any TC Warning (see next section) (e.g. Timecode was last set or external synchronization was last performed over 8 hours ago) Note: If the last setting or synchronization was over 8 hours ago timecode can still be recorded for test purposes
Timecode symbol (TC) blinks while the camera is running	Timecode is not being recorded on the film because of a functional disturbance

TC Warnings

A TC warning is displayed firstly as a blinking “TC” symbol in the camera display. If the beeper volume is set to 1 or higher, a warning beep will sound in time with the blinking of the “TC” symbol when the camera is in Standby. The acoustic warning can be silenced by doing one of the following:

- Remedy the cause of the warning.
- Switch off timecode.
- Set the beeper volume to 0 (see under Switching the Beeper On and Off, Chapter 9.3).
- By briefly pressing the “SET” button in Mode 1 of the display. This will suppress the acoustic warning for 15 minutes.
- Running the camera. The acoustic warning will not sound while the camera is running. After stopping the camera the warning will begin to sound again approximately 3 seconds after the camera enters Standby.

The camera can also display more detailed warnings in hexadecimal form. To see these, change the display to Mode 4 (Timecode time) using the “MODE” button and then press the “SEL” button.

The four digits in the upper line display hexadecimal values (0 - 9 & A - F). Their meaning can be looked up in the following tables. There is no warning if the upper line displays 00:00. An example of an error warning is 00:03, which indicates two warnings:

- error in external synchronization and
- TC is switched on but not set

In this case both errors can be remedied by external synchronization.

Upper Line 1st Digit for TC Warnings																Warning	Remedy
0	1	2	3	4	5	6	7	8	9	A	b	C	d	E	F		
	•		•		•		•		•		•		•		•	no valid TC frame rate	set correct TC frame rate or switch off TC
		•	•			•	•			•	•			•	•	no meaning on 416	N/A
				•	•	•	•					•	•	•	•	no meaning on 416	N/A
								•	•	•	•	•	•	•	•	the last take has no or intermittent TC	briefly depress the „PHASE“-button, or reshoot

Upper Line 2nd Digit for TC Warnings																Warning	Remedy
0	1	2	3	4	5	6	7	8	9	A	b	C	d	E	F		
	•		•		•		•		•		•		•		•	more than 8 hours since TC was last set	reset TC
		•	•			•	•			•	•			•	•	TCS values not valid	reset TCS value
				•	•	•	•					•	•	•	•	ESU frame rate outside TC range	check ESU frame rate (display Mode 1) and TC generator frame rate (Mode 4); max. allowable difference is 1 %
								•	•	•	•	•	•	•	•	no TC with variable speed	switch off variable speed accessory or TC as TC-operation with variable speed is not possible

Upper Line 3rd Digit for TC Warnings																Warning	Remedy	
0	1	2	3	4	5	6	7	8	9	A	b	C	d	E	F			
	•		•		•		•		•		•		•		•		no meaning on 416	N/A
		•	•			•	•			•	•				•		TC not set to NDF/RT and switched to RT/NDF	reset TC at current frame rate RT (Real Time) is 24, 25, 30 fps NDF (Nondrop Frame) is 23,976 and 29,97 fps
				•	•	•	•						•	•	•		TC LED not recognized	fit or check TC module
								•	•	•	•	•	•	•	•		TC not buffered	reset TC; either the TC buffer capacitor was not (yet) charged or the power supply was insufficient or interrupted

Upper Line 4th Digit for TC Warnings																Warning	Remedy	
0	1	2	3	4	5	6	7	8	9	A	b	C	d	E	F			
	•		•		•		•		•		•		•		•		error in external synchronization	resynchronize or check LTC-signal
		•	•			•	•			•	•				•		TC switched on but not set	set TC
				•	•	•	•						•	•	•		TC not ready	functional error have the camera checked at an authorised ARRI Service Centre

Film stock	Type	TCS Value
Fuji 8622	(Color Negative)	6
Fuji 8632	(Color Negative)	6
Fuji 8652	(Color Negative)	5
Fuji 8653	(Color Negative)	6
Fuji 8662	(Color Negative)	4
Fuji 8663	(Color Negative)	5
Fuji 8672	(Color Negative)	4
Fuji 8673	(Color Negative)	5
Fuji 8682	(Color Negative)	6
Fuji 8683	(Color Negative)	6
Fuji 8692	(Color Negative)	4
Kodak 7201	(Color Negative)	7
Kodak 7205	(Color Negative)	6
Kodak 7212	(Color Negative)	6
Kodak 7217	(Color Negative)	6
Kodak 7218	(Color Negative)	5
Kodak 7222	(B/W Negative)	8
Kodak 7229	(Color Negative)	5
Kodak 7231	(B/W Negative)	8

Film Sensitivity (TCS Value)

The intensity of the TC recording must be adjusted to suit the sensitivity of different film stocks. The switch for setting the TCS level (Timecode sensitivity) is on the feed side on the magazine. The knob can be turned by hand if the magazine door is open or with a small screwdriver if the magazine door is closed.

“0” means no recording, “1”-“9” stand for the various intensity levels. The higher the TCS level, the higher the intensity of the recording. The difference in intensity of the successive TCS levels corresponds to one aperture stop. The currently set level can also be seen in Mode 4 on the display by pressing the “SEL” key.

The TCS levels of the most frequently used film types are listed in the table or are available from the ARRI website.

Indicating Clock Adjustment

If the 416 TC generator has been adjusted to an Ambient Clockit the capital letter "A" is displayed next to the TCS value in the second line of Mode 4 by pressing the "SEL" key.

A manual reset to default clock can be initiated by

- Using the "MODE" key, switch to Mode 4 (Timecode time).
- Depress and hold the "SEL" key.
- Depress the "SET" key for approx. 3 sec. until the letter "A" disappears on the display.

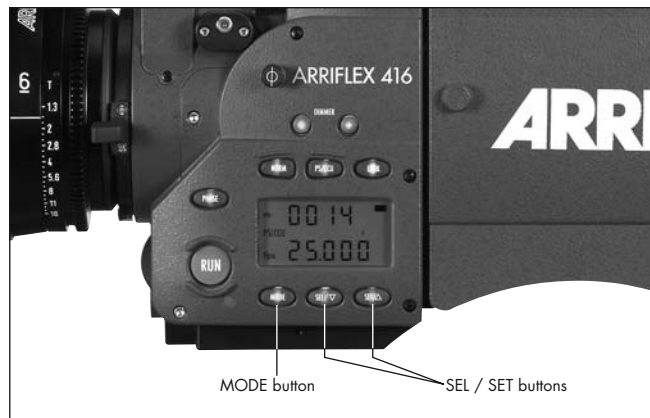

TC Buffer

The ARRIFLEX 416 ensures not only high accuracy of the Timecode but also allows the TC clock to continue running while the camera is switched off as long as the camera is connected to a power supply. The TC generator needs a power supply of 10mA when the camera is switched off.

To allow the camera battery to be changed, a short-term buffer of one minute is provided by charge stored in a capacitor. In order for this buffer to function however it is necessary that the camera be connected to a power supply for at least 10 minutes to allow the capacitor to charge prior to a battery change. Have a fresh battery ready before disconnecting the old one.

To enable the camera to be used while mobile without losing TC time, the use of an on-board battery is recommended. An on-board battery can power the TC buffer for more than 100 hours. To reduce power consumption while working with the battery, the battery should be removed during lengthy breaks in filming (longer than a day). Before recommencing filming, TC synchronization will need to be carried out again.

12. ARRIFLEX 416 Plus

12.1 General Description

The ARRIFLEX 416 Plus has an extended electronic side cover that offers the following additional functions over the standard ARRIFLEX 416:

- Built-in radio modem for wireless remote control of lens and camera.
- Motor drivers for up to three CLM-2 motors.
- Two LCS bus interfaces for CLM-1, WHA-2 and ZMU-3.
- LDD (Lens Data Display) interface.
- A second "RS" socket.

The ARRIFLEX 416 electronic side cover is easily exchanged with the extended version to convert it into an ARRIFLEX 416 Plus and vice versa. This is a workshop procedure and should be carried out at your rental facility or local ARRI Service Centre.

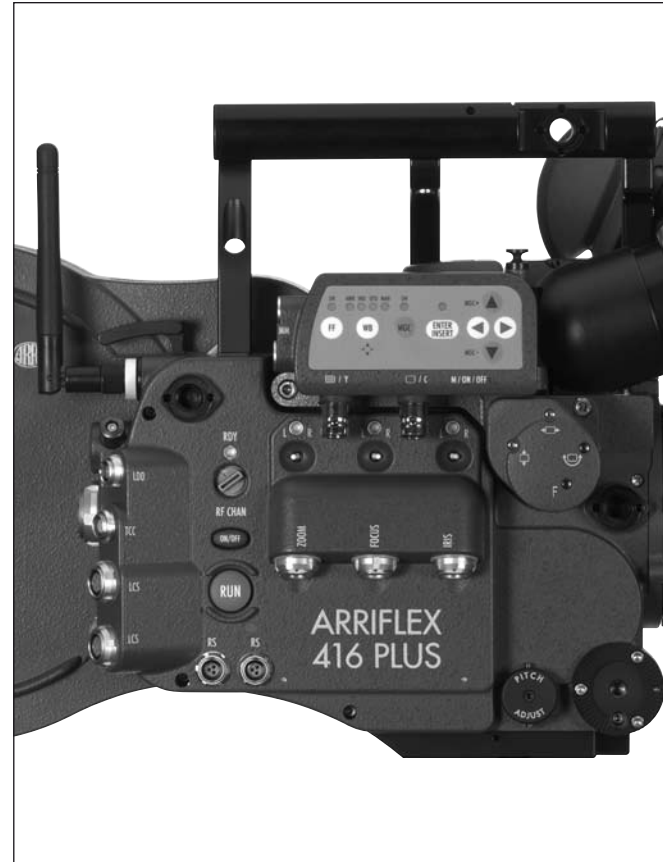

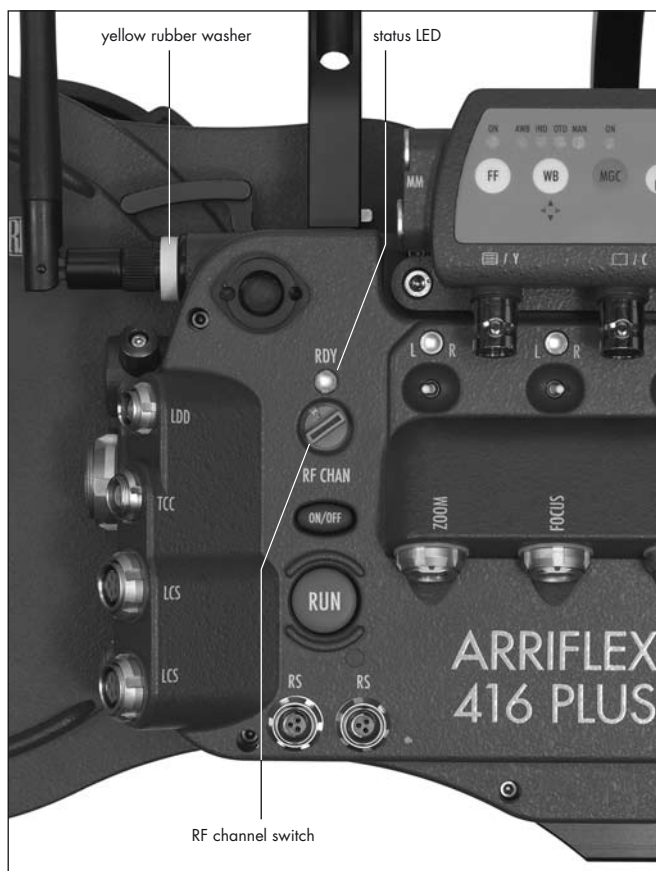

12.2 Radio system

A radio is incorporated into the 416 Plus extended electronics. This enables wireless communication of lens control and lens data information as well as remote control of the camera functions.



*The 416 Plus uses the latest ARRI WRS protocol which is denoted by a yellow rubber washer on the antenna ⇒ **photo**. All ARRI WRS products can be upgraded to the new protocol – consult your local ARRI Service Centre.*

The 416 Plus has a channel selection switch and a status LED ⇒ **photo** for the radio modem. The channel selection switch on the camera should be set to the same number as that of the WMU-2/3 used on the controlling handset.

It is not possible to control more than one 416 Plus, URM, UMC-3 or LDB with one Wireless Main Unit simultaneously.

Yellow washer wireless protocol uses a specific scheme of changing frequencies to make the connection between the handset and camera modems more robust. The channels of the selection switch are allocated as follows:

Channel	Use
0	2444 - 2472 MHz
1	2406 - 2435 MHz
2	2444 - 2472 MHz
3	2406 - 2435 MHz
4	2444 - 2472 MHz
5	2406 - 2435 MHz
6	2444 - 2472 MHz
7	2406 - 2435 MHz
8	Not used
9	Radio device deactivated

Note: If two yellow washer remote systems are on the same set, it is recommended to set one system to an even channel and the other to an odd channel.



Only odd numbered channels are legally permitted for use in France

To change the radio channel:

- With the camera off, set the channel and then turn the camera on. Or,
- Move the channel selection switch to 9 (deactivated) and then turn it to the required channel within half a second. Or,
- Set the channel selection switch on the camera to the new channel – the RF LED goes red. Then turn the camera off and back on again after approximately 5 seconds.

The RDY LED of the radio system ⇨ **photo** indicates the status of the radio as follows:

LED Color	Status
Off	Wireless deactivated (channel 9 selected) or camera deactivated or camera has no power
Alternating red/green	Radio modem is being initialised. Do not activate the WMU yet.
Green blinking	Radio modem is ready, activate the WMU
Green	Wireless remote control OK
Red	Channel selection switch has been changed. Wireless remote control will continue to function but the channel will be changed the next time it is switched on. -> Reset to the previously selected channel if the change was unintentional, or turn module off and on again to change channel.
Red blinking	Hardware error in radio module. If this error persists after restarting the camera, send the camera for service.
Red blinking rapidly	Radio fault: another ARRI wireless system is on the same channel nearby. Select another channel.

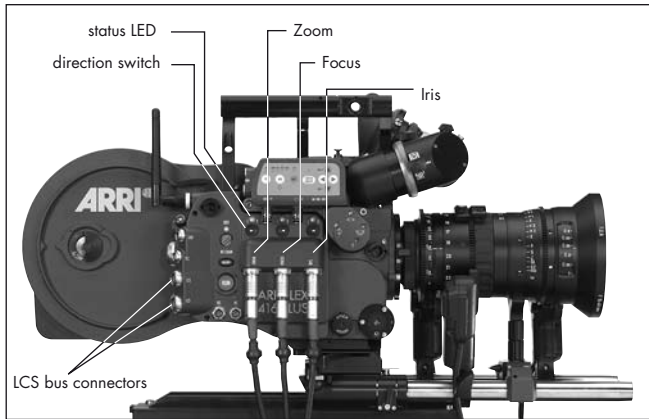

12.3 Wireless Remote System

Lens Motors

Both CLM-1 and CLM-2 motors can be used with the ARRI FLEX 416 Plus.

- CLM-1 motors should be daisy-chained in series with one of the end motors connected to either (but not both) of the 416 Plus LCS bus connectors ⇒ **photo**.
- CLM-2 motors should be connected, according to their position on the lens, to the Zoom, Focus and Iris connectors of the 416 Plus ⇒ **photo**.
- CLM-1 and CLM-2 motors may be used simultaneously but only on different lens axes.

In the situation where a CLM-1 is assigned to Focus and a CLM-2 is simultaneously plugged into the Focus connector, the CLM-1 will have priority and the CLM-2 connection will be deactivated. The same applies to the Zoom and Iris axes.

Each CLM-2 motor connection has a direction switch ⇒ **photo** and a status LED ⇒ **photo**.

- Use the direction switch to change the direction of rotation of the attached motor.

The status LEDs indicate the following:

Color	Status
Off	no motor connected
Red	motor connected but no control unit found
Green	motor OK
Green blinking	motor OK but at an end stop
Red blinking	motor conflict: CLM-1 assigned to same function
Red/green alternating	calibrating

The following pages show some possible setups of the LCS and WRS systems. These are only examples and further variations are possible. See the Lens Control System Instruction Manual for more details.

Cables LC-M1, LC-M2, LC-Z1 and LC-Z2 are interchangeable and differ only in appearance and length.

Cable	Appearance
LC-M1	Coiled, 1 m long outstretched
LC-M2	Straight, 0.5 m long
LC-Z1	Straight, 3.5 m long
LC-Z2	Straight, 7 m long

WMU-3, WBU-3, WFU-3 and CLM-2 Motors

WBU-3 + WMU-3 + WFU-3 - Iris & Focus



CLM-2 Iris CLM-2 Focus

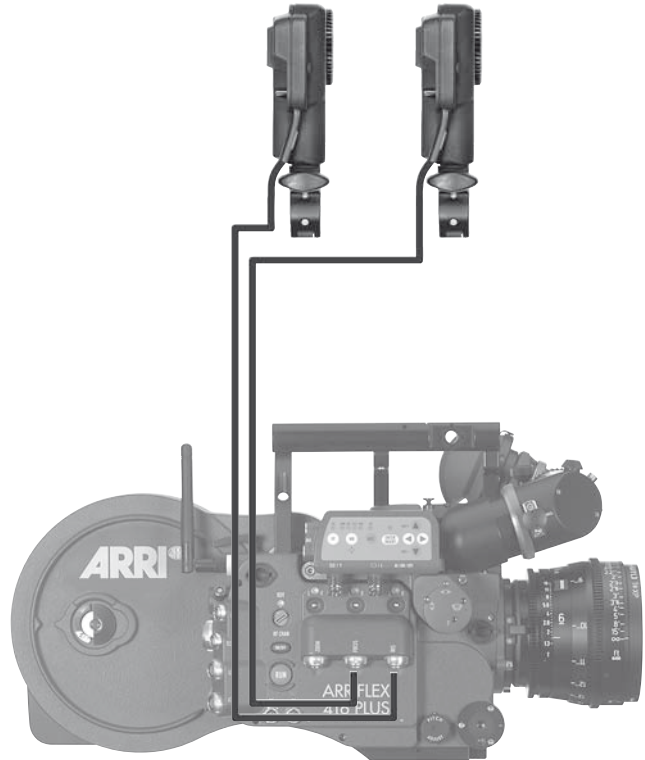

2 x WMU-3, WBU-3, WFU-3 and CLM-2 Motors



WBU-3 + WMU-3 + WFU-3 - Focus



WBU-3 + WMU-3 + WFU-3 - Iris

CLM-2 Iris

CLM-2 Focus

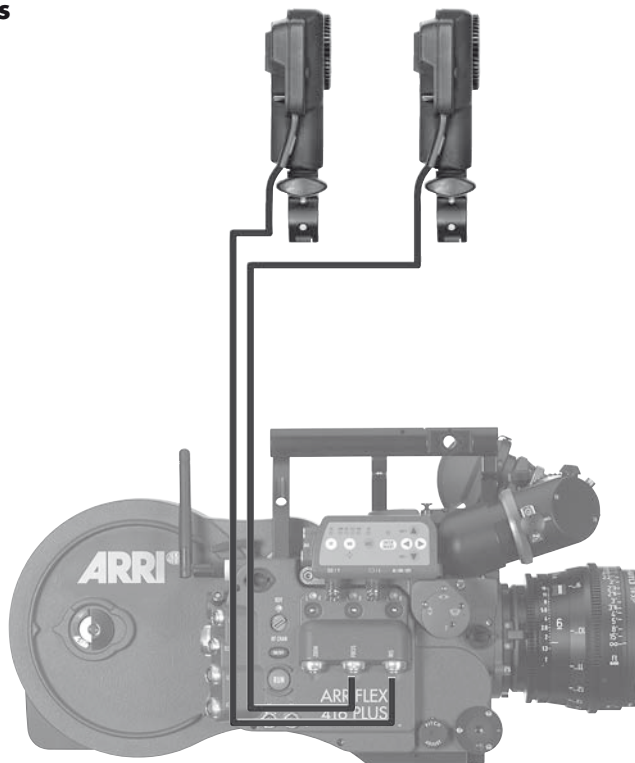

ZMU-3, WMU-3, WBU-3, WFU-3 and CLM-2 Motors

WBU-3 + WMU-3 + WFU-3
Focus & Iris



ZMU-3
Zoom



CLM-2 Iris

CLM-2 Focus

CLM-2 Zoom

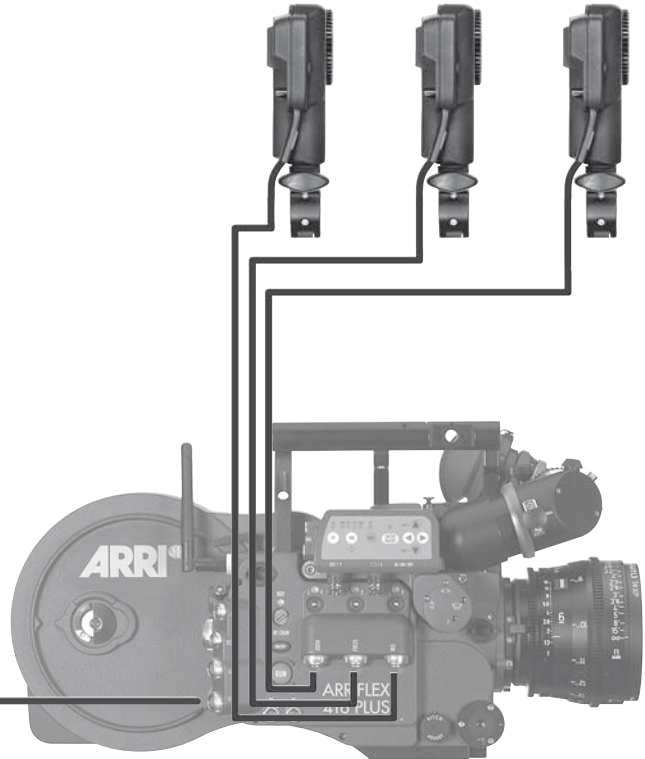

**ZMU-3, WZB-3, WBU-3, WMU-3 and WFU-3
with CLM-2 Motors**

**ZMU-3, WZB-3, WBU-3 + WMU-3 + WFU-3
Zoom, Focus & Iris**



CLM-2 Iris CLM-2 Focus CLM-2 Zoom

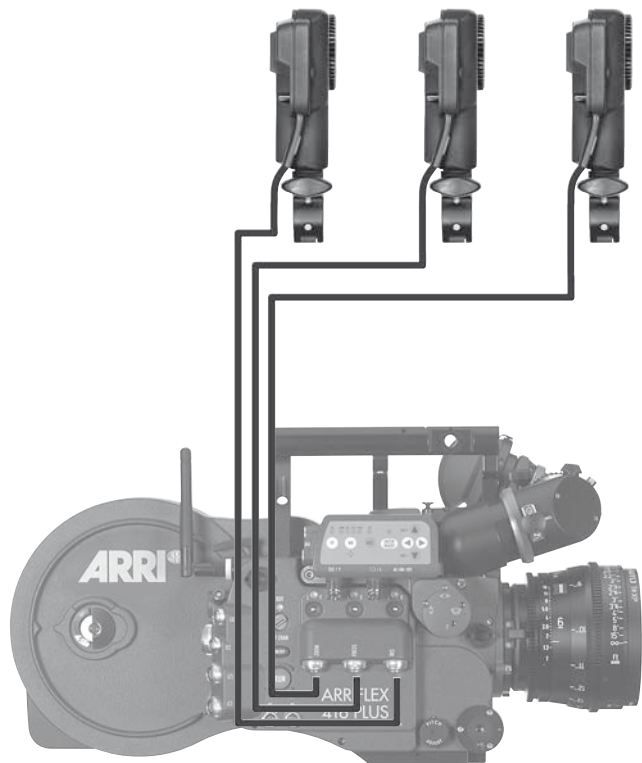

WHA-2, WFU-3, WZB-3, ZMU-3 and CLM-2 Motors

WHA-2 + WFU-3
Focus & Iris



ZMU-3
Zoom

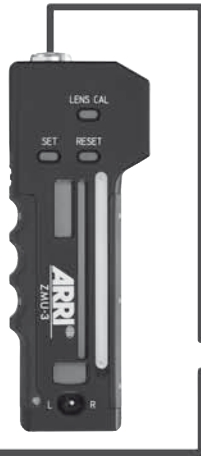

CLM-2 Iris

CLM-2 Focus

CLM-2 Zoom

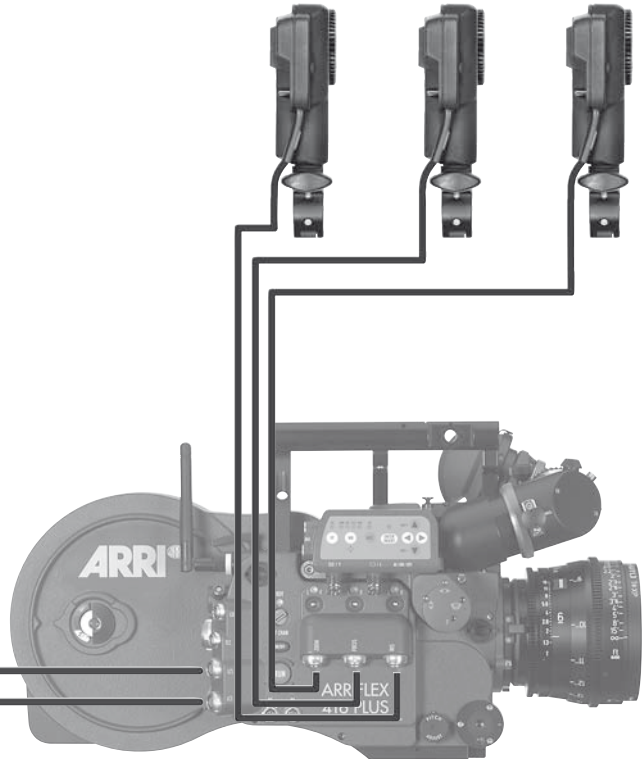

**ZMU-3, WZB-3, WBU-3, WMU-3, LDD-FP,
WEB-3, WFU-3 and CLM-2 Motors**

ZMU-3, WZB-3, WBU-3, WMU-3, LDD-FP, WEB-3, WFU-3
Zoom, Focus, Iris and LDD-FP



CLM-2 Iris CLM-2 Focus CLM-2 Zoom

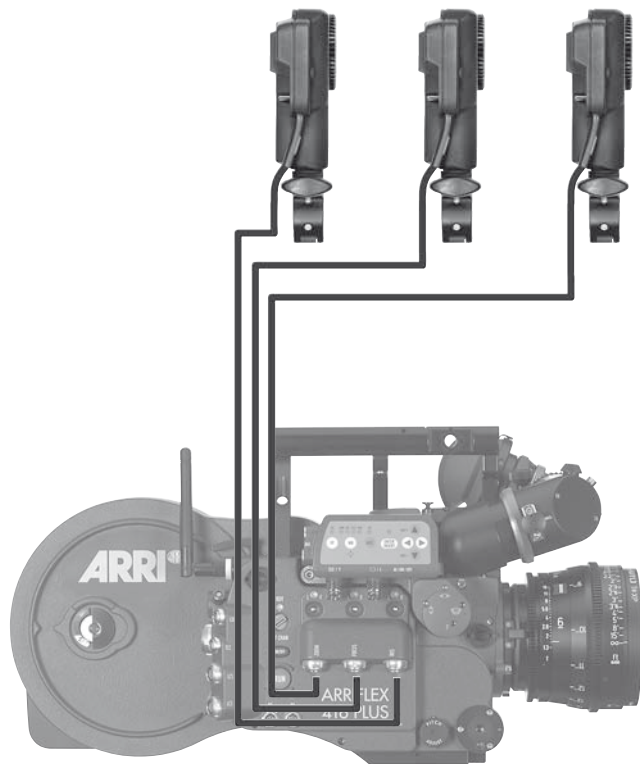

12.4 Camera Remote Control

Note: For details of how to use the RCU-1, WRC-1 and ESU-1, please see the instruction manuals supplied with these units.

The 416 Plus can be remotely controlled by cable and via wireless remote control.

Only one camera control unit may be used with the 416 Plus at any one time. More than one WMU-3 can be used in parallel.

If the WRC-1 is used to control the camera either wireless (with WMU-2/3) or with a cable to the LCS bus (with WHA-2/3), the CCU LED turns from green to red to indicate that the REMOTE connector is not available.

The following pages show some examples of remote control setups:

If RCU/WRC and ESU are used in parallel they can be connected to the "REMOTE" socket via the splitter cable KC-88-5.

WRC-1 via wireless remote control



WRC-1 + WMU-3

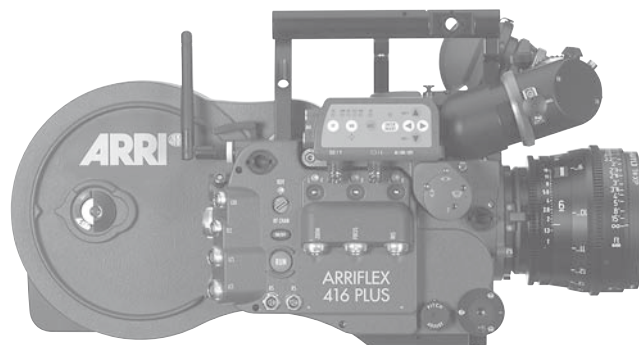

WRC-1 with WHA-2 via cable

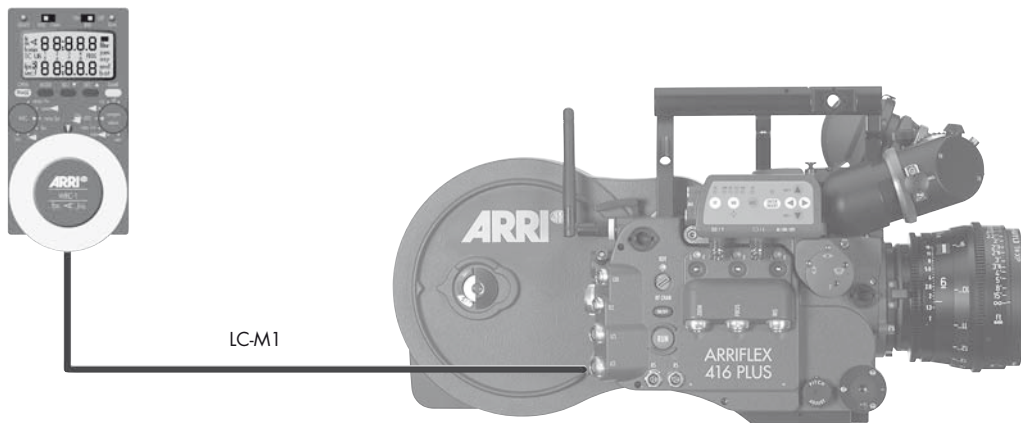

WRC-1 + WHA-2

WRC-1 with WHA-1

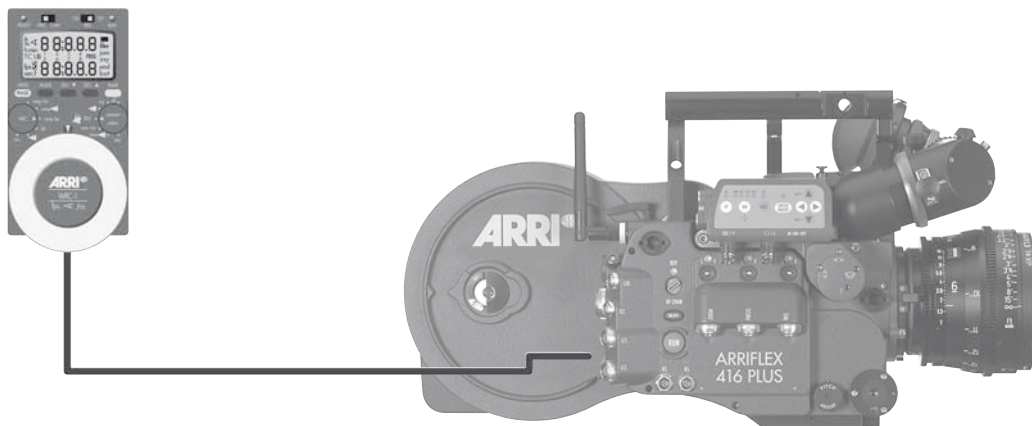

WRC-1 + WHA-1

RCU-1

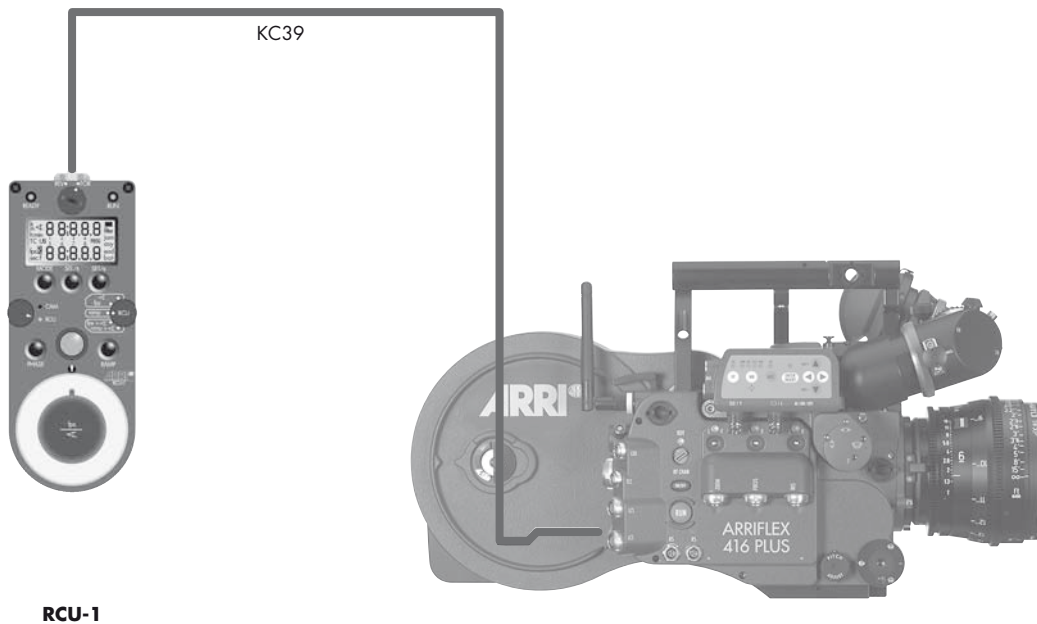

12.5 Lens Data Display

Compatibility

The ARRIFLEX 416 Plus can be used with the Lens Data Display for Focus Puller (LDD-FP) to display lens information using the Lens Data Archive. LDS contacts are not fitted to the camera's lens port so LDS lenses and the LDS Data Mount are not supported.



The ARRIFLEX 416 Plus is only compatible with the Lens Data Display for Focus Puller (LDD-FP). The Lens Data Display Classic (LDD) is not supported.

The LDD-FP can be operated with the 416 Plus in either of the following configurations:

- Cable LDDFP-RDO (K2.54172.0) between the LDD connector on the camera and the LDD-FP for cable operation.
Or
- Wireless, mounted on the WMU-3.

Lens Data Archive

The Lens Data Archive provides the key LDS features for any camera with any lens, as long as the LDD-FP, UMC-3 or 416 Plus and CLM-1 or CLM-2 lens motors are used – manual follow focus is not supported. After each lens change, the lens type is selected from a pre-programmed menu on the LDD-FP.

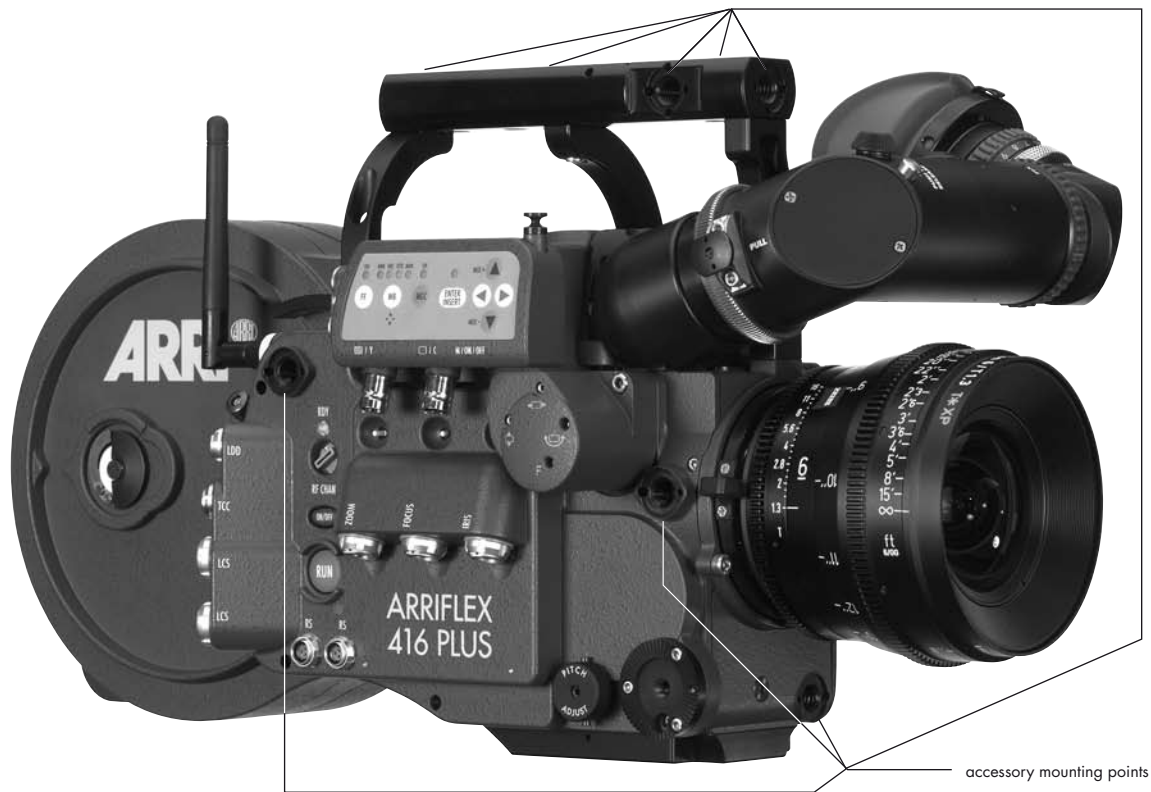

accessory mounting points

13. Accessories

Accessory Mounting Points

On the camera body and on the electronic cover there are accessory mounting points. Various accessories can be mounted to them by using 3/8-16 screws.



*Check that the screws do not reach more than 9mm into the camera body from the contact surface ⇒ **photo**, otherwise the camera may be damaged.*

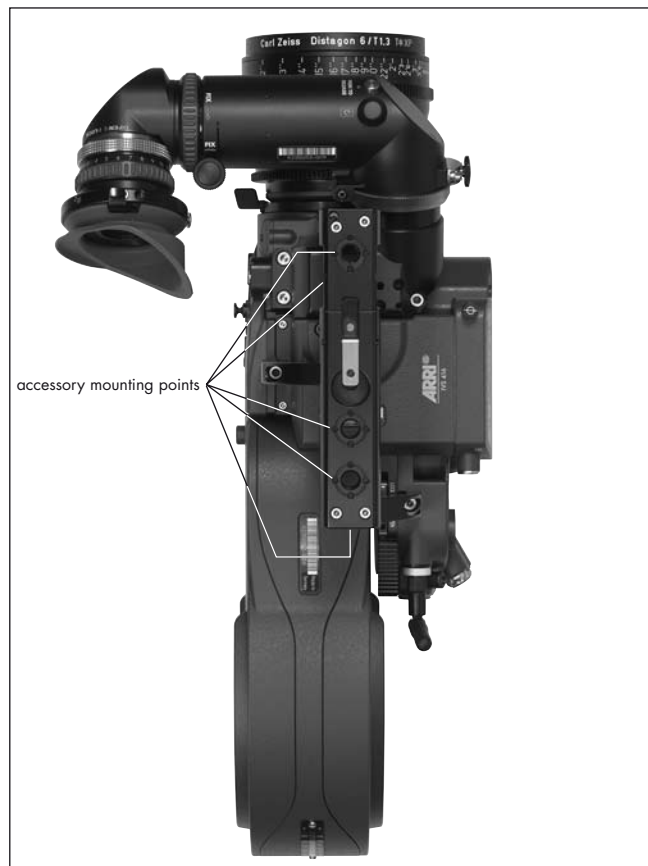



Work Light WL-3

- Screw the work light into the Accessory Rosette.
- Connect the plug to an “RS” socket.
- Bend the flexible arm, to bring the work light into the desired position. The work light can be turned on and off with the ring on the lamp head ⇒ **photo**. The brightness of the work light can be adjusted with the mechanical shutter.

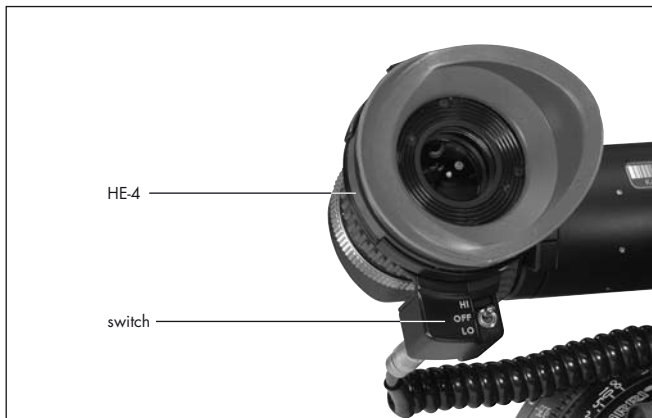

Heated Eyecup HE-4 & HE-5

The heated eyecup prevents the eyepiece ⇒ **photo** from misting-up, e.g. when filming outdoors in cold weather.

- Pull the normal eyecup off the eyepiece and replace it with the heated eyecup.
- Connect the heated eyecup to the heated eyepiece outlet with cable KC-63.
- Set the heating level with the toggle switch ⇒ **photo**:
 “LO”: low heat output
 “HI”: higher heat output.



If the camera and accessories are powered by battery, switching off the eyecup during extended breaks in filming will help conserve power.

Remote "RUN" Switch RS-4

- Attach the remote "RUN" switch with the spring clamp ⇒ **photo** (e.g. to the pan handle).
- Plug the RS-4 plug into an "RS" socket.

The RS-4 cable can be extended by 3m/9ft by use of the KC-40 Extension Cable (K2.47207.0)





External Synchronization Unit ESU-1

The external synchronization unit ESU-1 ⇒ **photo** can be used with the ARRIFLEX 416 as well as with the 235, the 435 models, 535, 535B and 16SR 3/Advanced. It allows the camera to be synchronised to other equipment such as TV monitors. By means of a BNC-socket, it is possible to synchronize to an external standard video signal (50/60 Hz) or, through an inductive pickup, to a CRT type monitor. The camera display shows "ESU" in the upper line. The ESU-1 can be used for frame rates from 3 to 60 fps.

The frame rate is indicated on the camera display in Mode 2. A phase shifter and a pilot tone generator have also been integrated into the external synchronization unit. The phase relationship of the synchronization is retained even when the camera is switched off.

See TECHN. INFORMATION "External Synchronization Unit ESU-1".

- To connect the ESU cable to the camera, the 235/416 Accessory Expansion Cable KC-88-s has to be connected to the camera's "REMOTE" socket. The ESU cable is then connected to the accessory expansion cable. The RCU-1 can be connected to the other socket of the accessory expansion cable.

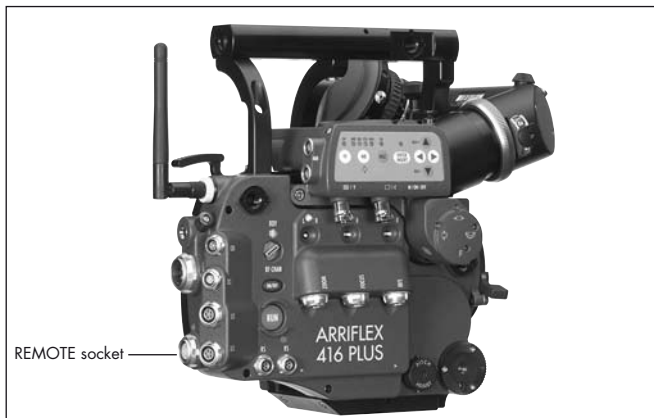

Remote Control Unit RCU-1

The RCU-1 ⇨ **photo** is a practical remote control unit for use with all of the latest generation ARRIFLEX camera models. It can be used in all applications that call for an uncomplicated, quick, sturdy and yet still comprehensive remote control.

Complete programs can easily be created to control changing of frame rate over a certain period of time. These programs are repeatable and can be recalled as necessary. The RCU-1 automatically calculates the actual screen-time for the programmed speed ramps. running values can be regulated with the large hand wheel.

The free programming of individually defined minimum and maximum values as end stops is particularly useful.

The illuminated LCD quickly, precisely and comprehensively shows all set values as well as the status of the camera, or the RCU-1 respectively, including all warning signals.

- The RCU cable is connected to the "REMOTE" socket ⇨ **photo** on the camera.

For further information see the RCU-1 instruction manual.

Note: CCU, RU and LCC are not supported and could cause malfunction if connected.



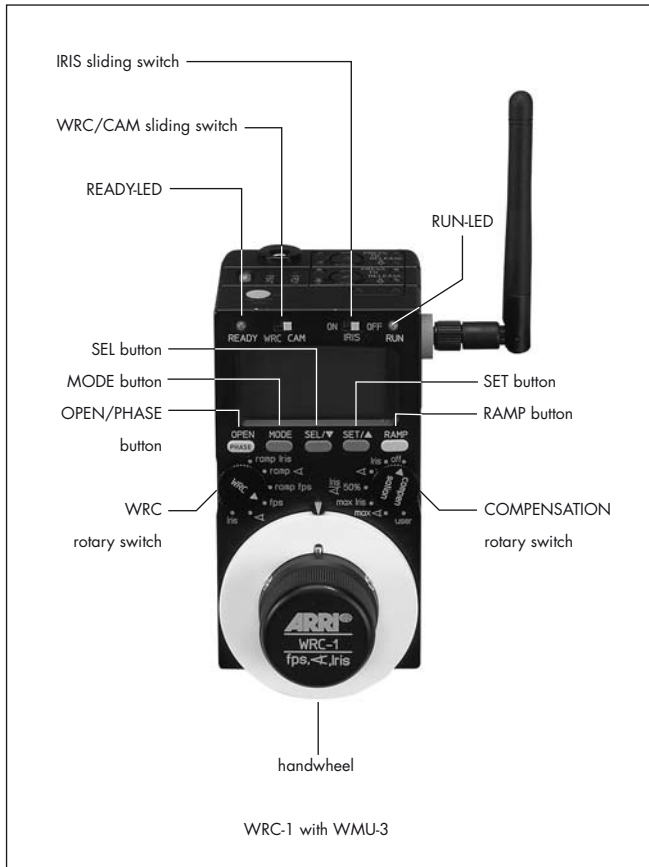

Wireless Remote Control WRC-1

The Wireless Remote Control WRC-1 is a handy remote control unit for use with all of the latest generation of ARRIFLEX camera models: ARRIFLEX 16SR 3/Advanced, 16SR 3 HS/Advanced, 535, 535B, 235, 435ES, 435 Advanced, 435 Xtreme and the ARRIFLEX 416.

On the ARRIFLEX 416 it enables the user to remotely control:

- the camera speed,
- the aperture of the lens (iris),
providing constant exposure compensation for speed ramps.

The range of functions offered by the WRC-1 is automatically adapted to the limits of the camera and the lens control motor which it is controlling. The large hand wheel permits sensitive adjustment of operational values, and easy programming of end-stops for user-defined minimum and maximum values.

The illuminated LCD provides quick, precise and comprehensive information about all the settings, the status of the camera and the WRC-1, including all warnings.

The WRC-1 is the perfect addition to the ARRI Wireless Remote System. Connected to the Wireless Main Unit (WMU-2, WMU-3) it enables all functions to be remotely controlled. The WRC-1 can also be connected to the camera via cable using the Wireless Handgrip Attachment WHA-2. However, the lens remote control functions are not available in this configuration.

14. Maintenance

When maintaining and cleaning the camera and accessories, pay careful attention to the following notes and tips:

- Always disconnect the camera from the power supply.
- Clean the camera and accessories only on a clean and flat surface which is covered with foam material or a clean, lint-free cloth.
- Under no circumstances use acetone or nitro-thinner. These chemicals dissolve the paint and can damage highly-polished surfaces and plastic parts.
- For cleaning, the use of soft, lint-free cloths and swabs is recommended. Also suitable are special cleaning tissues and small sponges as used in cleaning computers and video equipment.
- When cleaning the film movement, do not exert too much pressure. Use only the prescribed special tools. Use only good quality screwdrivers of the correct size.
- From time to time – at the very least after the occurrence of a film jam – it is recommended to clean the entire interior of the camera and also the magazine throat and the film gate with a brush. In most cases it is sufficient to vacuum out dust and film chips from the camera and the magazine interiors. A small battery-powered vacuum cleaner, as used in cleaning computers, is suitable for this task.



Camera

Cleaning the Film Gate

Loose dust or dirt leads to a layer of emulsion forming on the film gate. This can cause scratches on the film and can also lead to a change in the film's coefficient of friction.



Attention!

Keep fingers out of the film gate opening as this may damage the mirror shutter.

To clean the film gate

- Remove the layer of emulsion from the film gate with a plastic rod (e.g. the ARRI film gate cleaner). Under no circumstances use hard or metal objects.
- When cleaning, pay particular attention to the area of the film gate opposite the magazine pressure plate if film stock with a strong tendency to build up emulsion (e.g. b/w stock) is being used.

Cleaning the Field Lens

- Briefly press the "PHASE" button, to position the shutter to protect the mirror surface from damage as far as possible.
- Before cleaning the field lens, switch the camera's main switch off and disconnect from the power supply!
- Remove the lens or the protective cap from the camera's lens port.



Do not touch the mirror surface!

- Pull the fibre screen ⇒ **photo** out of the holder by its tongue ⇒ **photo** using the special forceps.
- Pull the field lens ⇒ **photo** out of the holder by its tongue ⇒ **photo** using the special forceps.
- Clean the field lens with a dry, lint-free cloth.
- Make sure that the frame is completely clean.
- Using the special forceps, push the field lens as far as it will go into the holder. A sprung-ball catch fixes the field lens in the correct position.
- Check that the fibre optic screen and its frame are completely clean.
- Using the special forceps, push the fibre optic screen into the holder as far as it will go. A sprung-ball catch fixes the fibre optic screen in the correct position.

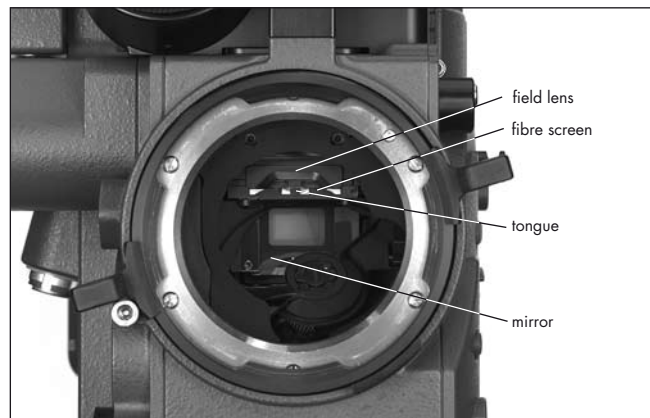

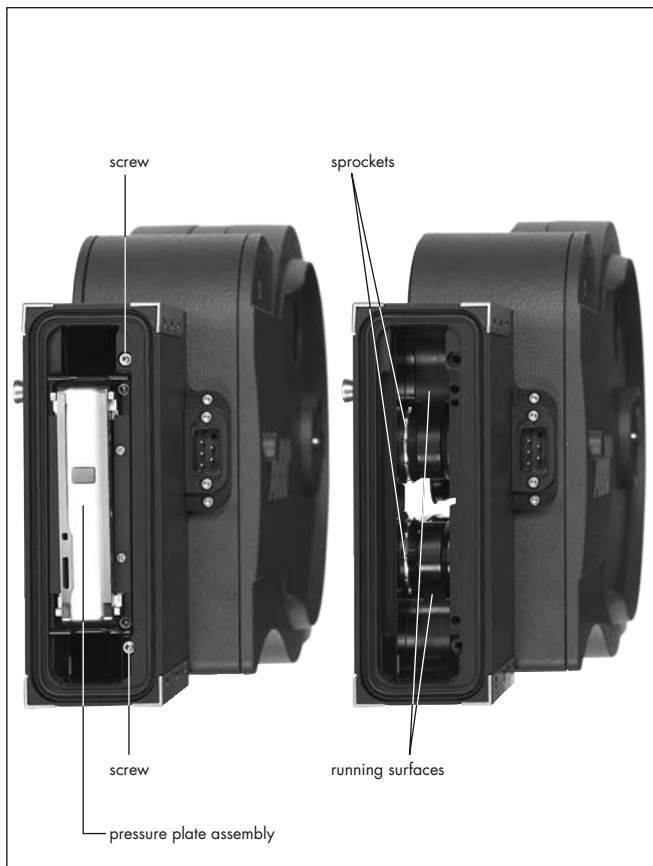

Magazine

Cleaning the Throat Assembly

The magazine throat assembly ⇒ **photo** can be disassembled for cleaning.

- Remove the two screws beside the top and bottom corners of the pressure plate ⇒ **photo**.
- Open the take-up side door and fully loosen the screw between the two sprocket rollers ⇒ **photo**.
- Flip the magazine over so the screw drops out of engagement with the pressure plate assembly. The screw is captive so it will not fall out and get lost ⇒ **photo**.
- Pull out the pressure plate assembly ⇒ **photo**.
- Clean the film running surfaces ⇒ **photo** and guide rollers ⇒ **photo** with a brush.
- Put the pressure plate assembly back in place. (It fits accurately on dowel pins).
- Refit and tighten the two screws.

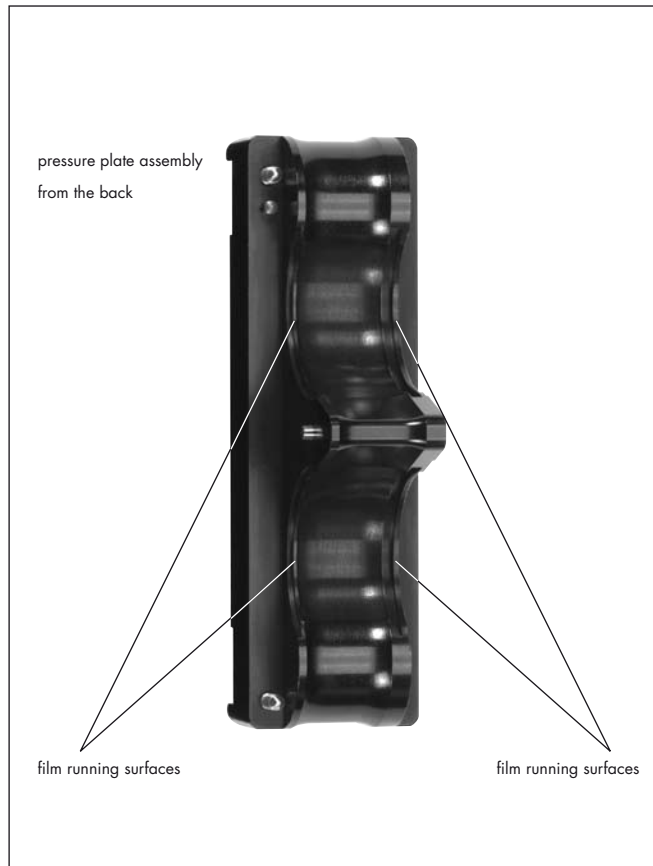
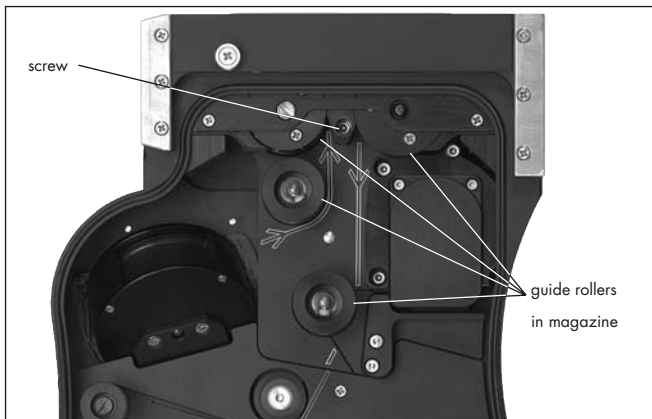
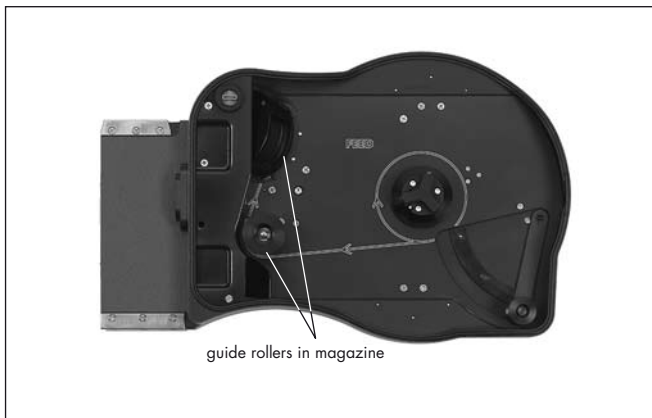

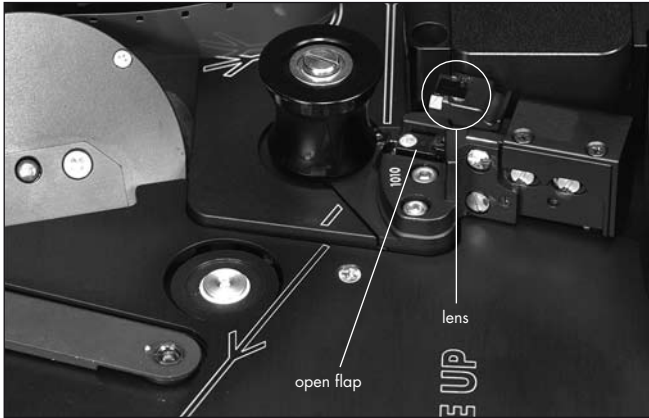
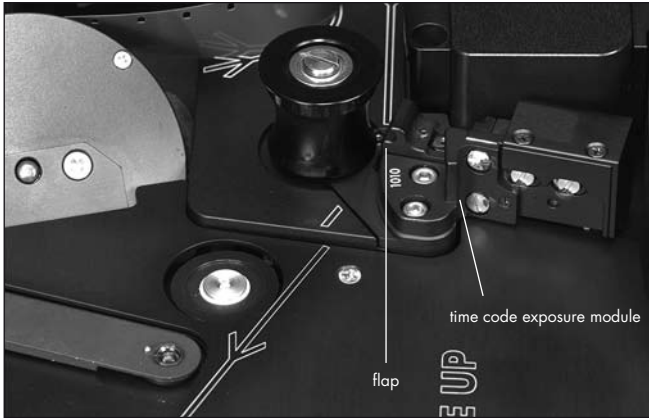

Timecode Exposure Module



For Timecode operation, make sure that the lens of the exposure mode is clean.

- To clean the lens, swing it out as shown ⇒ **photo** and clean it.
- Make sure that there are no foreign objects, e.g. film dust beneath the flap ⇒ **photo**.

15. Appendix

The frame rate of the camera is constantly monitored while it is running. If the actual frame rate deviates from the set frame rate, the operation control indicator glows red, a red LED is seen in the viewfinder and the camera display shows the warning for asynchronous running ("asy").

Fuses

The ARRIFLEX 416 is equipped with self-resetting automatic fuses. There are no conventional fuses to blow.

If one of the self resetting fuses blows, turn the camera off, unplug all accessories from the camera, wait for one minute, and turn the camera back on.

Error text in display	Error text in IVS	Problem
Error LooP.S	Magazine film loop too short	magazine film loop too short
Error LooP.L	Magazine film loop too long	magazine film loop too long
Error CntL	Controller Error	internal controller limits have been exceeded, check if camera is jammed
Error CASS	Magazine error	
Updt PC	software update in progress	camera software and firmware is updated
Updt Int	software update in progress	camera software and firmware is updated
Async	camera speed is not the chosen speed	actual camera speed is not the intended speed
end	film end detected	no more raw stock
bat	camera supply voltage too low, change battery	battery voltage is too low

Problem	Cause	Remedy
Scratches on the emulsion side of the negative		
In the image area, over several frames	Dirty or damaged cross bars on the film gate	Clean or, if defective, replace the film gate
In the image area, short and periodically recurring (above and below)	Upper or lower film loop too long, film touches inside of magazine throat	Check the loop length of the magazine
Outside the image area	Dirty or damaged longitudinal bars on the film gate or film running surfaces in the magazine throat	Carefully clean film gate and magazine throat or, if defective, replace
Scratches on the glossy side of the negative		
In the image area	Dirty or damaged film track or pressure plate	Clean film track and pressure plate or, if defective, replace
Outside the image area	Dirty or damaged longitudinal bars on the film track or film running surfaces in the magazine throat	Carefully clean longitudinal bars and magazine throat or, if defective, replace
Scratching in general	Strong tendency of raw film stock to build up emulsion, dust on raw stock from perforation process, extreme temperatures, scratched raw stock	Notify the manufacturer of the film stock, use different film stock

Problem	Cause	Remedy
<p>Unsteady Image</p> <p>Vertical</p>	<p>Heavy emulsion build-up in the film gate area, damaged film perforation, very poor gliding ability of the raw film stock, film stock with positive perforation, dimensions of raw stock out of tolerance</p>	<p>Clean film gate area, use different film stock</p>
<p>Horizontal</p>	<p>Heavy emulsion build-up in the film gate area, film edge is not straight</p>	<p>Clean film gate area, use different film stock</p>
<p>Pressure exposures around perforation holes</p>	<p>Mechanical stress on the perforation holes</p>	<p>Pressure exposures do not affect the image steadiness</p>
<p>Image Problems</p> <p>Blurred image</p>	<p>Flange focal distance is set incorrectly, lens is set incorrectly, poor quality or defective lens, magazine pressure plate set incorrectly (image problem confined to one magazine)</p>	<p>When cleaning the film gate ensure that the surfaces are absolutely clean, check the lens and the flange focal distance Take magazine to ARRI Service Centre</p>

Problem	Cause	Remedy
Problems at extremely low temperatures		
Damage to the film	Greatly reduced tensile strength and increased brittleness of raw stock In temperatures under -15°C (5°F) especially, a change in the film's friction properties occurs.	The camera, battery and particularly the film stock must be protected from extreme cold. When a cold camera is brought into a warmer and humid room, condensation builds up This can be largely prevented by placing the cold equipment into a sealed plastic bag before moving it into the warmer environment. Remove it from the bag once the temperature has equalised.
The camera does not reach the selected frame rate	Capacity or voltage of the battery is insufficient Magazine tension is too high	Check the battery charge following the directions in the instruction manual. Check that the magazine turns easily.
Problems in extremely high temperatures		
Increased emulsion build-up	The mechanical properties of the film change considerably at temperatures of over 30°C (86°F). The film becomes soft and easily deformed. The friction coefficient changes and the film builds up more emulsion.	Protect the camera and the film stock from extreme heat, e. g. by shading or white covering etc.



Declaration of Conformity

This declaration is valid for following product:

Equipment: Camera

Type: ARRIFLEX 416

Hereby the equipment is confirmed to comply with the requirements set out in the Council Directive on the Approximation of the Laws of the Member States relating to Electromagnetic Compatibility (89/336/EEC) and the Council Directive relating to Low Voltage 73/23/EEC.

The following company is responsible for this declaration:

ARNOLD & RICHTER
CINE TECHNIK GmbH & Co. Betriebs KG
 Türkenstraße 89
 80799 München
 Germany

The measurements were carried out in accredited laboratories.

For the evaluation of above mentioned Council Directives for Electromagnetic Compatibility and for Low Voltage following standards were consulted:

DIN EN 55103-1: 1997-06
 DIN EN 55103-2: 1997-06

DIN EN 61000-3-2: 2001-12
 DIN EN 61000-3-3: 2002-05

DIN EN 60065: 2001-12

Munich / 30/11/2006
 Date / Place

Signature of responsible Person



Declaration of Conformity

This declaration is valid for following product:

Equipment: Camera

Type: ARRIFLEX 416 PLUS

Hereby the equipment is confirmed to comply with the requirements set out in the Council Directive on the Approximation of the Laws of the Member States relating to Electromagnetic Compatibility (89/336/EEC) and the Council Directive relating to Low Voltage 73/23/EEC.

The following company is responsible for this declaration:

ARNOLD & RICHTER
CINE TECHNIK GmbH & Co. Betriebs KG
 Türkenstraße 89
 80799 München
 Germany

The measurements were carried out in accredited laboratories.

For the evaluation of above mentioned Council Directives for Electromagnetic Compatibility and for Low Voltage following standards were consulted:

DIN EN 55103-1: 1997-06
 DIN EN 55103-2: 1997-06

DIN EN 61000-3-2: 2001-12
 DIN EN 61000-3-3: 2002-05

DIN EN 60065: 2001-12

Munich / 30/11/2006
 Date / Place

Signature of responsible Person

16. Technical Data

Film Format

Super 16 mm, conforming to DIN 15602 and ISO-5768-1998

Magazine

416 Shoulder Magazine 120/400 (SHM-3) forward only, up to 75 fps

Lens Mount

54mm PL-mount (positive locking)

Flange Focal Distance

52.0 -0.01mm

Mirror Shutter

Manually adjustable from 45° to 180°.

Movement

Silent precision movement,
single pull down claw,
single registration pin.
Pull down pitch adjustable

Speed Range

1-75 fps forwards only (quartz stabilized)
adjustable to 0.001 fps

Viewfinder

Adjustable in two axes with automatic image orientation compensation
and additional manual image compensation.

Fibre screens

Interchangeable for various filming formats,
same fibre screens as Arriflex SR16 3 Advanced.
Fibre screens from the SR16 1, 2 & 3 may also be used
but they incorporate a scale for a light meter which is not fitted to the 416.

Operating Temperature Range

-20°C to +50°C (-4°F to +122°F)

Power Supply

24 V DC

Acceptable voltage range: 20.6...35 V DC

Viewfinder Warning Indicators

Low power supply voltage (BAT)

Asynchronous running (ASY)

IVS

Weightapprox. 0.49 kg

Power Consumption.....approx. 4.8W

InputsNone

Outputs: 2 BNC outputs for composite video or alternatively
Y - C (S-video) over 2 BNC connectors
& 2 Mini-Monitor outputs

Optic.....covers Super 16 format

Optic Alignment:.....X, Y, rotation and focus

Dimensions

Length with magazine & viewfinder, without lens:405mm (16")

Width with viewfinder on the left:
(w/o handgrip)220mm (8 5/8")
(with handgrip)282mm (11 1/8")
with viewfinder on the right:.....254mm (10")

Height with grip:.....230mm (9")
without grip:180mm (7 1/8")

Weight

ARRIFLEX 416 Plus camera body

with loaded magazine, viewfinder, eyepiece, IVS but no lens: 5.5 kg (12.1 lbs)

17. Order Numbers

ARRIFLEX 416 Camera Body & SV-2 viewfinder	K0.60038.0
ARRIFLEX 416 Plus Camera Body & SV-2 viewfinder.....	K0.60037.0
ARRIFLEX 416 Camera Body only.....	K1.66000.0
ARRIFLEX 416 Plus Camera Body only	K1.66001.0
ARRIFLEX 416 Universal Viewfinder set (SV-2).....	K2.55025.0

Installation of the Camera

ARRIHEAD 2.....	K2.43670.0
ARRIHEAD 2 with Encoders.....	K2.52090.0

Wedge plate for Sled.....	K2.47092.0
---------------------------	------------

Lens support LS-7, ø 19mm	K2.42538.0
Lens support LS-8, ø 15mm	K2.49012.0

416 Shoulder Pad (SP-2)	K2.55030.0
-------------------------------	------------

Camera Handgrip, Right with On/Off Switch.....	K2.45886.0
--	------------

416 Riser.....	K2.35035.0
416 Split Bridge plate BP-10, ø 19mm.....	K0.60035.0
416 Split Bridge plate BP-11, ø 15mm.....	K0.60036.0

Support rods 240mm, ø 19mm	K2.43046.0
Support rods 240mm, ø 15mm	K2.21958.0
Support rods 340mm, ø 19mm	K2.47347.0
Support rods 340mm, ø 15mm	K2.47348.0

416 Standard Camera Handle.....	K2.55027.0
Handle Extension Block.....	K4.65107.0
416 Low Mode Support (LMS-1).....	K2.55029.0

Power Supply

416 On Board Battery (OBB-2)	K2.66000.0
416 On Board Battery Charger	K2.66004.0

Battery NC 24/7 R.....	K2.41950.0
Battery cable KC 20S	K2.41966.0
Charger NCL 24 R	K2.42010.0

Mains unit NG 12/24 R	K2.44481.A
Mains unit NG 12/26 (4-pin 12v).....	K2.47352.0
Mains unit NG 12/26 (5-pin 12v).....	K2.47351.0
Spiral battery cable KC 29S.....	K2.44693.0

Magazines

416 Shoulder Magazine 120/400 (SHM-3).....	K2.55026.0
Timecode exposure module.....	K2.55034.0

Optical Accessories

4" x 4" light-weight matte box LMB-3	K2.44471.0
6.6" x 6.6" light-weight matte box LMB-4a	K2.47633.0
4"x5,65" light-weight matte box LMB-5	K2.47239.0
4" x 4" production matte box MB-16	*K2.44472.0
4" x 4" production matte box MB-17B	*K2.47247.0
4" x 5.65" production matte box MB-18	*K2.47178.0
4" x 5.65" production matte box MB-19	*K2.47099.0
5.65" x 5.65" production matte box MB-20.....	*K0.60024.0
6.6" x 6.6" production matte box MB-14.....	*K0.59971.0
Heated eyecup HE-4.....	K2.47527.0
Cable KC-42 (for RS socket).....	K4.47473.0
Medium Eyepiece Extension	K2.55000.0
Long Eyepiece Extension	K2.55012.0

* These order numbers refer to matte boxes for ø 19mm support rods

Accessories

Accessory Power Box APB	K2.54177.0
External Display EXD-1	K2.55013.0
External synchronization unit ESU-1	K2.46006.0
Remote switch RS-4	K2.46942.0
Remote control unit RCU-1	K2.47197.0
Work light WL-2	K2.43197.0

Videassist

416 Integrated Videassist PAL.....	K2.47663.0
416 Integrated Videassist NTSC	K2.47664.0

18. ARRI Service

Germany Arnold & Richter
Cine Technik
Türkenstraße 89
D-80799 München
phone: +49 (089) 3809-0
fax: +49 (089) 3809-1244
E-mail: webmaster@arri.de

USA ARRI Inc.
(East Coast)
617, Route 303
Blauvelt, New York 10913
phone: (914) 353 14 00
fax: (914) 425 12 50
E-mail: arriflex@arri.com

(West Coast)
600 North Victory Blvd.
Burbank, California 91502
phone: (818) 841 70 70
fax: (818) 848 40 28
E-mail: arriflex@arri.com

GB ARRI (GB) Ltd.
2 Highbridge
Oxford Road
Uxbridge
Middlesex, UB8 1LX
phone: (0) 1895 457 000
fax: (0) 1895 457 001
E-mail: sales@arri-gb.com

Italy ARRI ITALIA S.r.l.
Viale Edison 318
20099 Sesto S. Giovanni (Milano)
phone: (02) 26 22 71 75
fax: (02) 242 16 92
E-mail: info@arri.it

Via Placanica, 97
00040 Morena (Roma)
phone: (06) 79 89 02 1
fax: (06) 79 89 02 206

Canada ARRI Canada Ltd.
415 Horner Avenue, Unit 11
Etobicoke, Ontario
Canada M8W 4W3
phone: (416) 255 33 35
fax: (416) 255 33 99
E-mail: service@arri-can.com

19. Index

- 24 V accessories 33
 - 416 riser 23, 26
 - 50 Hz 45
 - 60 Hz 45
- A**
- accessories 203
 - 24 V 33
 - accessory carrier 16, 19
 - accessory mounting points 203
 - accessory power supply 33
 - accessory rosette 26
 - Ambient Clockit 174
 - appendix 217
 - ARRIFLEX 416 Plus 185
 - ARRIGLOW 58
 - color 70, 71
 - ARRIHEAD 15
 - ARRIMACRO lenses 9
 - ASY 53, 59
 - AUTOADJUST 91, 114
 - AWB 88, 113
- B**
- BACKGROUND 153
 - ballast 45
 - bars, color 119
 - BAT 29, 53, 59
 - battery 28, 29, 30
 - cable 30
 - low level warning 66
 - warning level setting 58
 - bayonet mount 49
 - beamsplitter 50
 - beeper
 - beep on start 69
 - beep on stop 69
 - switching on / off 69
 - black and white output 82
 - BLUE 90, 114
 - BNC sockets 78
 - BOXED 153
 - BP-10 16
 - BP-11 16
 - bracket 24
 - button illumination
 - brightness 68

- C**
- cable warning..... 103
 - camera
 - running 55
 - stopping 55
 - camera body 43
 - camera operation..... 55
 - camera remote control..... 196
 - camera switch..... 55
 - CAS 65
 - charger 28, 29
 - check/hide menu 85
 - check menu 85
 - CID light..... 45
 - cleaning 211
 - cleaning the field lens 213
 - cleaning the film gate 212
 - CLM-1 188
 - CLM-2..... 188, 190
 - color bars..... 119
 - color bar generator 73
 - COMP..... 133
 - composite video outputs..... 79
 - CP..... 65
- D**
- DIMMER..... 70, 71
 - dioptré
 - adjusting 51
 - discharge lamps..... 45
 - display
 - display modes..... 58
 - display symbols..... 59
 - first display line..... 58
 - Mode 1 58
 - Mode 2 58
 - Mode 3 58
 - Mode 4 58
 - Mode 5 58
 - second display line..... 58
- E**
- EDIT TEXT 145
 - end 59
 - ESU-1 58, 175, 196, 206
 - exposed film
 - removing 40
 - external synchronization unit..... 206
 - eyecup HE-4 & HE-5 204
 - eyepiece..... 50

- F**
- feed side 35
 - fibre screen..... 213
 - exchanging..... 46
 - field lens cleaning 213
 - film core 36
 - film core slit 38
 - film counter..... 58, 142
 - configuration 58, 60
 - measurement units..... 61
 - modes 60
 - resetting 61
 - total exposed film 61
 - values..... 60
 - film gate cleaning..... 212
 - film sensitivity..... 182
 - film track cleaning rod..... 43
 - flicker free 45
 - on / off 97, 121
 - fluid heads..... 15
 - footage counter roller 36, 37
 - format marking
 - activate 129
 - changing 99
 - format marking menu 128
 - FORMAT OFF 129
 - forward guide roller 37
 - fps 59
 - frame counter 153
 - film 154
 - video..... 154
 - frame rate 62, 67
 - standard..... 62
 - frequency 45
 - fuses 217
- G**
- gain control 94
 - manual..... 117, 118
 - general description..... 13
 - GENLOCK..... 124
 - grip system 22
 - guide roller 36
- H**
- handle extension block 23
 - HE-4 204
 - HE-5 204
 - heated eyecup HE-4 & HE-5 204
 - HEB-1 23
 - hide menu 86
 - HMI light 45

- I**
- image
 - inverting 53
 - image orientation compensation 52
 - manually 52
 - reactivating 52
 - inching 57
 - IND 88
 - indoor 89
 - inserter
 - inserter facilities 105
 - inserting data in video 81
 - load/store menu 108
 - main menu 107
 - installation 15
 - interpolation 122
 - inverse 126
 - inverting the image 53
 - iris 86
 - IVS 73
 - cabling 78
 - default values 110
 - installation 76
 - transport cover 76
- K**
- KC-20-S 29, 30
 - KC-29-S 29, 30
 - keypad
 - brightness 58
- L**
- lay-on roller arm 38
 - LDB 186
 - LDD 201
 - LDD-FP 195
 - LDS 136
 - LDS line 139
 - LED 53
 - LED indication 29
 - left rod bracket 20
 - legal disclaimer 7, 10
 - Lens Data Archive 201
 - lens data display 201
 - lens data line 136
 - lenses 49
 - attaching 49
 - lens motors 188
 - lens mount receptacle 49
 - lens support 21
 - lightweight support 23, 26

lightweight support rods	26
line interpolation	122
LMS-2	24
load/store menu	108
LOAD SET	109
load settings	109
LOCK	57, 59
locking grip	35
LooP	47
loop check	47
loop length	37
loop length mark	37
loop protector	35, 41, 47
loop size	
checking	39
low mode bracket	24
low mode riser	24
low mode support handle	24
low mode support set	24
LS-10	21
LS-9	21
LWS-5	23, 26

M

magazine	35, 214
attaching	47
cover	35
feed side	35
loading	35
opening cover	41
release lever	47
removing	48
storage	41
take-up side	37
transport	41
main camera switch	55
main menu	107
mains unit	28, 30
maintenance	211
MAN	88, 113
manual gain	117, 118
control	112, 117
MGC	112, 117
mini-monitor output	84, 125
MINI MON DATA	125
mini monitor connectors	73
mirror shutter	43
angle measurement	61
mode 1	58, 62

mode 2	58, 63
mode 3	64, 65
mode 4	58, 67
mode 5	58, 68
mode 6	68, 69
mode 7	70, 71
motors.....	188
mounting points	203

N

NC 24/7 R.....	28, 29
NCL 24 R	28, 29
NG 12/24 R	28, 30
NG 12/26 R	28, 30
NORM	59, 62, 63

O

OBB-2.....	28, 65
charging.....	32
mounting	31
removing.....	31
on-board battery.....	28, 30
displaying information.....	65
release button	31
on-screen display	106
main menu	107
ON/OFF button.....	55

one push white.....	73, 91
operation.....	55
operational parameters	
displaying.....	57
setting	57
optics	49
OTD.....	88, 113
outdoor	89
OUTSIDE	131
overload.....	33

P

packing	15
parameters	
displaying.....	57
setting	57
PHASE	47, 56, 57, 64
phase shifting	64
PL-mount	49
plate	23
POSITION	129
post.....	22
power supply	28
accessory	33
displaying voltage	64
frequency	45
product identification.....	9

PS/CCU 59, 63
PS mode 63
pull-down menu 160

R

radio channel 187
radio system 186
RCU-1 196, 200, 207
rear guide roller 37
RED 90, 114
REMOTE 196
 connector 33
remote control 196
 remote control unit 207
remote heads 15
riser 23, 24, 26
rod bracket 20
rosette 26
RS-4 205
RS sockets 33
RUN 55
running camera 55
RUN switch RS-4 205

S

safety catch 35
safety instructions 7
SCH-2 22
SEL 57, 62, 63
sensitivity setting 182
sensitivity switch 38
SET 57, 62, 63
settings to default 110
sharpness value 122
shoulder operation 27
shoulder pad 19
shutter 43
shutter angle 43
 locking positions 43
 measurement 44
 setting 43
shutter tool 43
sled 16
SMPTE RP136 173
SP-2 19
split bridge plates 16
standard camera handle 22
status line 140
Steadicam 26
Steadicam plate 23

- stopping camera 55
 - STORD 133
 - STORE SET 108
 - Super 16 49
 - support handle..... 24
 - support rods 26
 - S VHS 80
 - system line 138
- T**
- tape hook 22
 - TC..... 59
 - TC-indication on the display 178
 - TC-Input 173
 - TC buffer 184
 - TC generator..... 173
 - TC output..... 175
 - TC recording
 - turning on/off..... 176
 - TCS value 182
 - TC time..... 151
 - TC Ubit..... 157
 - TC warnings 179
 - throat assembly cleaning 214
 - timecode 173
 - user bits..... 68
 - timecode and ESU-1 175
 - timecode exposure module..... 226
 - cleaning 216
 - timecode menu..... 150
 - timecode recording
 - switching on off..... 67
 - turning on/off..... 176
 - timecode sensitivity switch 38
 - TIMECODE TIME 151
 - timecode time 67
 - transfer roller 36, 37
 - transport..... 15
 - tripods..... 15
- U**
- UB 59
 - UMC-3..... 186
 - unit of measurement 58
 - User Bits 177
 - user bits menu..... 156
 - user text line 145
 - user text menu..... 144

- V**
- VBS mode 79
 - VBS out 79
 - video..... 153
 - adjustment..... 120
 - aligning image..... 87
 - background for additional lines..... 142
 - clean..... 79
 - clearing images 134
 - compare..... 133
 - composite 123
 - data insertion..... 123
 - default values..... 110
 - fine positioning 126
 - focus 87
 - format markings..... 129
 - format markings, darkening outside..... 131
 - format markings, white level..... 131
 - gain control 94
 - GENLOCK..... 124
 - inverse 126
 - iris 86
 - LDS line..... 136
 - line interpolation 122
 - lines positioning 126
 - one push white..... 114
 - positioning additional info lines..... 141
 - sharpening 122
 - standard controls 85
 - status line 136
 - store..... 133
 - storing images 134
 - switching on / off..... 85
 - system line..... 136
 - text adjustment..... 120
 - user text background..... 148
 - user text clearing..... 147
 - user text menu..... 144
 - user text positioning..... 147
 - user text size..... 148
 - with data 79, 123, 125
 - without data..... 123, 125
 - X, Y, Z adjustment 87
 - Y/C 123
 - Y/C data insertion 123
 - VIDEO/TEXT ADJUST 81
 - video assist 73
 - cabling..... 78
 - installation..... 76
 - video image
 - storing..... 101
 - video signal..... 64
 - interlaced 64

viewfinder	
adjusting	51
viewfinder arm.....	51
extending	52
swivelling.....	51
viewfinder system	50
removing	53
viewfinder warnings	53
VIEW MODE	133
VITC.....	165
VITC line menu.....	165

W

warning signal	
setting the volume.....	69
warning signs	7
WB	88, 112
WB/GAIN/BARS.....	90
WBU-3.....	190, 192, 193, 195
WEB-3	195
WFU-3.....	190, 192, 193, 194, 195
WHA-1	199
WHA-2	194, 198
white balance	88, 90, 112, 113
automatic	89, 113
indoor	89, 113
manual.....	113

manual, blue.....	93, 116
manual, red.....	92, 115
one push white.....	91, 114
outdoor	89, 113
white level	125, 131
white line menu.....	168
Wireless Main Unit.....	186
wireless remote control	208
wireless remote system.....	188
WL-3	204
WMU-2.....	196
WMU-3.....	190, 192, 193, 195, 196, 197
work light	204
WRC-1.....	196, 197, 198, 199, 208
WRS	186
WZB-3.....	193, 194, 195

Y

Y/C DATA	83
Y/C output	80
Y/C signal.....	78

Z

ZMU-3	192, 193, 194, 195
-------------	--------------------

IVS Quick Reference

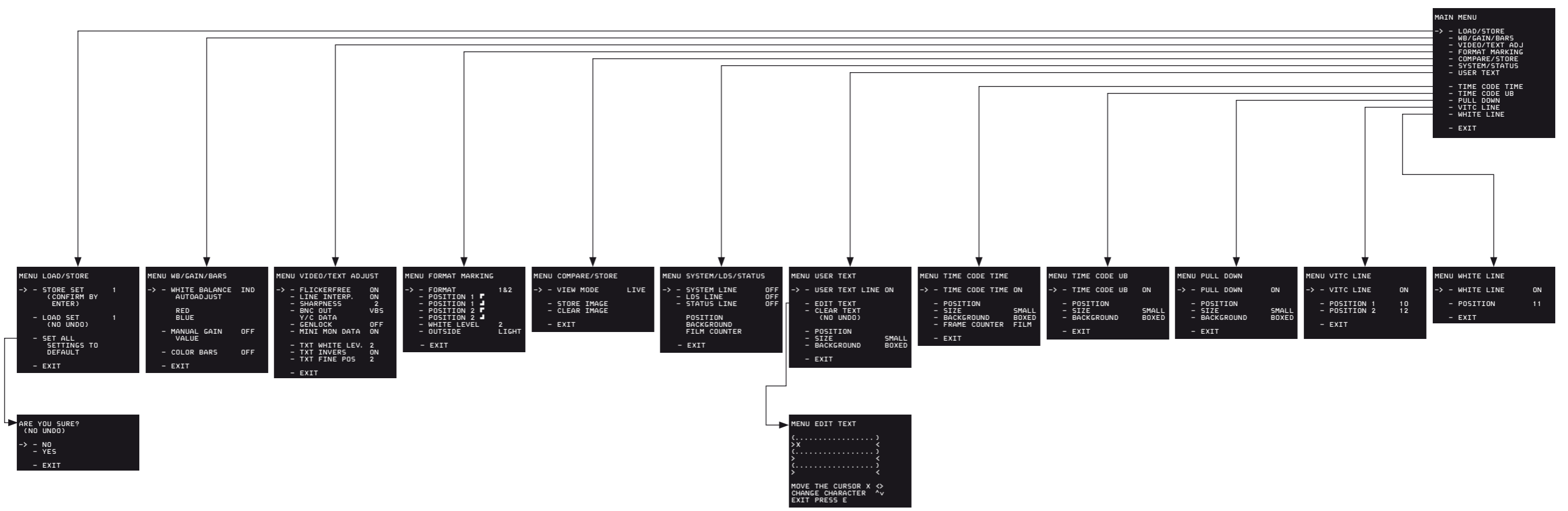
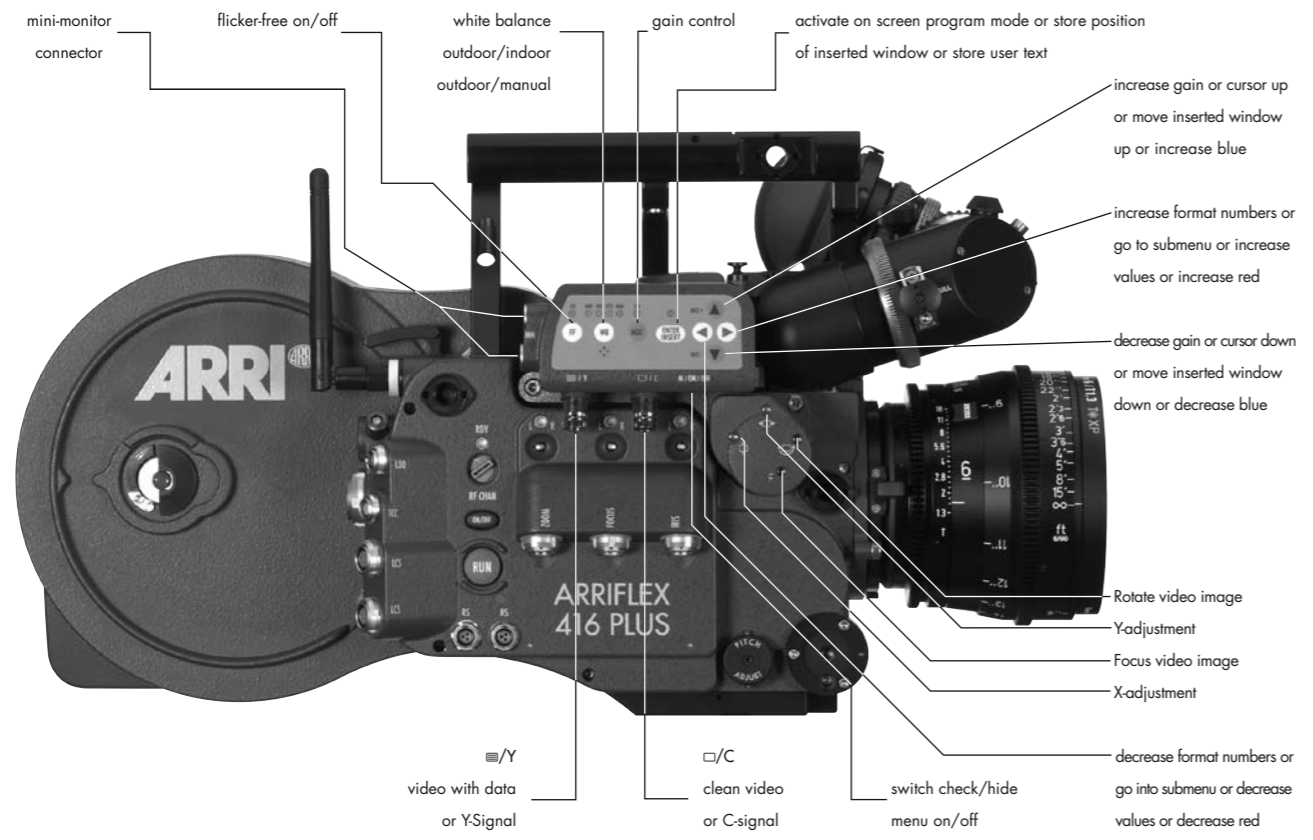

technical data are subject to change without notice

© ARRI 2006

Ident-No. K5.66324.0

available languages:

English



ARNOLD & RICHTER CINE TECHNIK

Türkenstr. 89 • D-80799 München

Phone +49 – 089 – 38 09 – 0 • Fax +49 – 089 – 38 09 – 12 44

www.arri.com