

C3119-27



# Canon SCOOPIC 16

INSTRUCTIONS

English Edition

## Technical Data

**Film:** Uses 16mm single or double perforated film on standard 100-foot (30.5-meter) spool.

**Lens:** Canon zoom lens C-16E F1.6 with zooming range of 13–76mm. 13-component, 18-element construction. Zoom ratio, 1:5.85. Zooming by rotation of lens barrel. Shooting distance, 1.5m (5ft.) to infinity. Inner diameter, 72mm. Outer diameter, 75mm.

**Viewfinder:** Single-lens reflex type with prism screen rangefinder and eyepiece adjustment ring. Contains f/stops scale, over/under exposure warning marks and manual aperture control mark. Eyecup is revolvable.

**Electric Eye Mechanism:** Automatic aperture mechanism fully coupled to highly sensitive built-in CdS cell.

**Light Measuring Range:** Film speed ASA 10–320 (DIN 11–26). Coupled to entire range of f/1.6–f/22 and 16–48 fps.

### Film Speed Indexes:

ASA	10	(12)	(16)	20	(25)	(32)	40	(50)	(64)
	80	(100)	(125)	160	(200)	(250)	320		
DIN	11	(12)	(13)	14	(15)	(16)	17	(18)	(19)
	20	(21)	(22)	23	(24)	(25)	26		

**Filming Speeds per Second:** 16 fps (1/43 sec.), 24 fps (1/64 sec.), 32 fps (1/86 sec.), 48 fps (1/128 sec.). Shutter opening angle, 135 degrees.

**Manually Operated Aperture:** Ordinary photography possible at any f/stop.

**Power System:** Electric motor system. Built-in micromotor is powered by a 12v nickel cadmium battery.

**Film Loading:** Semiautomatic film loading system. Just insert the tip of the film into the film feeding guide.

**Footage Counter:** Counts up to 100 feet. Needle automatically returns to "S" mark when side cover is opened.

**Power Source:** 12v nickel cadmium battery. Rechargeable. 12v x 2 parallel circuit for outside power source.

**Accessories:** Lens hood, battery charger, external battery box, close-up lenses, compensating filter for the CdS window and various types of filters available.

**Size:** 280 x 147 x 222mm (11" x 5-3/4" x 8-3/4")

**Weight:** 3.1 kg (6 lb. 13-3/8 oz.)

Subject to alterations.

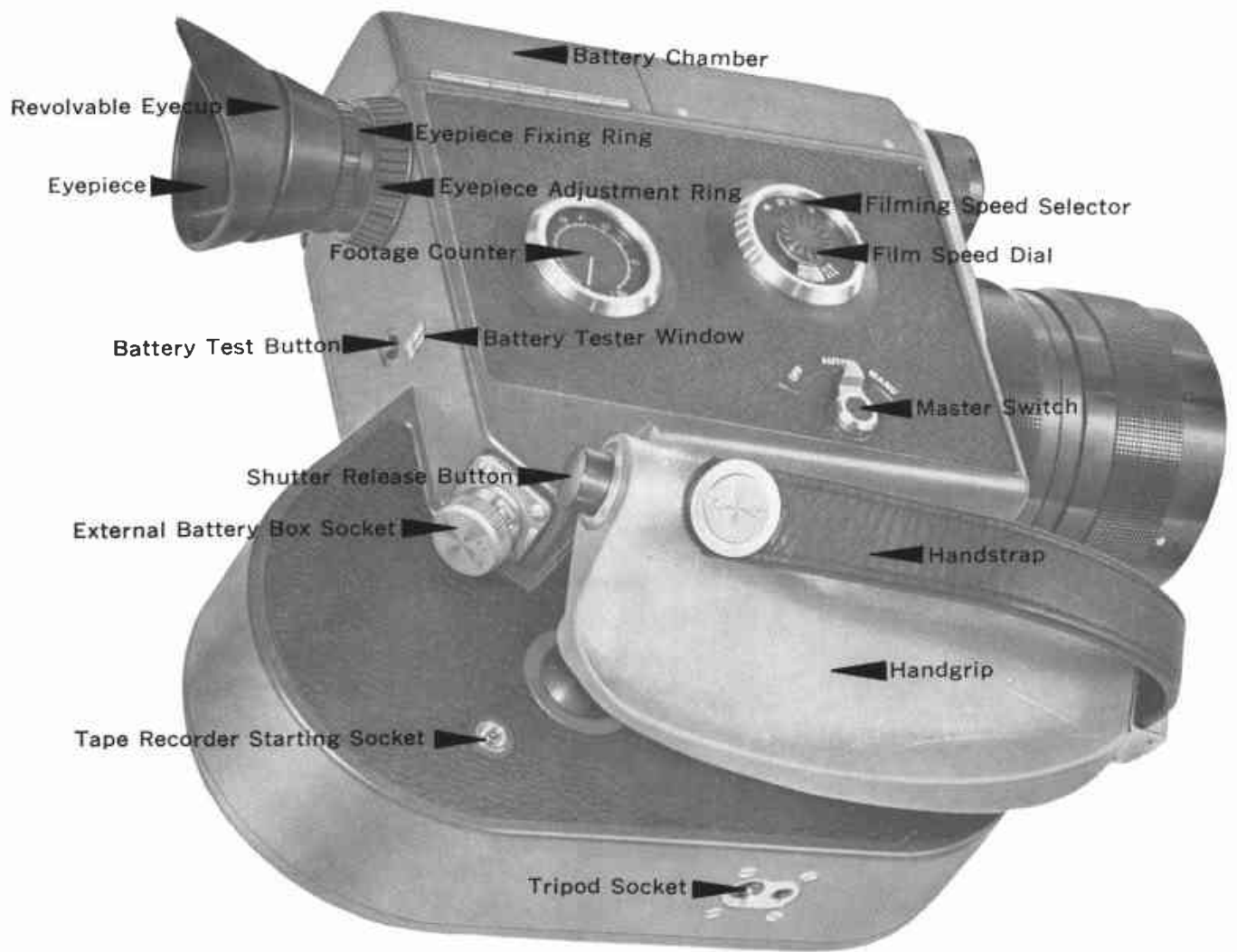



We are highly gratified that you have selected the Canon Scoopic 16—a wise choice that promises you many delightful years of photographic experiences.

Canon is recognized the world over as the foremost pioneer in the development of photographic equipment of the highest quality and performance. Whether it is for news reportage, laboratory or traveling, make the most of your opportunities!

#### **Before Using . . .**

It is important for you to thoroughly know and to get accustomed to handling the Canon Scoopic 16. Please read this instruction booklet carefully, and master the manipulations of the various parts completely before inserting the film into the camera. If you are thoroughly versed in the correct handling of this movie camera, you can get the maximum performance out of the Canon Scoopic 16 to your greatest satisfaction.

---

#### **Canon Scoopic 16 Set**

Main Body of Scoopic 16	1 unit
12 v Nickel Cadmium Battery	1 pc
Lens Cap	1 pc
Lens Hood	1 pc
Scoopic Battery Charger-S	1 unit
Carrying Case	1 pc
Spool	1 pc

## RUNNING LOCK

While depressing the shutter button all the way down, turn it clockwise and set "RL" at the index mark. You can now release your finger from the button and the camera will continue to run until the button is returned to its original position.

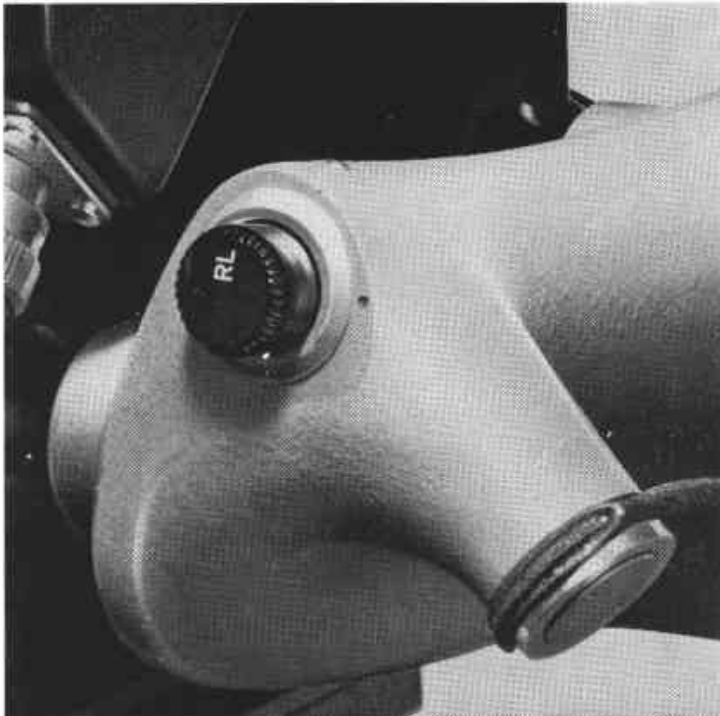

## Main Features of Canon Scoopic 16

**1 First 16mm Movie Camera to Incorporate Zoom Lens:** Canon Scoopic 16 is the world's first 16mm movie camera to incorporate a built-in zoom lens. The zoom lens on this revolutionary movie camera has a zoom ratio of 1 : 5.85, or a focal length of 13mm wide-angle to 76mm telephoto which covers the focal lengths used most often. The lens speed is a pre-eminent F 1.6.

**2 First 16mm Movie Camera to Incorporate Electric Eye with Manual Override:** Shooting with accurate exposure is always possible with the automatic aperture mechanism which is coupled to the built-in CdS cell. It couples to the entire range of this camera's f/stops and filming speeds. Switch-over from electric eye mechanism to manual operation is easily done by shifting the master switch.

**3 Bright Viewfinder with Prism Screen Viewfinder:** Bright, easy-to-see single-lens reflex viewfinder eliminates parallax displacement and the Scoopic incorporates a prism screen range-

finder to assure accurate focusing. All the necessary information, f/stops, over/under exposure warning marks and manual aperture control marks, are visible inside the viewfinder. The rubber-hooded eyecup, which effectively cuts out extraneous light, is movable from left to right or vice versa and is adjustable from -4 to +1 diopters.

**4 Powerful NiCd Battery Power Supply:** A 12 v nickel cadmium rechargeable battery is used as the power source for film drive and the electric eye circuit. This small and high performance battery can be used semipermanently. A fully charged battery will provide power for filming 800 feet at 24 fps. The battery can be completely recharged in 14 hours with the exclusive battery charger.

**5 Semiautomatic Film Loading Mechanism:** This is one of the mechanisms that has made Canon Scoopic 16 easier to handle and eliminates misloading. Insert the film leader into the insertion guide, press the shutter release button, and the film will automatically feed through the various guide elements.

## Procedures for Electric Eye Operation

1



Charge the battery.  
Page 10

2



Load the battery.  
Page 12



Check the power level  
of the battery.

3

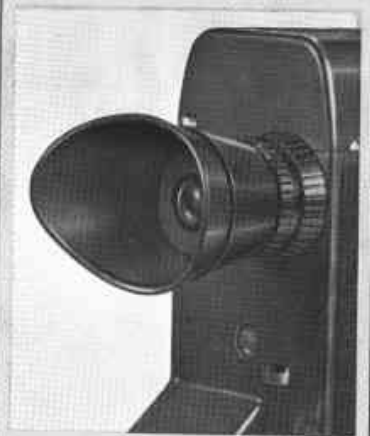

Adjust the eyepiece to  
your eyesight.  
Page 13

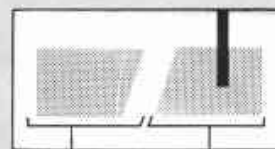

Replace the  
battery

Sufficient  
(Blue)

4

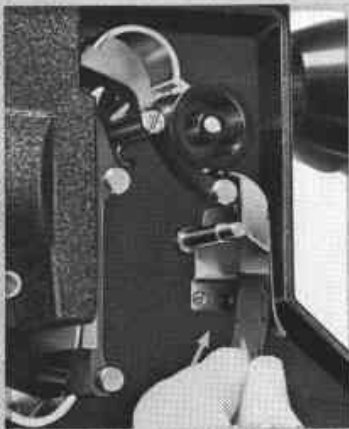

Load the film.  
Page 27

5



Set the film speed dial.  
Page 13

6

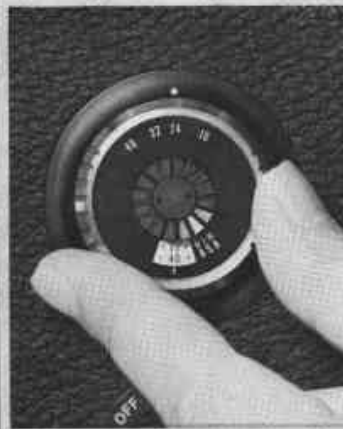

Set the filming speed  
at 24 fps.  
Page 14

7



Set the master switch  
at "AUTO".  
Page 16



8



Remove the lens cap.

9



Hold the camera and look into the viewfinder.  
Page 17

10



Focus at telephoto.  
Page 20

11



Decide the composition of the picture by turning the zoom lens.  
Page 18

12



Press the shutter release button lightly.  
Page 22

13



Check the position of the exposure meter needle.  
Page 21

14

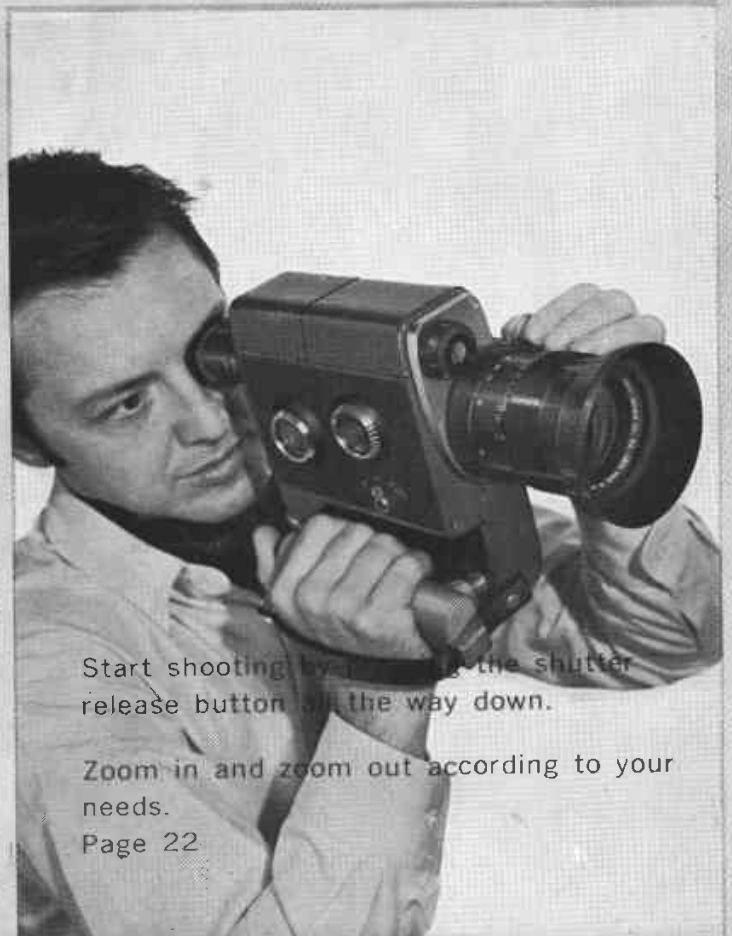

Start shooting by pressing the shutter release button all the way down.

Zoom in and zoom out according to your needs.

Page 22



## How to Charge the Battery

An exclusive type 12 v nickel cadmium rechargeable battery is used in the Scoopic 16 as the power source for film drive and electric eye. The camera functions only when this charged battery is properly loaded. A fully charged battery will provide power for driving eight reels of 100-foot (30.5-meter) length film at 24 frames per second.

▶ Since this battery is not charged when you purchase it, be sure to charge the battery before loading it into the camera.

### Canon Scoopic Battery Charger-S

The exclusive Battery Charger-S is used for charging the nickel cadmium battery. Each battery can be charged simultaneously either in a pair or singly.

**1** Set the voltage switch according to the voltage to be used. For example, in a locale where the household voltage is 220 v, set the voltage switch at 200–240 v.

▶ Be very careful not to make a mistake on the voltage setting.

**2** Insert the battery after matching the + and – markings on the battery with those on the charger.

**3** The pilot lamp lights up when the charger is connected to the power supply.

**4** Each exhausted battery can be fully charged approximately in 14 hours. The electronic circuit incorporated inside the charger automatically switches off when fully charged.

◆ Recharge the battery if it has not been used for over one month.

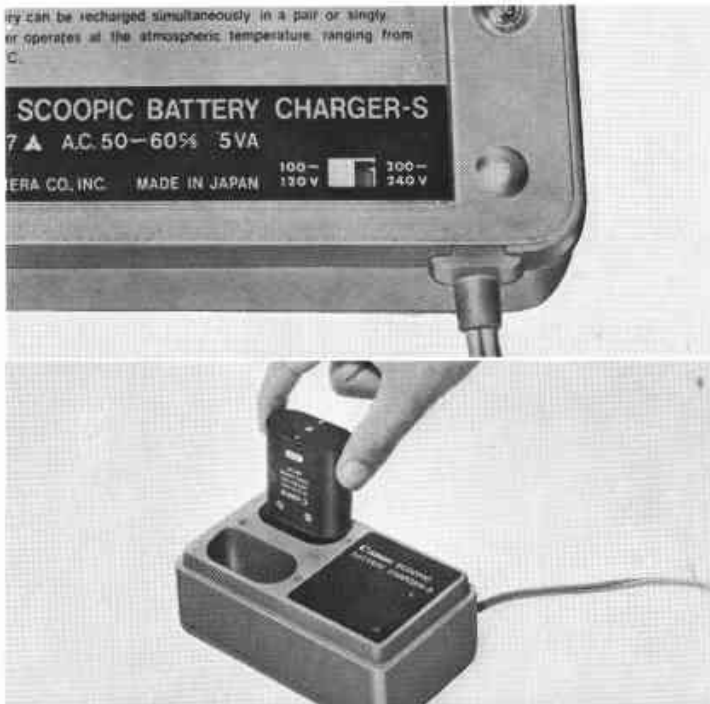

## How to Load the Battery

- 1 Press the battery chamber release button. This releases the lock and frees the cover.
  - 2 Open the cover and load the battery, matching the + and - markings on the battery with those in the battery compartment.
- ◆ Take the battery out of the camera when it is not to be used for a prolonged period of time.
  - ◆ It is best to always carry extra batteries for worry-free shooting.

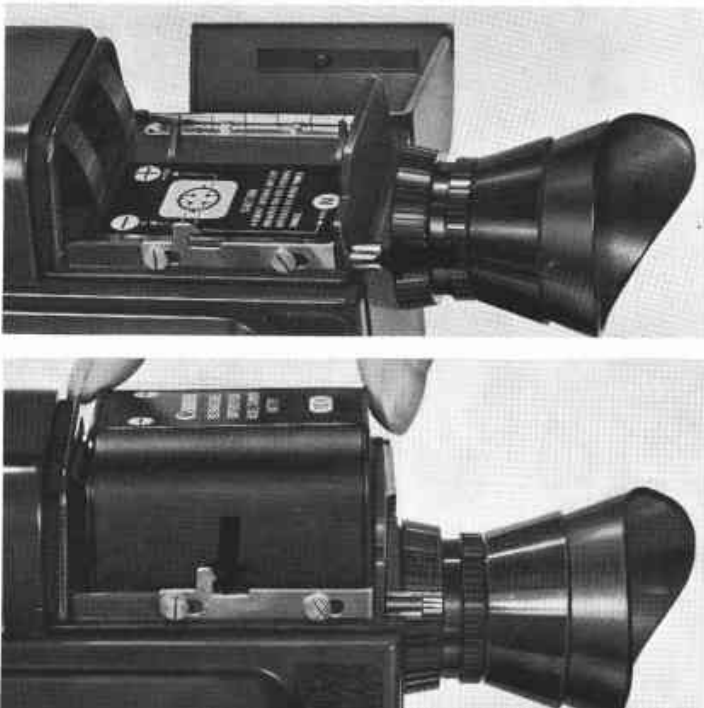

## Checking the Battery

Check the power level of the battery regularly. Press the battery test button and check the position of the needle in the battery tester window. If the needle reaches the blue zone, it means the battery has sufficient power level. Otherwise, replace the battery.

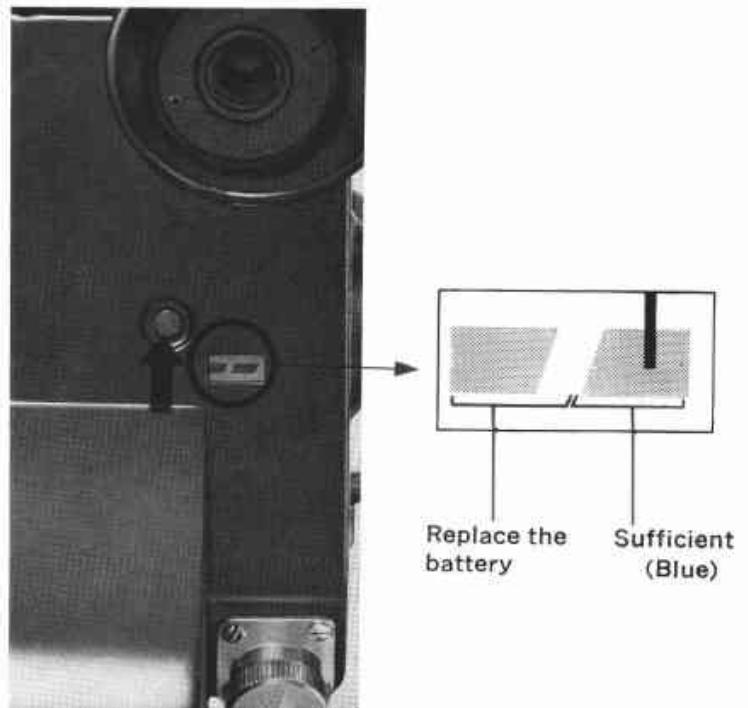

## How to Adjust Eyepiece to Eyesight

Remove the lens cap and aim the camera in the direction of a bright subject and look into the viewfinder. Turn the eyepiece adjustment ring and adjust so that the lines of the round prism screen rangefinder can be seen most distinctly. Then tighten the eyepiece fixing ring.

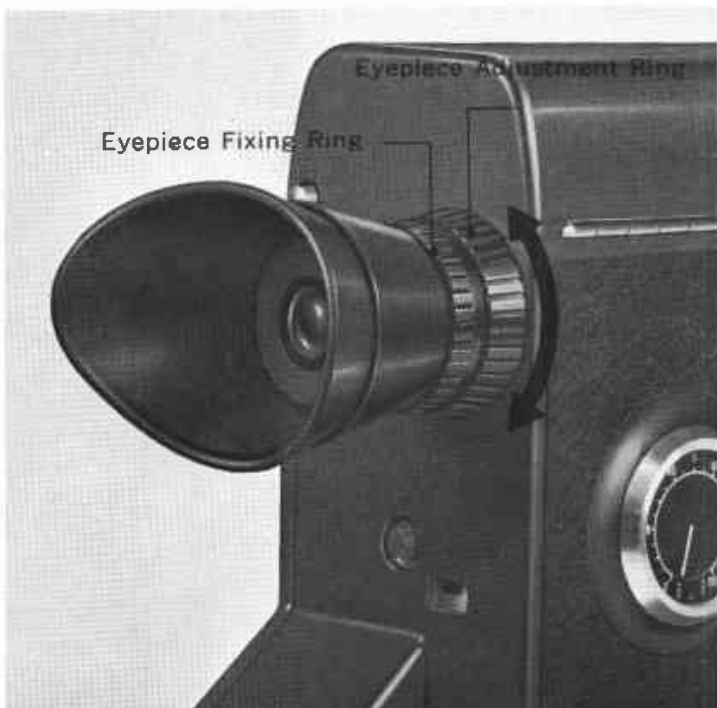

## How to Set the Film Speed

The electric eye of Scoopic 16 is completely coupled to the film speed, filming speed and automatic aperture mechanism. Be sure to set the film speed dial after loading film so as to obtain the correct exposure. Set the film speed dial to the click-position ASA/DIN index of the film to be used.

► The film speed dial is indicated in both ASA and DIN indexes.



## How to Set the Filming Speed Selector

The filming speed selector sets the number of frames to be fed per second. Turn the filming speed selector and set the desired filming speed graduation to the index. 24 frames per second is the standard filming speed for 16mm movie cameras.

➤ When shooting at 48 or 32 frames per second, the motor consumes a considerable amount of power and requires sufficient power level.

➤ Do not turn the filming speed selector while pressing the shutter release button.



➤ The shutter opening angle is 135 degrees. The relations between the number of frames per second and the exposure time are as follows:

Frames per Second	16	24	32	48
Exposure Time in Seconds	1/43	1/64	1/86	1/128

➤ The camera will function properly only at the graduations on the filming speed selector.

➤ Avoid operating the camera at high filming speeds when film is not loaded.



## Filming Speeds and Projection Effects

Film shot at filming speeds other than 24 frames per second will have varying effects when projected.

**1** When shooting at high filming speeds of 48 or 32 frames per second, the projected pictures will have a slow-motion effect. For example, when a film is shot at 48 frames per second and then projected at a standard 24 frames per second, the projecting time will be lengthened by two times, thereby slowing down the speed of motion by one-half. High filming speed is,

thus, very effective when slowing down fast moving subjects or when analyzing movements. Exposure time is also speeded up and is, therefore, effective for eliminating blurring during panning.

**2** When shooting at slow filming speed of 16 frames per second, the opposite effect of high filming speed is obtained. In other words, by dropping the filming speed the projected pictures will have a fast-motion effect. This method is used when stressing the movement of a subject,





when a realistic effect in the movement of a distant subject is desired, or for humorous effects. The slow filming speed is also used in order to widen the proper exposure range for overcoming under-exposure conditions, that is, when it is too dark for shooting at 24 frames per second even at maximum aperture opening. ♦ Avoid shooting subjects that show normal movements when using the slow filming speed for controlling exposure.



16

## Master Switch

When the master switch is set at "OFF", the electric eye circuit is disconnected and the shutter release button is locked. When the master switch is turned to "AUTO", the electric eye and power circuits are connected and shooting with automatic exposure control becomes possible. The electric eye circuit will function when the shutter release button is pushed in. When shooting with manual aperture control for special effects, set the switch at "MANU.". See page 23.



## How to Hold the Camera

Firmly grasp the handgrip with the right hand. The shutter release button is pressed with the right thumb. Focusing, zooming and steadying of the camera are performed with the left hand. The camera should be held steady, especially when shooting in telephoto or when zooming. The use of a tripod is recommended in these cases.

### Handstrap

Open the handstrap buckle and adjust the length of the handstrap according to your hand.



### Eyecup

The eyecup is of the revolving type and is revolvable from left to right or vice versa. Adjust it to fit your eye.

◆ Do not take your eye away from the eyecup during shooting. This is because, if strong light should enter the viewfinder through the eyepiece, the light will flow in reverse direction through the viewfinder optical system and cause fogging of the film.

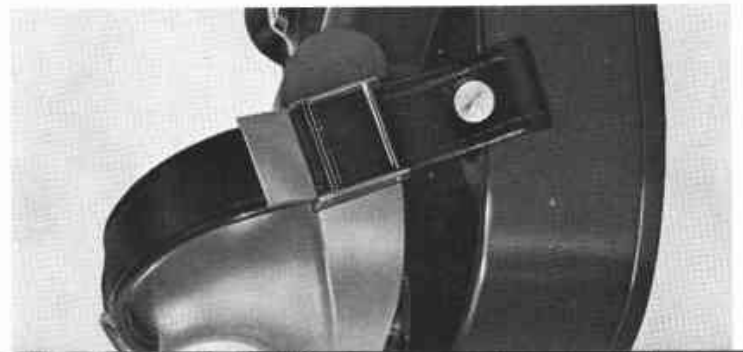
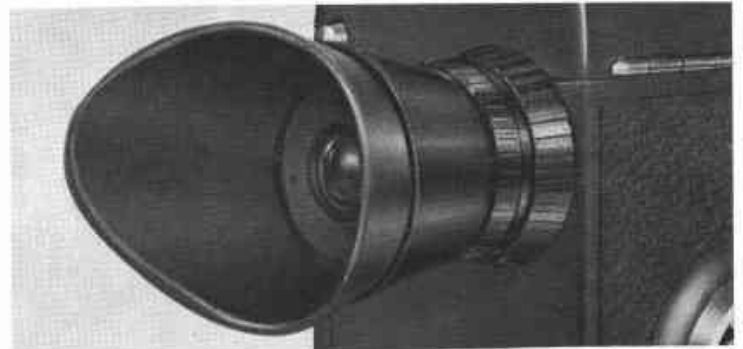

## Viewfinder

The viewfinder of Scoopic 16 is of the single-lens reflex type in which the field-of-view and the picture frame are identical. Therefore, the pictures can be composed within the maximum field-of-view. The following information is available inside the viewfinder: exposure meter needle, f/stop scale, over/under exposure warning marks and prism screen rangefinder.

## Zooming

When you wish to zoom or want to decide the size of the subject in the picture area, turn the zoom lens by using the zooming ring. The image seen through the viewfinder will change in magnification and the field-of-view will also change. The zoom lens eliminates the necessity of interchangeable lenses or the turret and very effective expressions become possible.



◆ The focal point does not change by turning the zooming ring.

◆ When you wish to keep the subject always in the center of the picture while zooming, fix the camera in a stationary position, set the subject in the center of the viewfinder at the maximum focal length of 76mm, and focus. Zooming can be performed from any desired focal length after that.

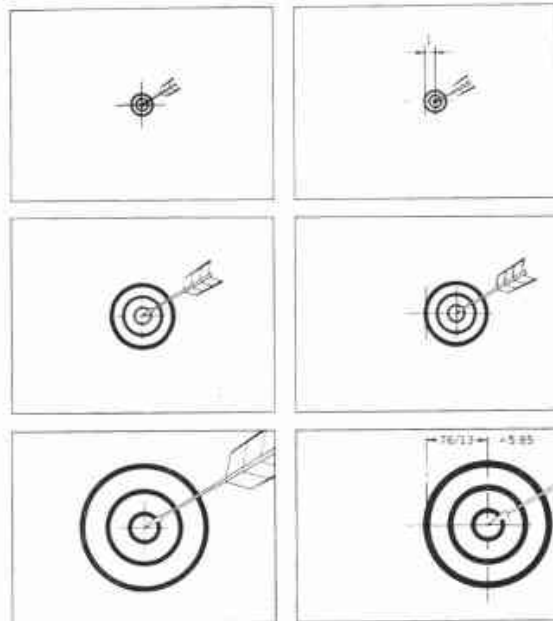

f = 13mm

f = 76mm

# Focusing

Look into the viewfinder and turn the focusing ring until the image in the central prism screen rangefinder can be seen most distinctly. The aligned image can be seen more accurately and easier the longer the focal length of the lens. Therefore, first focus at the maximum focal length of 76mm and then return the lens to the desired magnification. The lens can be zoomed to any focal length and still maintain a sharp-focused image.

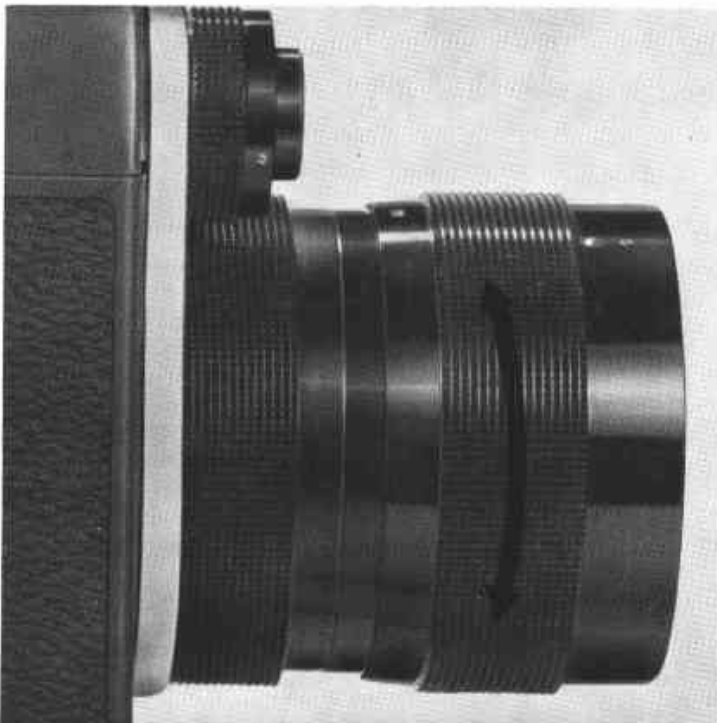

## Size of Subject at 1.5m (5 ft.):

Focal Length (mm)	13	25	38	50	76
Picture Area (cm)	72 x 100	36 x 50	24 x 33	18 x 25	12 x 16
Picture Area (in.)	2'4 <sup>3</sup> / <sub>8</sub> " x 3'3 <sup>3</sup> / <sub>8</sub> "	1'2 <sup>1</sup> / <sub>8</sub> " x 1'7 <sup>3</sup> / <sub>4</sub> "	9 <sup>1</sup> / <sub>2</sub> " x 1'1"	7 <sup>1</sup> / <sub>8</sub> " x 9 <sup>1</sup> / <sub>8</sub> "	4 <sup>3</sup> / <sub>4</sub> " x 6 <sup>1</sup> / <sub>4</sub> "

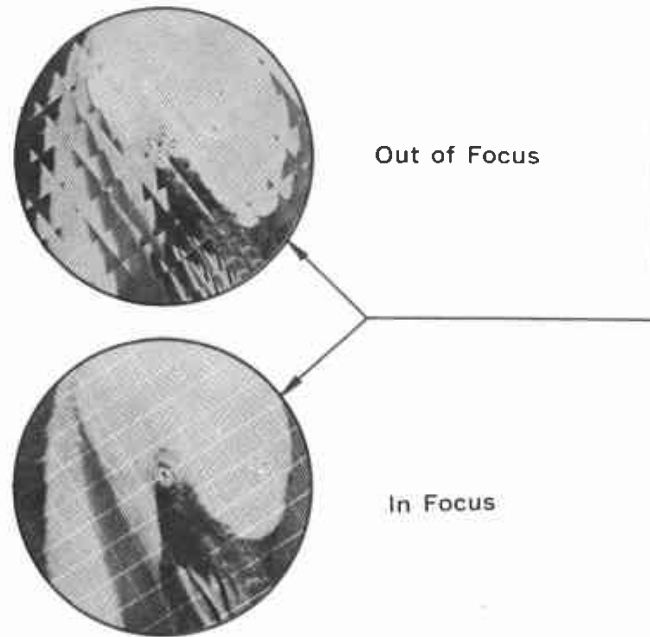

## Checking the Exposure Meter Needle

Aim the camera at the subject and check the position of the exposure meter needle inside the viewfinder. When you slightly press the shutter release button down approximately 1mm, the electric eye circuit operates and the exposure meter needle indicates the f/stop.

▶ The black dots in between indicate f/16, f/8, f/4 and f/2 respectively.

**1** If the exposure meter needle is within the range of the f/stop scale, you can press the shutter release button down all the way and the film

will advance.

**2** If the exposure meter needle points to the upper red mark, it indicates over-exposure. Shoot after attaching a neutral density filter to lower the light intensity.

**3** When the exposure meter needle points to the lower red mark, it indicates under-exposure. This condition must be corrected before shooting by adding auxiliary light.

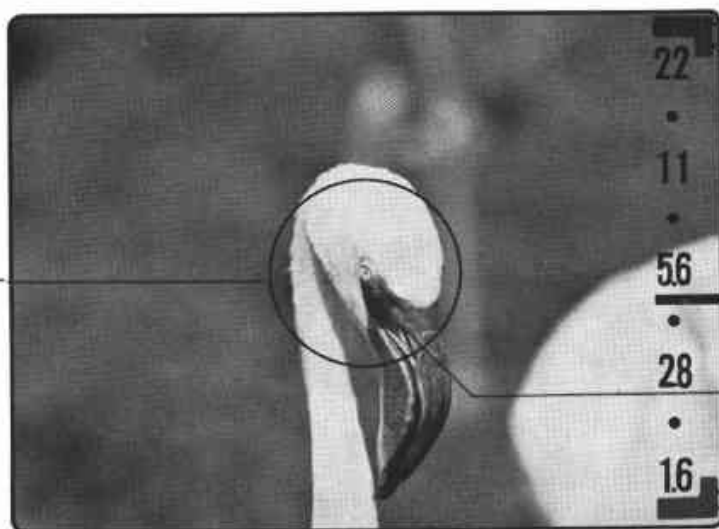

Over-Exposure Warning Mark

Use ND filter.

f/Stop Scale

Exposure Meter Needle

Prism Screen Rangefinder

Under-Exposure Warning Mark

Add auxiliary light.

## Shutter Release Button

Push the shutter release button all the way down for film drive.

◆ When the shutter release button is pressed only lightly, the operating sound of the electric eye can be heard but the film will not advance.

◆ Set the master switch at "OFF" when not shooting. The battery will not be consumed even if the switch is not set at "OFF", but it is a precaution to prevent film drive when the shutter release button is inadvertently pressed.



## Lens Hood

Always use a lens hood. Better quality pictures can be obtained because the lens hood cuts out harmful light. There are two types of hoods—use screw-in type filters in the case of the one type and Series IX filters for the another.

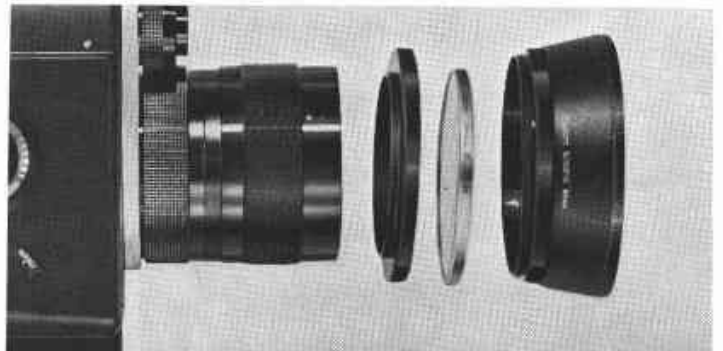
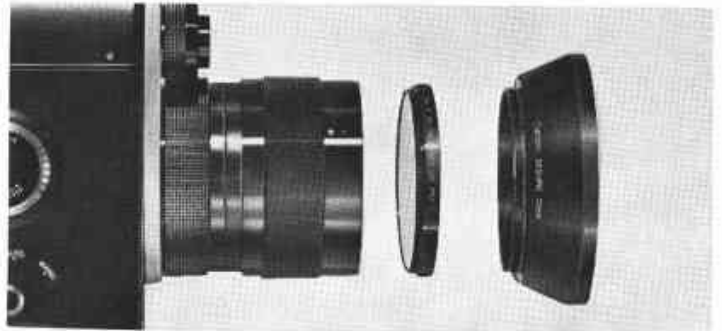

## Manual Control of Aperture

Observe the following procedures when shooting with manually controlled aperture.

**1** Set the master switch at "MANU.". The letter "M" will appear in the upper part of the viewfinder.

**2** Turn the aperture control ring and set the exposure meter needle inside the viewfinder to the desired f/stop.

◆ The aperture control ring moves only when the master switch is set at "MANU.".

**3** Zooming and focusing is performed in the same manner as in electric eye operation.

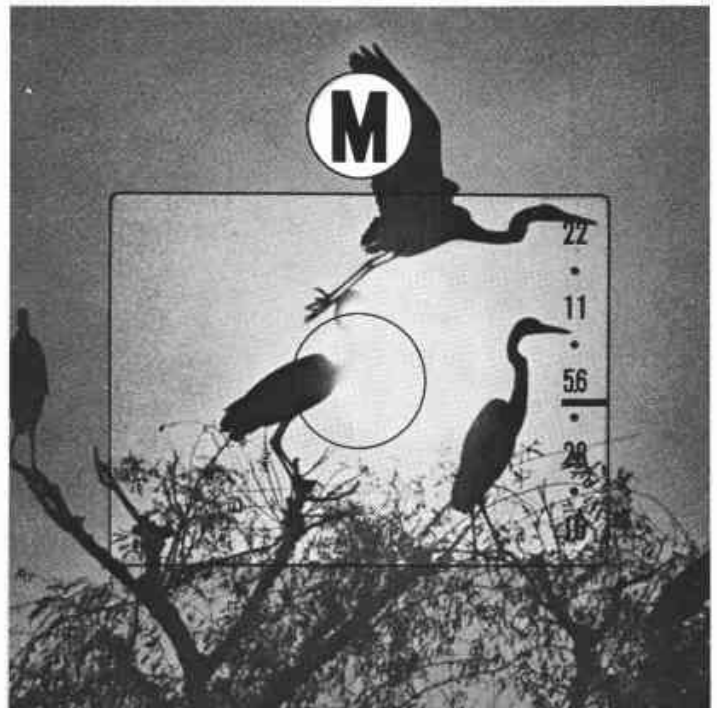



## Filters and Exposure Compensation

When using filters the exposure must be adjusted according to the exposure factor of the filter to be used.

### Adjustment by Changing the Film Speed Dial Setting

Divide the ASA index of the loaded film with the exposure factor of the filter to be used. The figure obtained is the ASA index of the film when the filter is used. Therefore, set the film speed dial to this ASA figure.

For example, when a Y3 (exposure factor 2) filter is used with an ASA 100 film, the compensation ASA number would be:  $100 \div 2 = 50$ . In other words, the film speed dial should be reset at ASA 50.

### Adjustment by Changing the f/Stop

Turn the master switch to "MANU.". Adjust the f/stop by turning the aperture control ring according to the exposure factor of the filter to be used. The f/stop graduations are indicated in multiple. Therefore, when using a filter with an exposure factor of 2, the f/stop is increased by 1 graduation. When the exposure factor is 4, it is increased by 2 graduations.

### Adjustment by Using Compensating Filter for CdS Meter

When using an ND 4 filter, a compensating ND 4 filter to be attached onto the CdS window is available. In this case, there is no need to change the film speed dial setting or the f/stop.

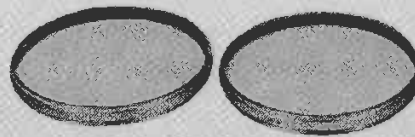

### Filters

A wide variety of Canon Filters 72mm (screw-in type) and Series IX are available. When using filters, exposure time must be increased according to the exposure factor of the filter to be used. A lens hood attachment screw is also available.

### Compensation Filter ND 4 for CdS Window

The compensation filter ND 4 for the CdS window is available.

### Canon Filters 72mm/Series No. 9

Type	Exposure Factor	Effectiveness of Filters
○● UV	1	Absorbs only ultra-violet rays. Especially effective at seaside, and high mountains. Recommended for use in color photography.
○ Y1 Y3	1.5 2	Increases contrast of black and white film. Enhances clouds, darkens the blue sky. Brightens red and yellow.
○ R1	6	Makes strong contrasts. May also be used with infrared film.
○● ND4 ND8	4 8	ND4 reduces light values by 1/4, ND8 by 1/8. No effect on the reproduction of colors.
● SKYLIGHT	1	Acts to harmonize the blue sky and shade.
● CCA4	1.5	For use with daylight type film under the cloud.
● CCA8	2	For use with universal type (color negative) film under the cloud or tungsten type film under the morning sun or sunset.
● CCA (12)	2	For use with tungsten type film under sunlight.
● CCB4	1.5	For use with daylight type film under the morning sun or sunset.
● CCB8	2	For use with daylight type film and clear flash bulb.
● CCB (12)	3	For use with daylight type film under tungsten light.

○ For black and white film. ● For color film.

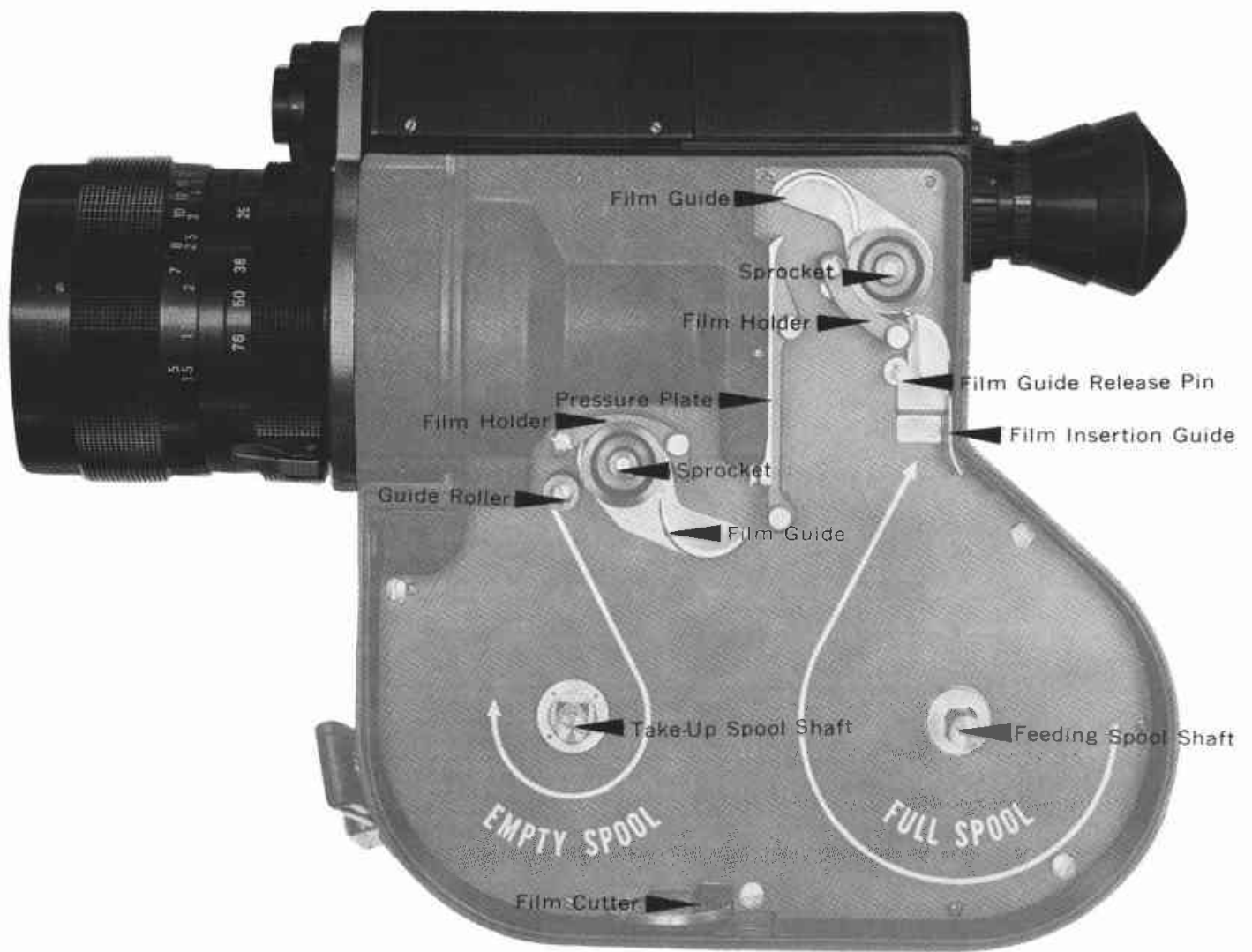

## How to Load Film

Any standard 16mm, single or double perforated, 100-foot (30.5-meter) long film spool can be used. Film is loaded by the semiautomatic loading system and can be easily performed once you know how. Make a habit of loading film correctly, since carelessness may cause racing or fogging of the film.

◆ As the film is wound naked around the reel, always load film in the shade. An extra length of leader is attached to the film for protection against the entry of light, but direct sunlight or

strong lighting may cause fogging of the film if it is loosely wound.

**1** Flip up the side cover latch, turn it in the direction of the arrow and remove the side cover.

**2** Place the film spool on the feeding spool shaft as indicated by the diagram inside the camera.

◆ Some spools can be placed on the shaft only when they are inserted in the correct direction.

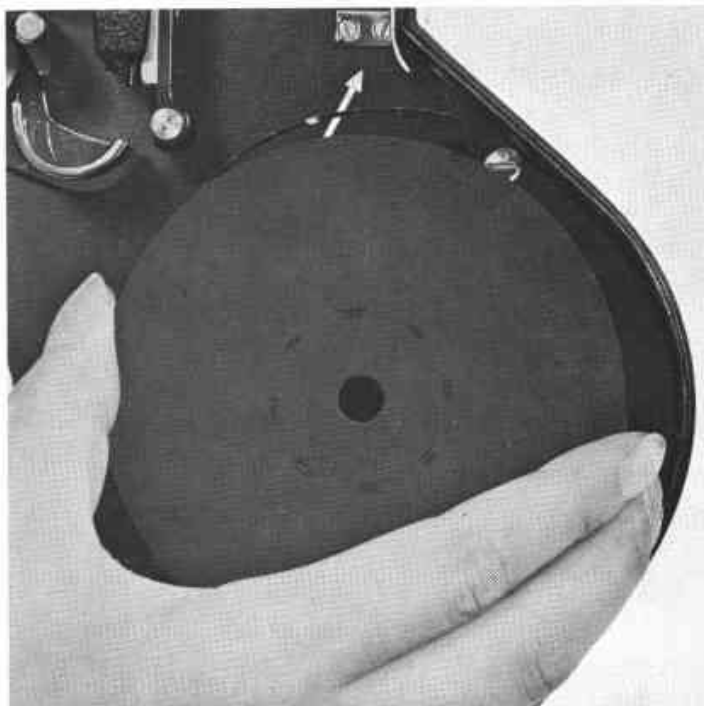

**3** Cut the tip of the film leader at a right angle, using the built-in film cutter. Cut the tip of the film leader in between the perforations by matching a perforation and a pin on the cutter.

**4** Set the filming speed selector at "16" or "24".

**5** Insert the tip of the film leader into the film insertion guide. Be careful to keep the film tightly wound on the reel.

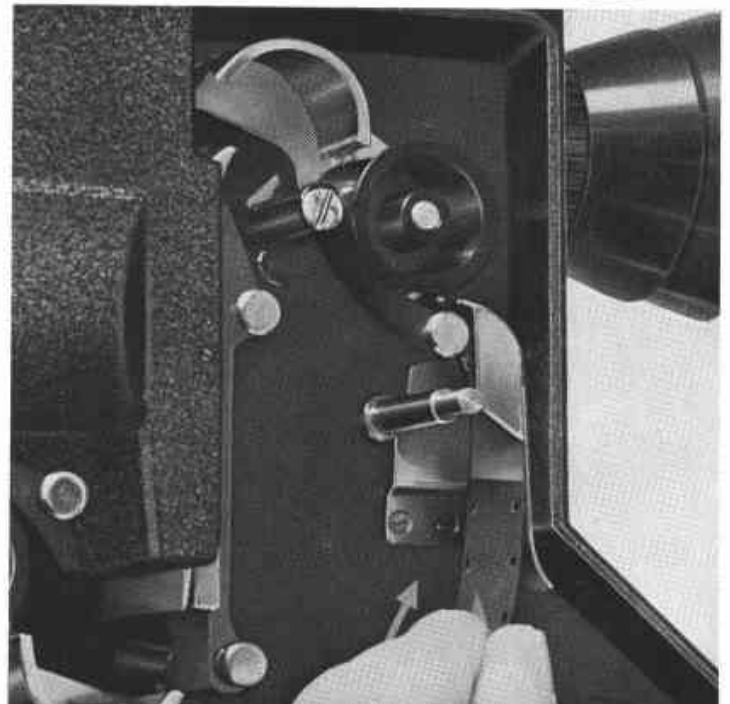
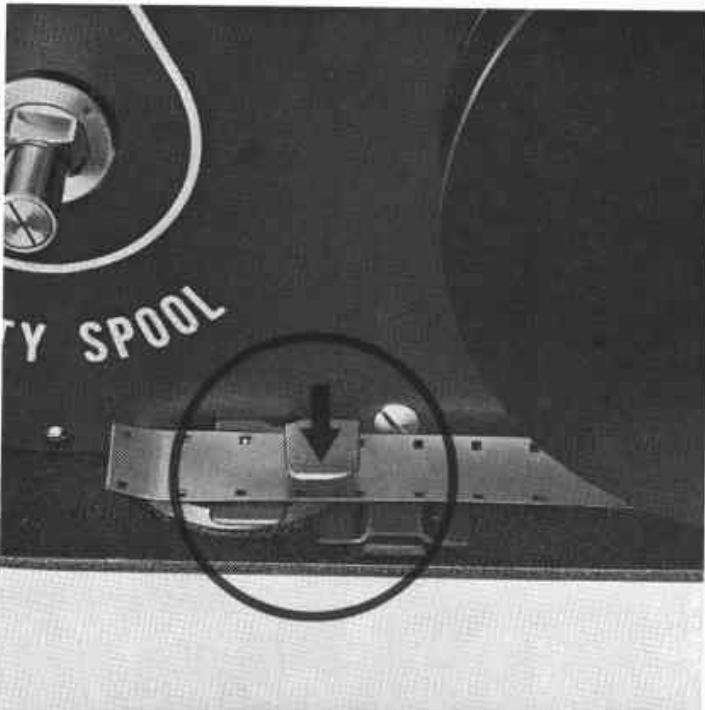

**6** Be sure that the film holder on the feeding spool shaft is at the proper position. Press the shutter release button while pushing the film leader into the film insertion guide.

The film will automatically proceed through the film guide and the aperture section and come out from the bottom sprocket. Stop pressing the shutter release button when 15 to 20cm of film leader has passed through the bottom sprocket.

**7** Have the take-up spool ready. Check and see that the top side of the spool is facing upwards.

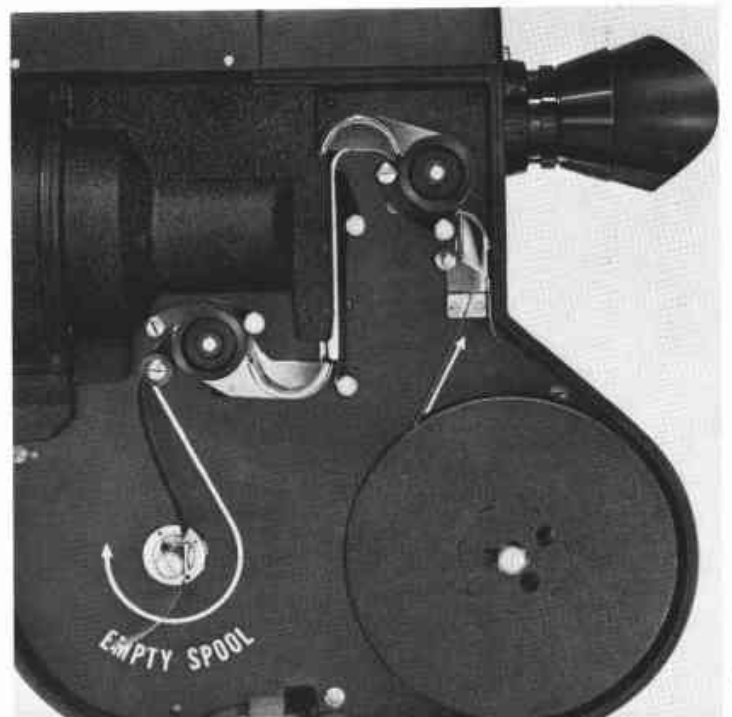
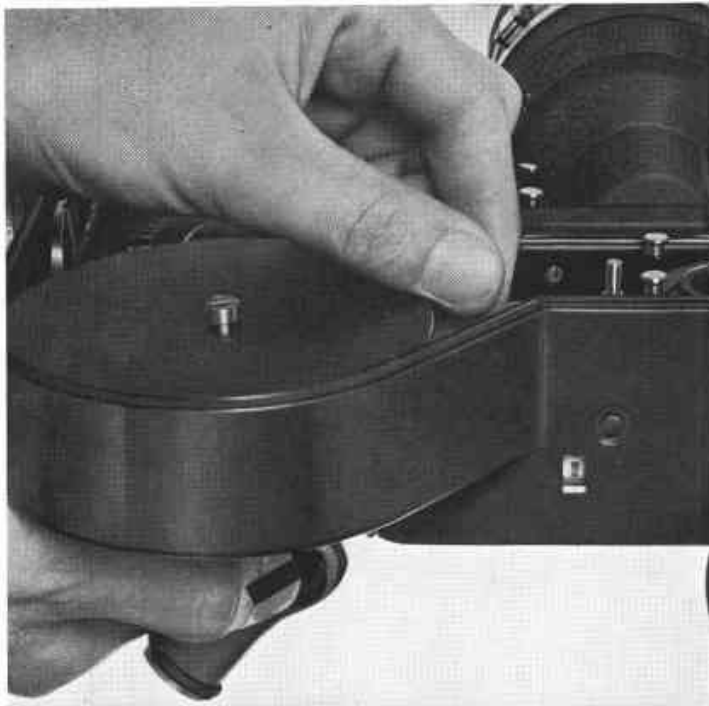

**8** Bend the tip of the film leader towards the emulsion side and insert into the take-up spool as indicated by the diagram inside the camera. Wind the film leader tightly 3 or 4 times around the spool.

**9** Place the take-up spool on the take-up spool shaft.

➤ Be sure to check that the pressure plate and the film holder are in the normal positions and the knobs are dropped in. (See the picture in the following page.)

**10** Press the shutter release button, while pressing the film guide release pin (the film guide is in open condition), and check to see that the top and bottom film loops are uniform. About one second, or 10 to 15cm, of film feed is sufficient.

**11** Put the side cover back on, turn the film side cover latch and flip it down.

➤ The film holder on the take-up sprocket must be at the correct position in order to close the side cover properly.

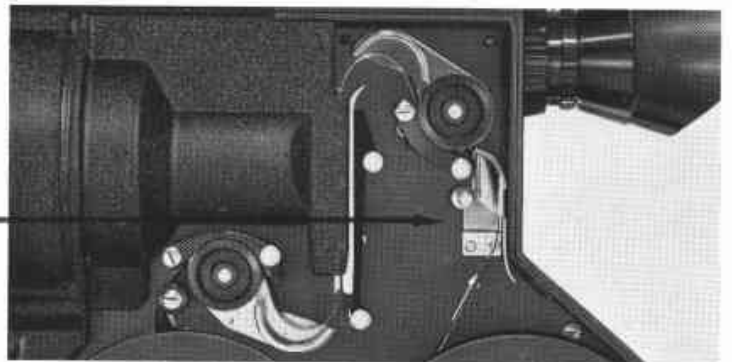
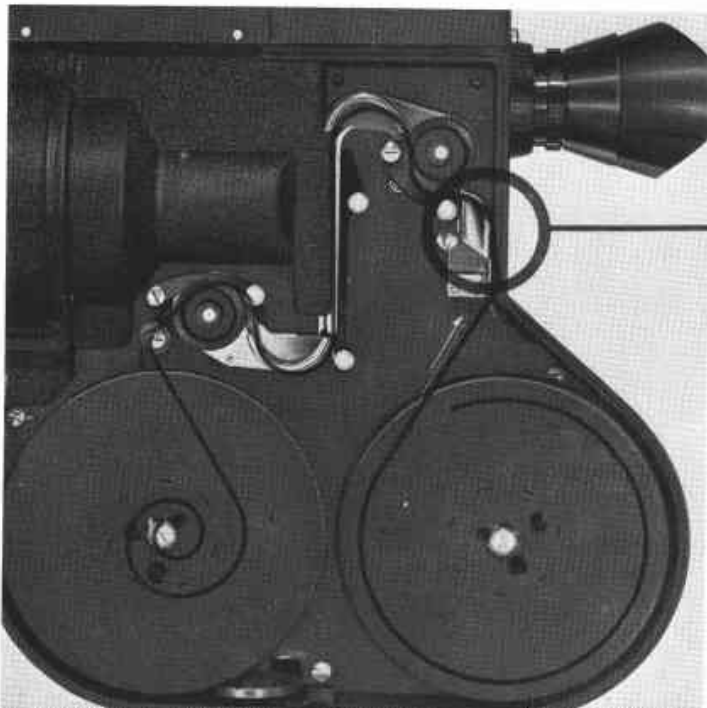

**12** Press the shutter release button and feed the film until the footage counter moves from "S" to "0". Start shooting from "0" position.

### Various Releases

As the various parts can be opened, they are convenient for correcting an improperly loaded film. Moreover, as the pressure plate can be removed by unscrewing the tightening screw, it is very convenient for removing the film or cleaning the aperture section.

**1** The film guide opens when the film guide release pin is pressed and closes when the shutter release button is pressed.

**2** The film holder and the pressure plate open when their respective release knobs are lifted up.

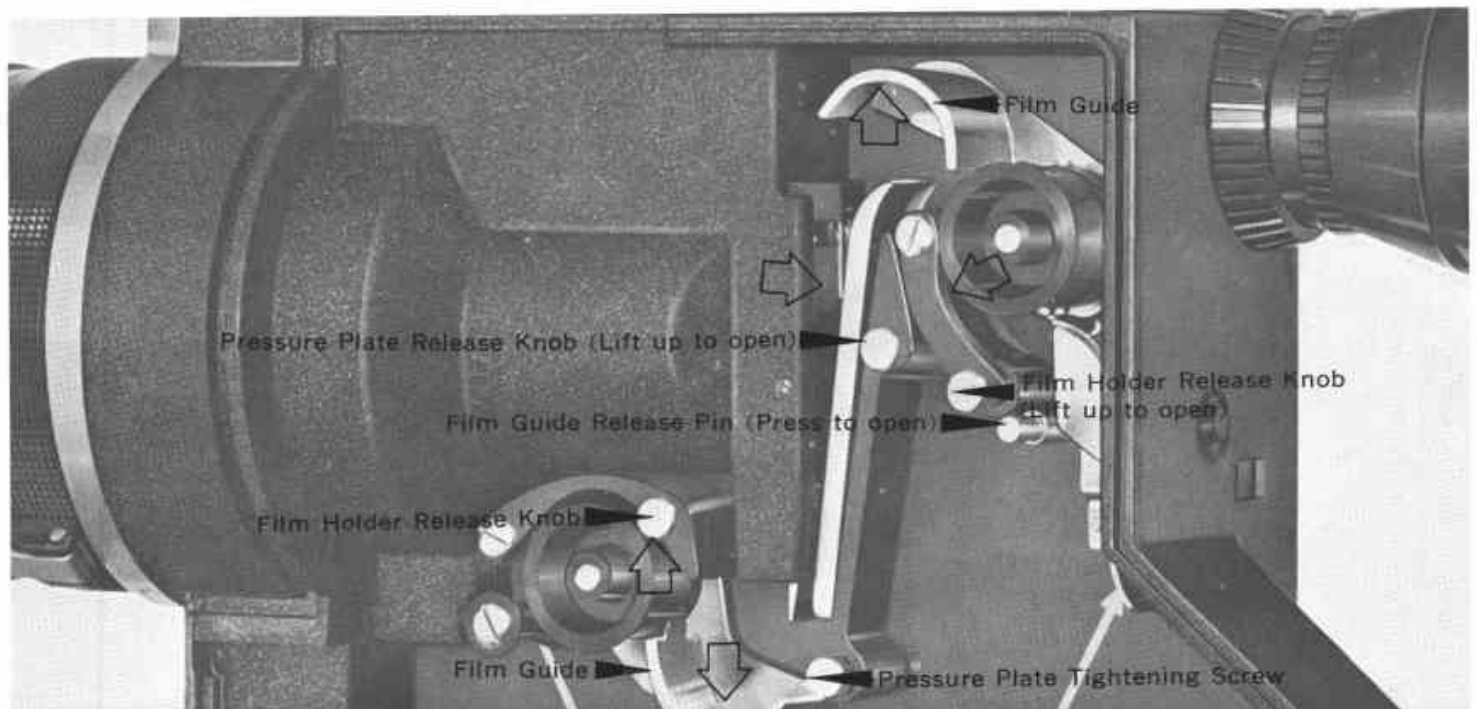



## How to Unload Film

### Footage Counter

As shooting proceeds, the footage counter indicates the length of exposed film in feet. The footage counter has graduations for every five feet, starting from "0", and figures are inscribed for every 20 feet. The "S" to "0" and "100" to "F" portions are both lengths for leaders. The footage counter automatically resets to "S" when the side cover is opened.

After the footage counter reaches "100", continue feeding the film until "F" and then unload the film. Make certain that the film does not loosen and put it into the film container. Send the exposed film to an authorized developing laboratory.

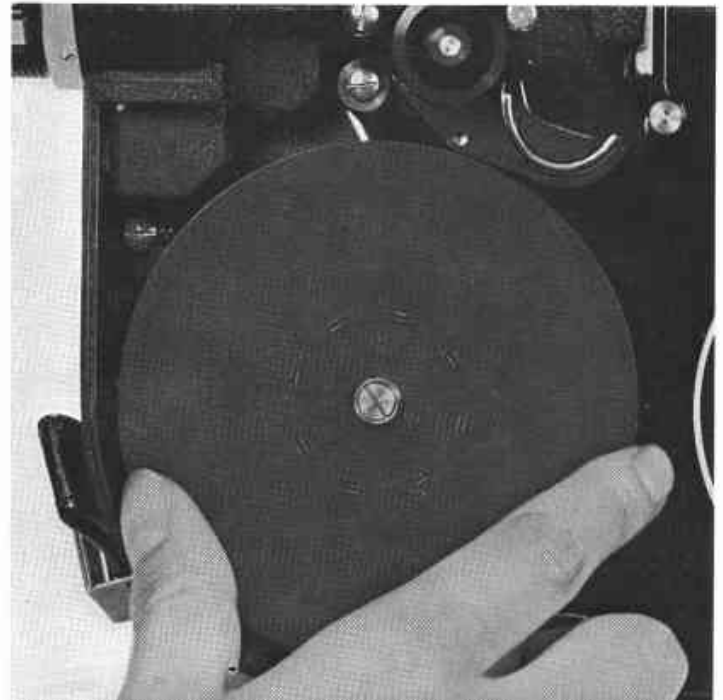

# Close-Up Lenses

The 72mm Close-Up Lenses 2100 and 1100 are available. 2100 and 1100 indicate the distances in millimeters from the tip of the lenses to the subject when the distance scales of the Close-Up Lenses are set at infinity.



## Canon Close-Up Lens 2100

Focal Length	13mm		38mm		76mm	
Distance Scale	∞	1.5m (5')	∞	1.5m (5')	∞	1.5m (5')
Film Plane-to-Subject Distance	2.3m (7'6-5/8")	0.98m (3'2-5/8")	2.3m (7'6-5/8")	0.98m (3'2-5/8")	2.3m (7'6-5/8")	0.98m (3'2-5/8")
Picture Area	1720 x 1230mm (5'7-3/4" x 4'1/2")	610 x 440mm (2' x 1'5-3/8")	550 x 410mm (1'9-5/8" x 1'4-1/8")	200 x 150mm (7-7/8" x 6")	280 x 200mm (11" x 7-7/8")	100 x 70mm (4" x 2-3/4")

## Canon Close-Up Lens 1100

Focal Length	13mm		38mm		76mm	
Distance Scale	∞	1.5m (5')	∞	1.5m (5')	∞	1.5m (5')
Film Plane-to-Subject Distance	1.3m (4'3-1/4")	0.77m (2'6-3/8")	1.3m (4'3-1/4")	0.77m (2'6-3/8")	1.3m (4'3-1/4")	0.77m (2'6-3/8")
Picture Area	900 x 640mm (2'11-1/2" x 2'1-1/4")	450 x 330mm (1'5-3/4" x 1'1")	290 x 210mm (11-3/8" x 8-1/4")	150 x 110mm (6" x 4-3/8")	150 x 110mm (6" x 4-3/8")	80 x 50mm (3-1/8" x 2")

## Canon Close-Up Lens 2100 + 1100

Focal Length	13mm		38mm		76mm	
Distance Scale	∞	1.5m (5')	∞	1.5m (5')	∞	1.5m (5')
Film Plane-to-Subject Distance	0.91m (3')	0.56m (1'10")	0.91m (3')	0.56m (1'10")	0.91m (3')	0.56m (1'10")
Picture Area	589 x 421mm (1'11-1/4" x 1'4-5/8")	351 x 258mm (1'2-1/8" x 10-1/8")	192 x 141mm (7-1/2" x 5-1/2")	119 x 86mm (4-3/4" x 3-3/8")	96 x 70mm (3-3/4" x 2-3/4")	59 x 42mm (2-3/8" x 1-5/8")

## How to Use the External Battery Box

When the separately available External Battery Box is used, approximately 16 reels, or double the number of reels can be shot at normal temperatures than when using the single battery loaded in the camera. This is because it is composed of two 12v nickel cadmium batteries in parallel. The performance of the batteries drop at temperatures of approximately 0°C (32°F) or under. Stabilized photography is possible, however, if the External Battery Box is kept warm by the body temperature of the user.

- 1** Remove the battery loaded in the camera when using the External Battery Box.
- 2** Plug the cord of the External Battery Box into the external battery box socket on the back side of the camera.
- 3** The power level for the external batteries are checked with the battery tester in the same manner as when checking the battery inside the camera.  
♦ Be sure to charge the two batteries simultaneously with the Scoopic Battery Charger-S.

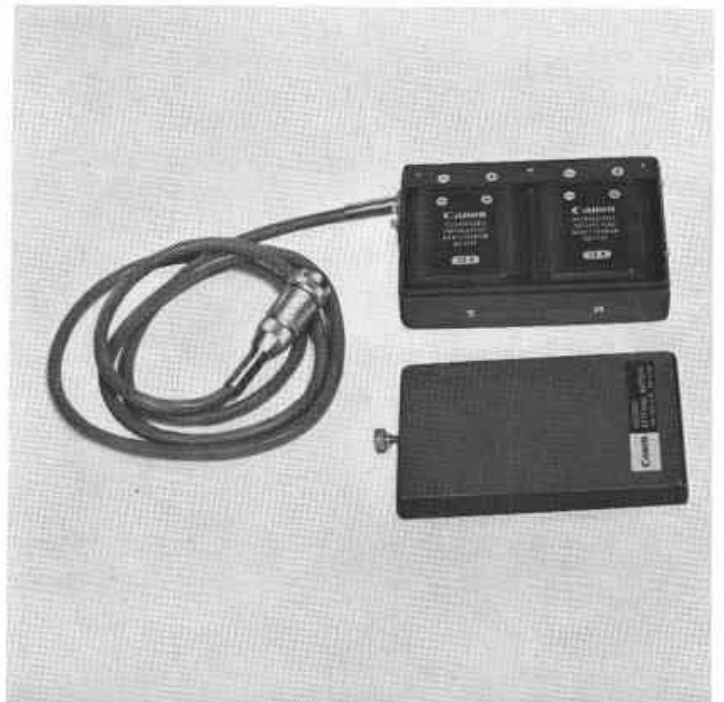

➤ The External Battery Box has a hook so that it can be conveniently hooked onto a waist belt.



## Tape Recorder Starting Socket

The tape recorder starting socket is coupled to the shutter release button. If the remote control cord of a portable battery-powered tape recorder is connected to this socket, the tape recorder starts recording simultaneously with the shooting of the camera for recording the sounds of the surrounding to add more realism to the movie. Acceptable tape recorder : 24 v 0.3A max.



## Cleaning the Aperture Section

It is important that the aperture section always be kept clean. The aperture section (the section where the film is held by the pressure plate), through which the film passes, is liable to accumulate dust or grit from the film. If left alone, these will scratch or soil subsequent reels of film. The aperture section can be kept sufficiently clean with a brush. It is best to clean this section whenever new film is loaded. Do not use anything hard, such as a metal brush.

Your Camera Body Number \_\_\_\_\_  
Date of Purchase \_\_\_\_\_  
Dealer's Name \_\_\_\_\_

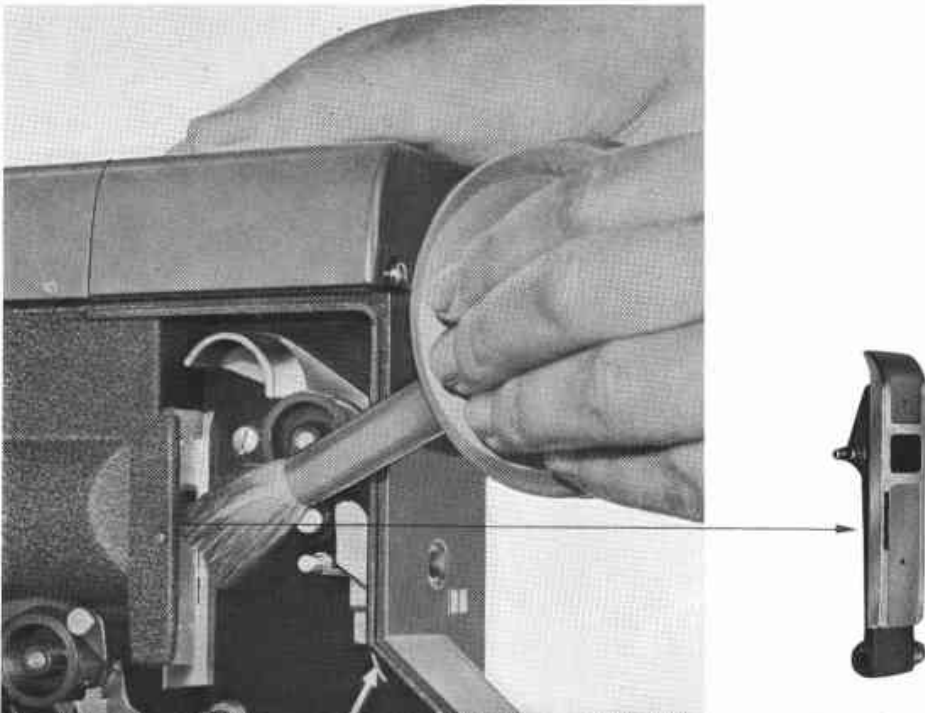

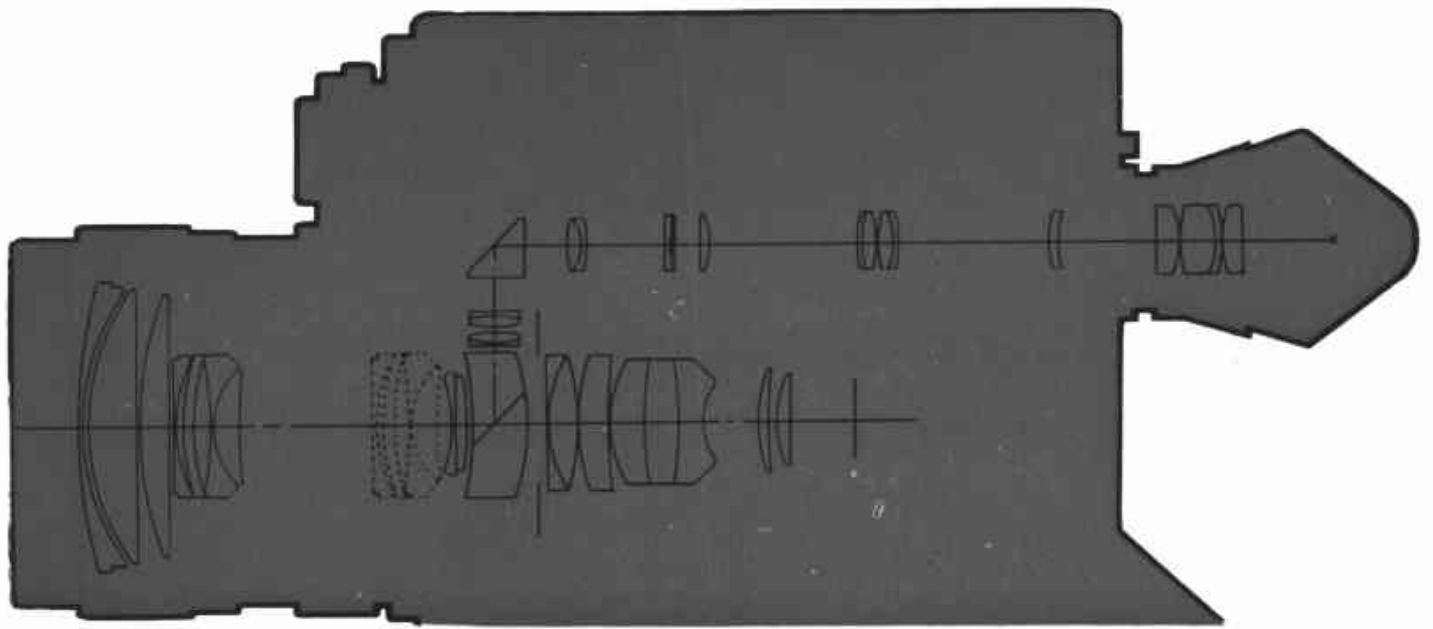
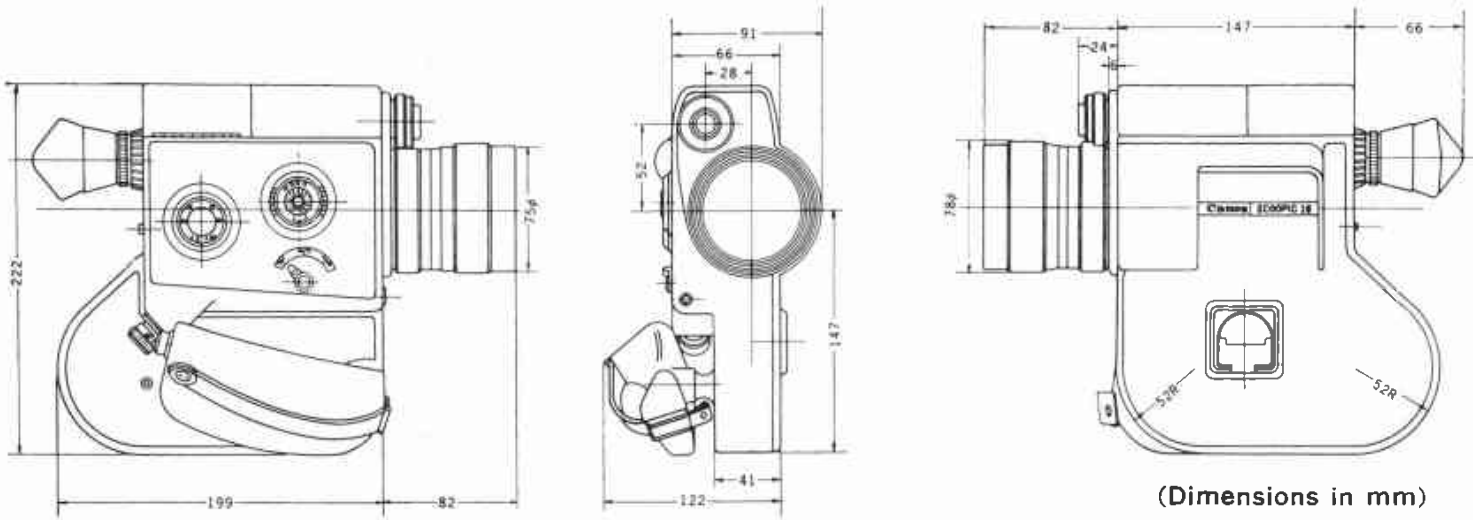



# Case

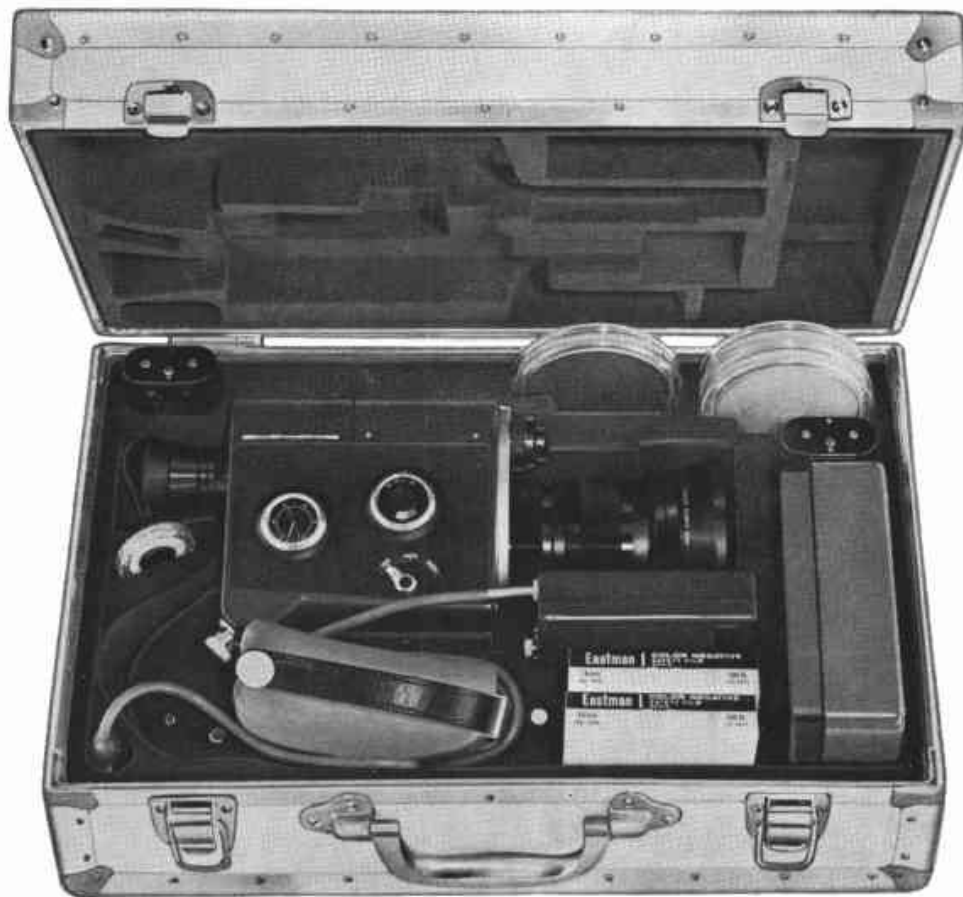





**CANON INC.**

9-9, Ginza 5-chome, Chuo-ku, Tokyo 104, Japan

**CANON U.S.A., INC.**

64-10 Queens Blvd., Woodside, New York 11377, U.S.A.

**CANON OPTICS & BUSINESS MACHINES CO., INC.**

636 South Serrano Ave., Los Angeles, California 90005, U.S.A.

**CANON AMSTERDAM N.V.**

Gebouw 70, Schiphol Oost, Holland

**CANON LATIN AMERICA, INC.**

Apartado 7022, Panama 5, Panama

PUB. NO. 5281E

1169B2

PRINTED IN JAPAN